

INITIAL USE: ~~4660~~ 4764

LOCATION:

ORIGINAL APPROVALS

HANDWRITTEN:	TYPED:	DATE:
DRAWN BY: <i>David Mock</i>	D. MOCK	02/14/2003
OTHER: <i>David Mock</i>	D. MOCK	11/25/2003
OTHER: <i>Jerry Olguin</i>	L. OLGUIN	11/25/2003
APPROVED: <i>K. OLIAT</i>	K. OLIAT	11/25/2003

CHANGES

REVISION	C.O. NO.	DATE	CHANGED BY	CHECKED BY
+A	PD	09/17/2003		
AA	M04292	11/25/2003		

TITLE: RBLT PT.:

P/N:

REVISION	C.O. NO.	DATE	CHANGED BY	CHECKED BY

SEE SITE-SANCTIONED DOCUMENT CONTROL SYSTEM FOR GENERAL PURPOSE STANDARD OPERATING PROCEDURES.

UNLESS OTHERWISE SPECIFIED:

DIMENSIONS ARE IN INCHES

.X ±.050
.XX ±.020
.XXX ±.005

TOLERANCES

ANGULAR ±0° 30'

MACH. SURF. 125√

MACH. SURF.

OTHER SURF.

FLAT WITHIN .001 IN./IN.

FLAT WITHIN .005 IN./IN.

DO NOT SCALE DRAWING

THREADS: CLASS 2A OR 2B
REMOVE BURRS & SHARP EDGES .020 MAX.

CONCENTRICITY MACH. SURFACE

T.I.R. WITHIN 1/2 SUM OF DIAS. TOLS., .001 MIN.

THIS DOCUMENT CONTAINS PROPRIETARY INFORMATION OF BECKMAN COULTER, INC. AND IS TENDERED SUBJECT TO THE CONDITIONS THAT THE INFORMATION (A) BE RETAINED IN CONFIDENCE (B) NOT BE REPRODUCED OR COPIED IN WHOLE OR IN PART AND (C) NOT BE USED OR INCORPORATED IN ANY PRODUCT, EXCEPT UNDER AN EXPRESS WRITTEN AGREEMENT WITH BECKMAN COULTER, INC.

Cable Assembly to include the following specifications:

Outer Diameter: 0.187 inches nominal

Number of conductors: Seven (7)

Shielding requirements: Double shielded - foil and spiral wrap

Construction of the cable consists of the following:

CORE: 1 strand of Uncoated Nylon Cord

1st LAY: 7 conductors, 28 AWG, UL 1731 rating for 105°C and 300v
Colors: Black, Brown, Red, Orange, Green, Blue, Violet

1st TAPE: Aluminum Mylar (Aluminum Out), 0.0015" thickness, 0.5" width, 50% Lap.
Bundle diameter under tape is approximately 0.103 inches
Bundle diameter over tape is approximately 0.109 inches

SHIELD: Spiral Tinned Copper Braid 36 AWG, 16 carrier (load 8 on bottom), 8 ends,
13.2 picks/inch, 90% coverage, 35 degree.
Copper weight: 6.0 lb / 1000 ft
Spiral inside diameter is approximately 0.109 inches
Spiral outside diameter is approximately 0.119 inches

2nd TAPE: Paper (Manning 210) 0.001" x 0.5" width, 35% Overlap.
Bundle diameter over tape is approximately 0.123 inches

JACKET: Grey PVC UL 2464 style, wall thickness 0.032 inches nominal

Preferred Vendor:

National Wire & Cable Corporation
136 San Fernando Road
Los Angeles, CA 90031-0307 USA
PN S10-7271

SEE SITE-SANCTIONED DOCUMENT CONTROL SYSTEM FOR GENERAL PURPOSE OPERATING PROCEDURES.

THIS DOCUMENT CONTAINS PROPRIETARY INFORMATION OF BECKMAN COULTER, INC. AND IS TENDERED SUBJECT TO THE CONDITIONS THAT THE INFORMATION (A) BE RETAINED IN CONFIDENCE, (B) NOT BE REPRODUCED OR COPIED IN WHOLE OR IN PART AND (C) NOT BE USED OR INCORPORATED IN ANY PRODUCT, EXCEPT UNDER AN EXPRESS WRITTEN AGREEMENT WITH BECKMAN COULTER, INC.

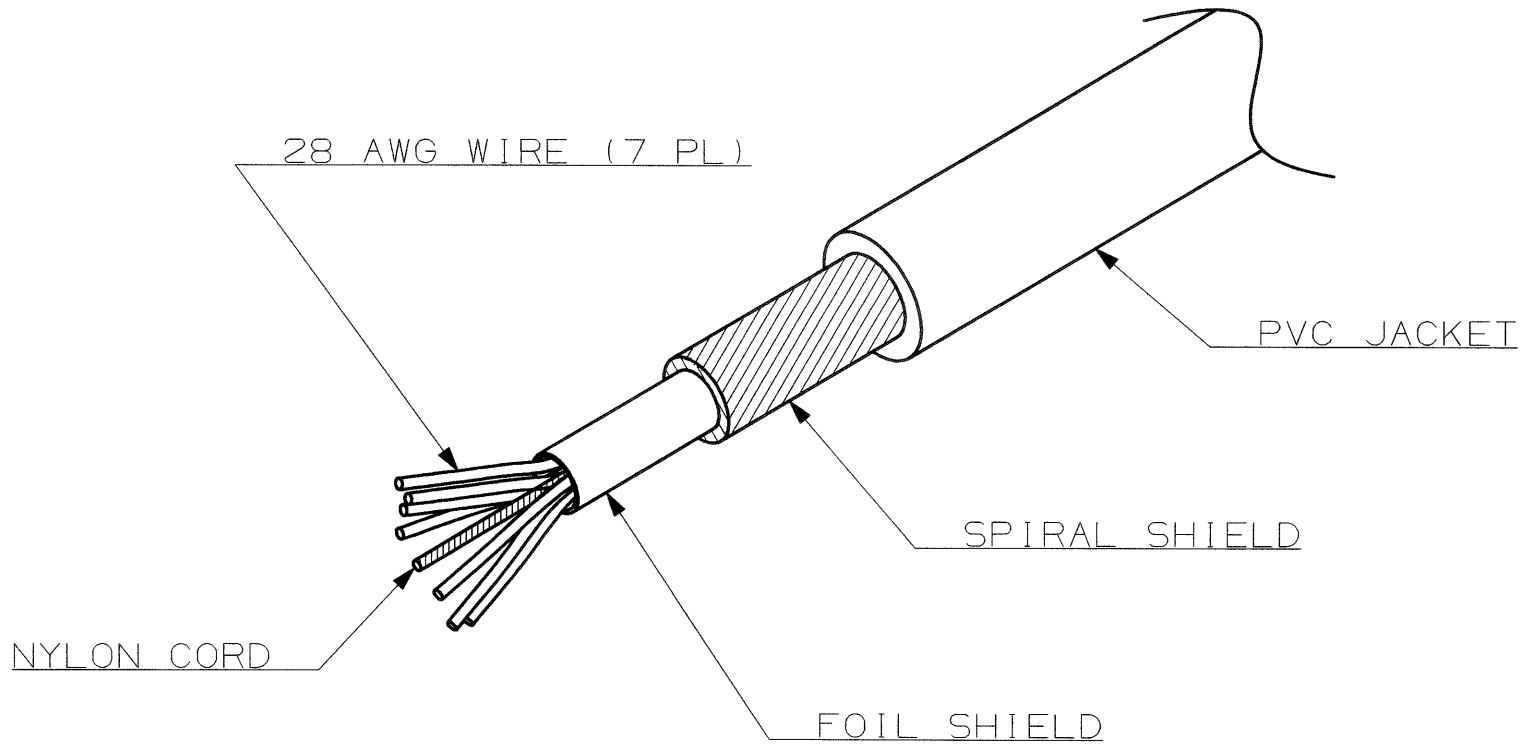

NOTES: UNLESS OTHERWISE SPECIFIED

A
SIZE
A08316

A SIZE	CODE IDENT NO.	DWG. NO. A08316	UG-CAD	REV AA
SCALE	INIT USE 4764	SHEET 3 OF 3		