

SPECIFICATION CONTROL DRAWING

THIS DRAWING CONTAINS INFORMATION PROPRIETARY TO RF INDUSTRIES, LTD. ANY UNAUTHORIZED USE OF THIS DRAWING IS EXPRESSLY PROHIBITED. ANY VIOLATION IS PUNISHABLE UNDER U.S. COPYRIGHT LAWS.

REV	DESCRIPTION	DWN	DATE	APPROVED
A	ENGINEERING RELEASE	KMM	6/4/96	R. RICE
B	CHG BODY THREADS TO METRIC / CHG OD OF #10 & #8	KMM	8/12/96	R. RICE
C	INCREASE CLAMP, WASHER & BACK NUT ID	CZS	6/24/99	R. RICE

ALL DIMENSIONS ARE REFERENCE ONLY

000000

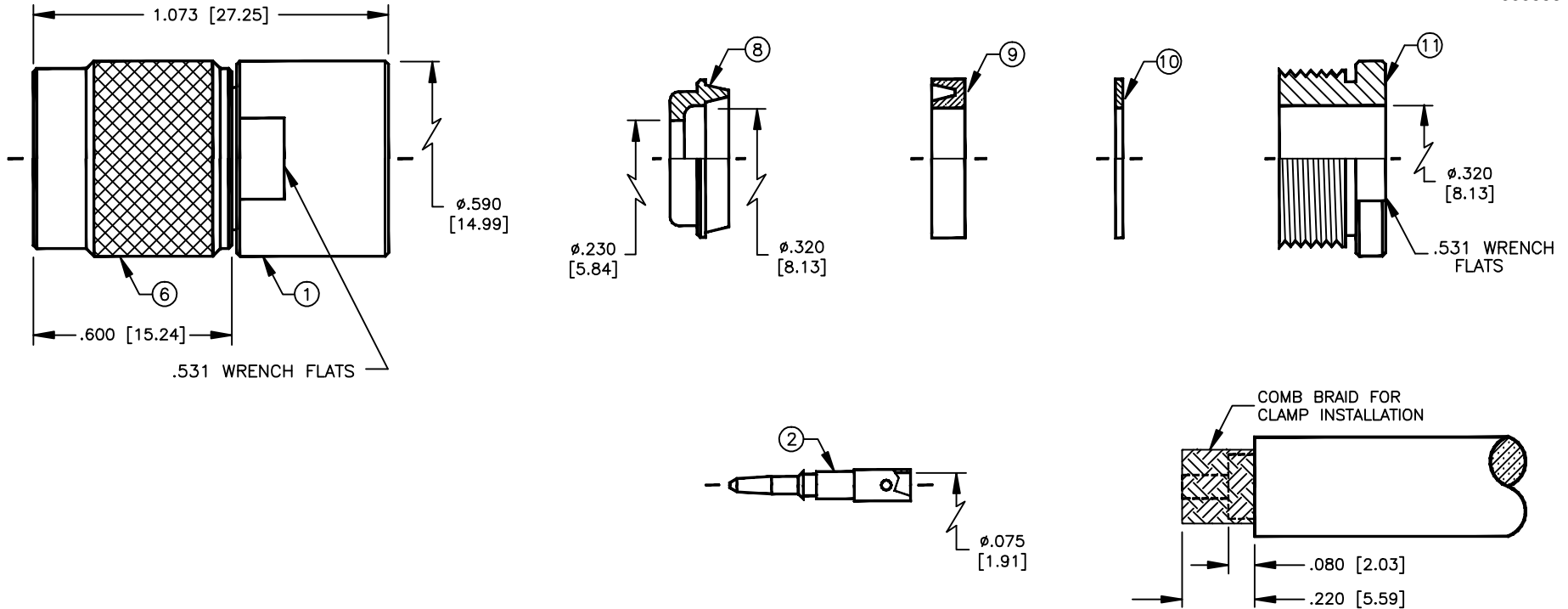

SUGGESTED STRIPPING INSTRUCTIONS

PIN TO BE SOLDERED

SPECIFICATIONS:

IMPEDANCE: 50 OHMS

ITEM	DESCRIPTION	QTY	MATERIAL	FINISH
11	BACK NUT	1	BRASS	NICKEL
10	WASHER	1	BRASS	NICKEL
9	GASKET	1	S.I. RUBBER	RED
8	CLAMP	1	BRASS	NICKEL
7	PRESS FIT WASHER	1	BRASS	NICKEL
6	SHELL	1	BRASS	NICKEL
5	RETAINING RING	1	BRASS	NONE
4	GASKET	1	S.I. RUBBER	RED
3	DIELECTRIC	1	PTFE	NONE
2	PIN	1	BRASS	GOLD
1	BODY	1	BRASS	NICKEL

DIMENSIONS ARE IN INCHES AND [MILLIMETERS]

UNLESS OTHERWISE NOTED TOLERANCES ARE:
DECIMALS DIAMETER

DRAWN
C. ZUNIGA 6/24/99

CHECKED

ORJ DRAWN
K. MAXWELL 4/19/96

APPROVALS DATE

RFconnectors
DIVISION OF RF INDUSTRIES, LTD.

7610 MIRAMAR RD
SAN DIEGO, CA 92126
(858) 549-6340
(858) 549-6345 FAX

RFT-1201-03

TNC MALE CLAMP FOR FUJUKURA 5D-FB CABLE

SIZE	CABLE GROUP	DWG NO.	REV
A	N/A	8634	C

SCALE: 2:1 CAD FILE 13ARC B SHEET 1 OF 1