

NOTES: UNLESS OTHERWISE SPECIFIED

1. INTERFACE COMPLIANT TO SMPTE 304 SPECIFICATION.
2. MATERIAL SPECIFICATIONS:
 CONTACTS AND TRI-LOC BODY: COPPER ALLOY
 ALIGNMENT PINS: BRASS PER ASTM B16
 CRIMP SLEEVE: PHOS. BRONZE
 O-RINGS AND STRAIN RELIEF: SILICONE RUBBER
 ALL PLASTIC PARTS: 20% GLASS FILLED POLYPROPYLENE
 ALL OTHER METAL PARTS: 303 STAINLESS STEEL PER ASTM A582
3. FINISH SPECIFICATIONS:
 STAINLESS STEEL PARTS: PASSIVATE
 TRI-LOC BODY: .000100 MIN NICKEL PER AMS-QQ-N-290
 OVER COPPER FLASH PER ASTM B734 (RoHS)
 CONTACTS: .000100 MIN GOLD PER ASTM B488 OVER
 .000080 MIN NICKEL PER AMS-QQN-290 (RoHS)
 CRIMP SLEEVE: .000100 MIN NICKEL PER AMS-QQ-N-290 OVER
 COPPER FLASH PER ASTM B734 (RoHS)
4. ELECTRICAL SPECIFICATIONS:
 LOW VOLTAGE CONTACTS: 42 - 60 VAC, 1 AMP
 AUX ELECTRICAL CONTACTS: 600 VAC, 10 AMP
5. ENVIRONMENTAL:
 OPERATING TEMPERATURE RATING: -40°C TO 75°C
 NON-OPERATING/STORAGE TEMPERATURE RATING: -40°C TO 85°C
 HUMIDITY: <95 RH (AT 40°C)

6. OPTICAL:
 WAVELENGTH: 1100nm - 1350nm
 INSERTION LOSS: 0.3dB TYPICAL, 0.5dB MAX
 RETURN LOSS: > -45dB, -50dB TYPICAL
7. REPLACEMENT KITS:
 CONTACT KIT: 7760-000-00701Z
 CONTACT KIT WITH CARTRIDGE: 7760-000-00703Z
8. CABLE PREPARATION AND STRIPPING PROCEDURE: CAP-E05.
9. OPTIONAL ENVIRONMENTAL BOOT 7760-000-00704Z SOLD SEPARATELY.
10. RED LDPE DUST CAP INCLUDED (NOT SHOWN)
11. CRIMP TOOLING:
 FOR FACTORY APPLICATION USE HAND TOOL KTH-1000 AND DIE KTH-2035
 FOR FIELD APPLICATION USE HAND TOOL KTH-5000 AND DIE KTH-5018

REV	DESCRIPTION	BY DATE	APPD
E	REVISED PER ER27962	JCF 01/06/11	XXX

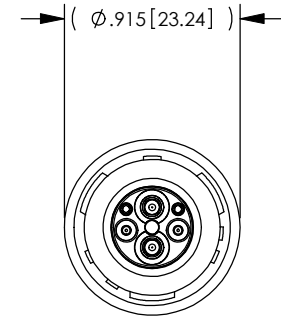
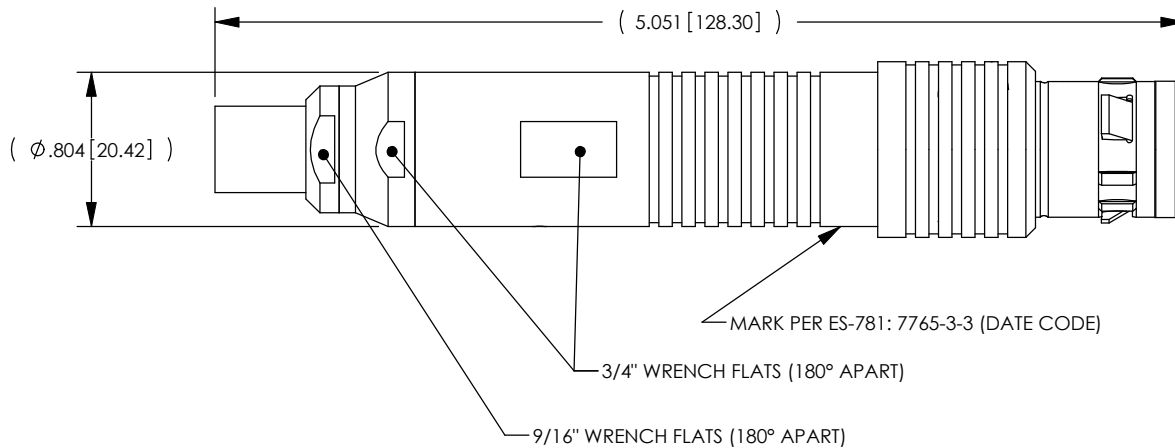
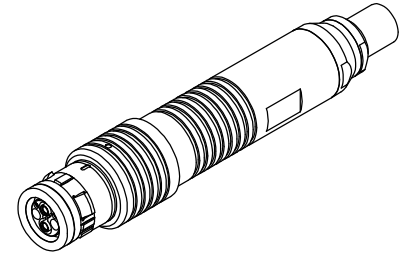

CATALOG P/N: 7765-3-3

PER ASME Y14.5M-1994 UNLESS OTHERWISE SPECIFIED: DIMENSIONS ARE IN INCHES [MM] TOLERANCES: DECIMAL: .XX [X.X] ± .01 [0.3] .XXX [X.XX] ± .005 [0.13] .XXXX [X.XXX] ± .XXXX ANGLES: ± 2° SCALE: 1:1				by WINCHESTER ELECTRONICS		Winchester Electronics Corporation 62 Barnes Industrial Road North Wallingford, Connecticut 06492		
CUSTOMER SALES DRAWING				THIRD ANGLE		TRI-LOC, SMPTE 304, PLUG		
DRAWN	DATE	APPROVED	DATE	A	SD7765-3-3	SHT	OF	REV
PSM	03/25/09	RL	08/03/09					
APPROVED	DATE	APPROVED	DATE					
WPM	08/03/09	JCF	01/19/10					E

REPLACEMENT COMPONENT ORDERING NUMBERS

REV	DESCRIPTION	BY DATE	APPD
E	REVISED PER ER30231	JCF 01/06/11	XXX

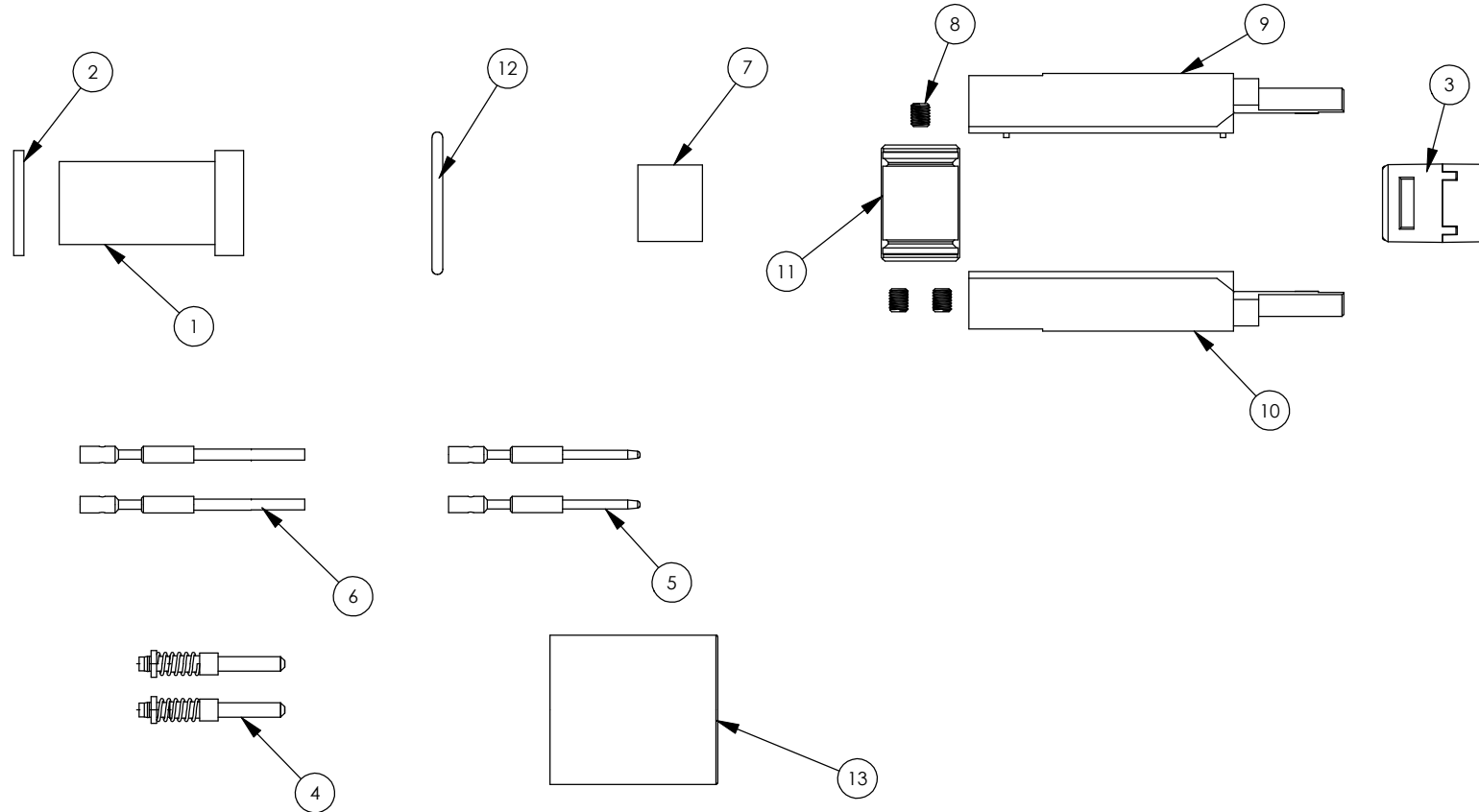

13	VNSC-3-4U	RED LDPE DUST CAP, .750" ID	25
12	78-0705U	REAR O-RING	25
11	78-1012U	STRENGTH MEMBER SUPPORT CLAMP	10
10	78-3013U	PLUG INSULATOR HALF SIDE "A"	25
9	78-3012U	PLUG INSULATOR HALF SIDE "B"	25
8	78-0102U	#4-40 HEX SET SCREW	10
7	1-8156U	CRIMP SLEEVE (CABLE SHIELD FERRULE)	25
6	78-4006U	PLUG FEMALE CRIMP CONTACT	50
5	78-4005U	PLUG MALE CRIMP CONTACT	50
4	78-7016U	TERMINI FOR MANUAL POLISH W/ PROT. CAP	10
3	78-7003U	PLUG CARTRIDGE ASSEMBLY	10
2	78-0301U	WASHER FOR REAR CABLE SEAL	25
1	78-0701U	REAR CABLE SEAL	25
ITEM NO.	PART NO.	Description	QTY.

PLATING CODE(S)

CATALOG P/N: 7765-3-3

<small>PER ASME Y14.5M-1994 UNLESS OTHERWISE SPECIFIED: DIMENSIONS ARE IN INCHES [MM] TOLERANCES: DECIMAL: .XX [X.X] ± .01 [0.3] .XXX [X.XX] ± .005 [0.13] .XXXX [X.XXX] ± .XXXX ANGLES: ± 2° SCALE: 1:1</small>		 by WINCHESTER ELECTRONICS Winchester Electronics Corporation 62 Barnes Industrial Road North Wallingford, Connecticut 06492	
CUSTOMER SALES DRAWING		THIRD ANGLE	
TRI-LOC, SMPTE 304, PLUG		SD7765-3-3	
DRAWN PSM	DATE 03/25/09	APPROVED RL	DATE 08/03/09
APPROVED WPM	DATE 08/03/09	APPROVED JCF	DATE 01/19/10
A		SHT 2	OF 2
		REV E	