

REVISION HISTORY				
ZONE	REV	DESCRIPTION	DATE	BY
ALL	X1	UNRELEASED DRAWING	MCL	12/23/16

26 AWG, SINGLE, HIGH TENSILE  
COPPER CONDUCTOR, 0.010" SILICONE  
RUBBER, WHITE

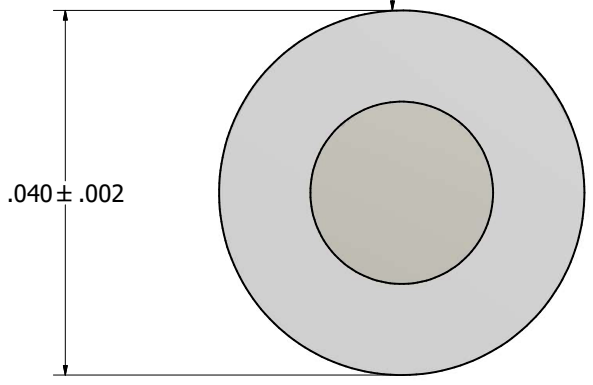

VIEW 1  
95:1

**UNRELEASED DRAWING**

NOTES: (UNLESS OTHERWISE SPECIFIED)  
1. NA

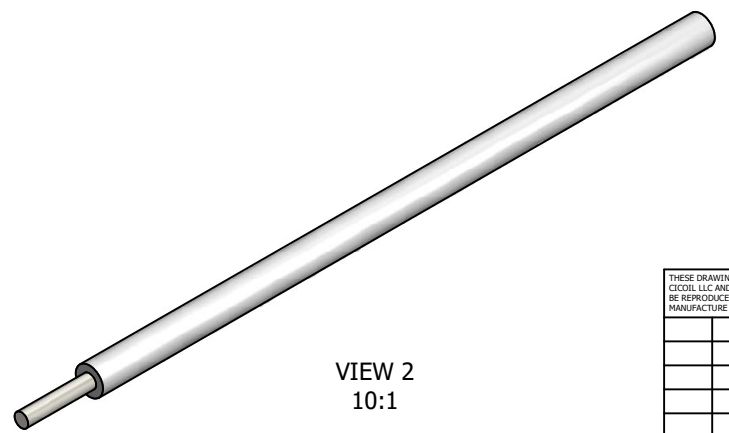

VIEW 2  
10:1

<small>THESE DRAWINGS AND SPECIFICATIONS ARE THE PROPERTY OF CICCOIL LLC AND ARE ISSUED IN STRICT CONFIDENCE AND SHALL NOT BE REPRODUCED OR COPIED OR USED AS THE BASIS FOR THE MANUFACTURE OR SALE OF EQUIPMENT WITHOUT PERMISSION.</small>						VIEW PROJECTION		 <small>24960 AVENUE TIBBITTS, VALENCIA, CA 91355 www.ciccoil.com 661-295-1295</small>		
				STANDARD TOLERANCES UNLESS OTHERWISE NOTED		SIGNATURE				
DIMENSIONS ARE IN INCHES		DRAWN: EAS		12/23/2016		TITLE				
.X+/-		CHECK: EAS		12/23/2016		HIGH FLEX GROUNDING CABLE				
.XX+/-		ENGINEER: EAS		12/23/2016		CAGE CODE				
.XXX+/-		CUSTOMER:				SIZE				
ANGLES +/-						DRAWING NUMBER/PART NUMBER				
[MM]						19476				
MATERIAL:						REVISION				
APPLICATION						X1				
DO NOT SCALE DRAWING						SCALE				
						FILE: 136W100NC_UNRELEASED.dwg				

4

3

2

1

D

D

C

C

B

B

B

B

A

A

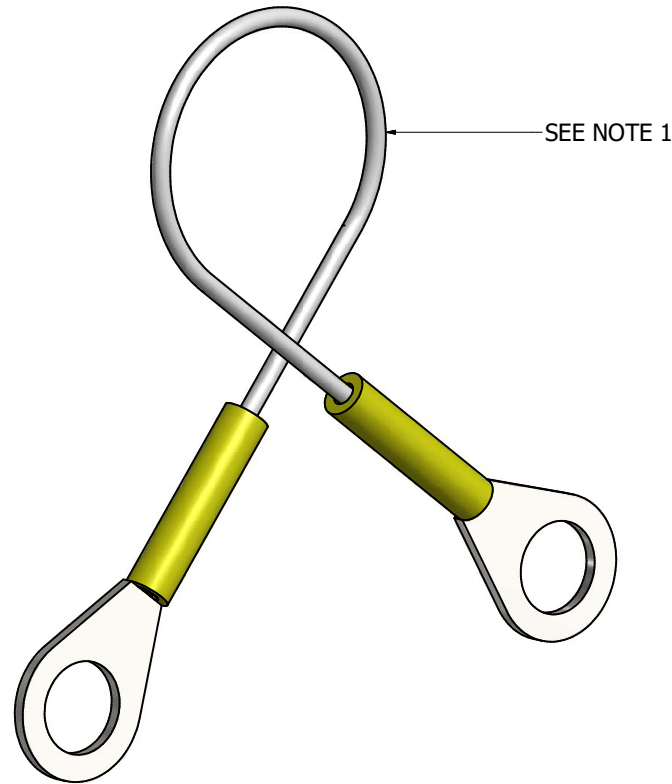

VIEW 3  
5:1

**UNRELEASED DRAWING**

1. FOR RECOMMENDATION: TO ATTAIN MAX. FLEX LIFE, CABLE TO BE CONFIGURED AS SHOWN. THIS ALLOWS FOR AN EVEN DISTRIBUTION OF STRESS ON THE CABLE DURING FLEXING.

<small>THESE DRAWINGS AND SPECIFICATIONS ARE THE PROPERTY OF CICOIL LLC AND ARE ISSUED IN STRICT CONFIDENCE AND SHALL NOT BE REPRODUCED OR COPIED OR USED AS THE BASIS FOR THE MANUFACTURE OR SALE OF EQUIPMENT WITHOUT PERMISSION.</small>				VIEW PROJECTION		<b>CICOIL</b> <sup>®</sup> <small>The Clear Choice</small> 24960 AVENUE TIBBITTS, VALENCIA, CA 91355 www.cicoil.com 661-295-1295			
				STANDARD TOLERANCES UNLESS OTHERWISE NOTED		SIGNATURE		DATE	
DIMENSIONS ARE IN INCHES				DRAWN: EAS		12/23/2016			
.X+/-				CHECK: EAS		12/23/2016			
.XX+/-				ENGINEER: EAS		12/23/2016			
.XXX+/-				CUSTOMER:					
ANGLES +/- [MM]				MATERIAL:					
DASH NO				QTY REQD		NEXT ASSEMBLY		FINAL ASSEMBLY	
APPLICATION				DO NOT SCALE DRAWING		SCALE		FILE: 136W100NC_UNRELEASED.dwg	
CAGE CODE		SIZE		DRAWING NUMBER/PART NUMBER		REVISION			
19476				136W102		X1			