

ESTIMATED CORD WEIGHT: 81lbs/1000'

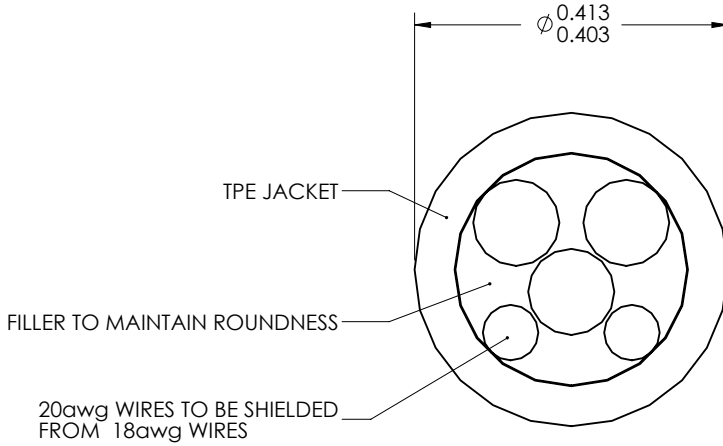
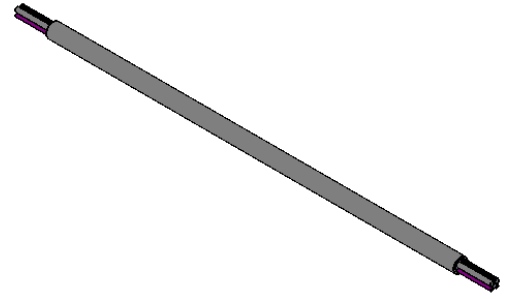

**SPECS:**

- Minimum 300V RMS
- Minimum 105C
- UL Listed / CSA Certified
- White TPE Jacket w/filler to maintain roundness
- 18awg - White - copper stranded
- 18awg - Black - copper stranded
- 18awg - Green - copper stranded
- 20awg - Purple(Violet)\* - copper stranded - shielded
- 20awg - Grey\* - copper stranded - shielded
- \*Purple and Grey to be shielded from White/Black/Green
- RoHS Compliant

**ORDER REQUIREMENTS:**

- To be supplied on 1000' spools
- Spool to have 1-3/4" center hole
- Spool to be wrapped to prevent damage or marring of outer jacket during transport
- Spool to be clearly marked with:
  - OCL part number
  - Vendor part number
  - Listing (UL/CSA) File number

PART NUMBER: 800-00072		UNLESS OTHERWISE SPECIFIED: DIMENSIONS ARE IN INCHES TOLERANCE VALUES		FILE NAME: 800-00072
PART DESCRIPTION: CORD 5-WIRE WHITE - LINE VOLTAGE - TPE		DIM ± .005		DESIGNED BY: JWB
REV. A	DESCRIPTION:	DATE: 16 JUN 17	REV BY: JWB	DATE: 16 JUN 17
-		16 JUN 17	JWB	FINISH: WHITE TPE
				MATERIAL: WIRE
SCALE IS FOR REFERENCE ONLY DO NOT SCALE DRAWING				SCALE: 4:1
The drawings and specifications and ideas, designs and arrangements represented on these drawings are and shall remain the property of The Original Cast Lighting (OCL) and no part thereof shall be copied, disclosed, to others or used in conjunction with any work or project other than the specified project for which they have been prepared and developed, without written consent of OCL. Visual contact with these plans or specifications shall constitute conclusive evidence of acceptance of these restrictions. The Original Cast Lighting - 11902 Lackland Road - St.Louis, Mo 63146 - ph 314-863-1895 - fx 314-863-3278 - www.OCL.com				DRAWING SIZE: A
				1 OF 1