

THIS DRAWING IS UNPUBLISHED. RELEASED FOR PUBLICATION
 © COPYRIGHT - By - ALL RIGHTS RESERVED.

LOC	DIST	REVISIONS					
G	14	P	LTR	DESCRIPTION	DATE	DWN	APVD
		G1		REVISED PER ECO-11-004587	11MAR11	RK	HMR

METRIC
 DIMENSIONS LISTED IN mm [INCHES]

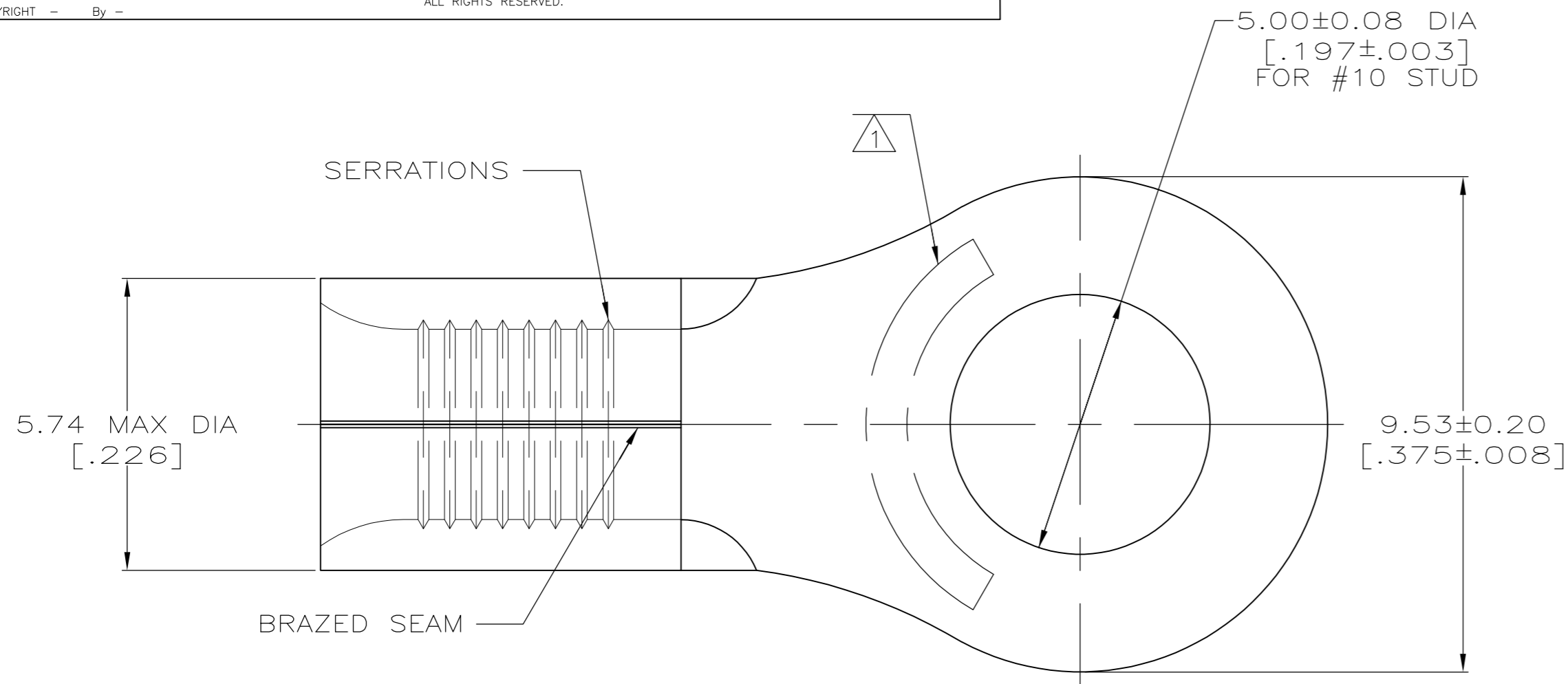

AMP WIRE RANGE	E13288 Listed
12-10 AWG SOLID OR STRANDED	12-10 AWG STRANDED
LR7189 Certified	MILITARY P/N AND CLASS
12-10 AWG SOLID OR STRANDED	MS20659-105 CLASS 1 & 2 P/N 33457 CLASS 2 P/N 2-33457-2

STAMP AMP 12-10* APPROX AS SHOWN

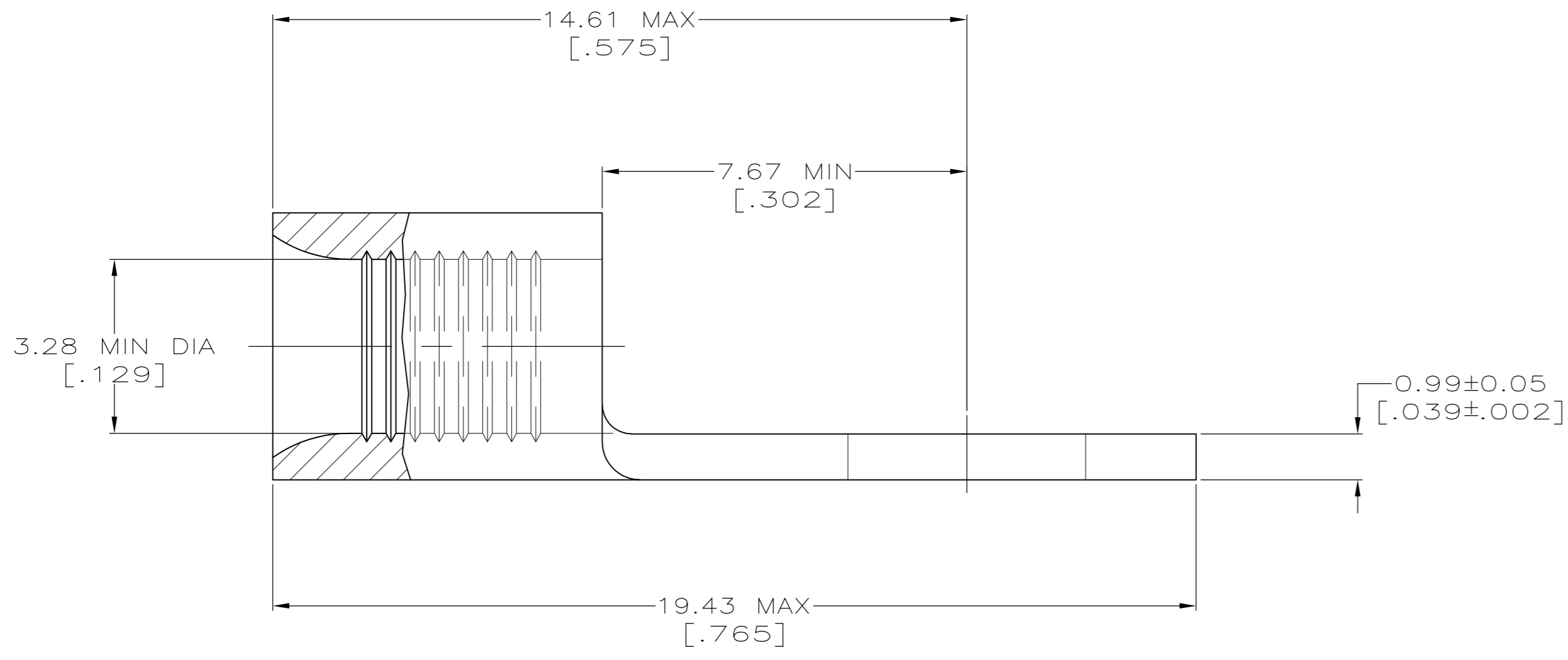

AMP INCORPORATED CUSTOMER SERVICE SYSTEMS		MAX RECOMMENDED OPERATING TEMPERATURE: 170° C MAX
FOR ADDITIONAL PRODUCT INFORMATION OR COPIES OF DRAWINGS AND TECHNICAL DOCUMENTS	PRODUCT INFORMATION CENTER 1-800-522-6752	VOLTAGE RATING: NOT APPLICABLE
FOR APPLICATION TOOLING INFORMATION	TOOLING ASSISTANCE CENTER 1-800-722-1111	WIRE CROSS SECTIONAL AREA RANGE: 2.62-6.64mm ² [5,180-13,100] CIR MILS SOLID OR STRANDED
FOR ORDER ENTRY	1-800-526-5142	THIS DRAWING IS A CONTROLLED DOCUMENT FOR AMP INCORPORATED. IT IS SUBJECT TO CHANGE AND THE CONTROLLING ENGINEERING ORGANIZATION SHOULD BE CONTACTED FOR THE LATEST REVISION.

25	LOOSE PIECE, BAG	8-33457-5
100	LOOSE PIECE, BOX	8-33457-1
2500	ON TAPE	2-33457-2
----	LOOSE PIECE	33457
QUANTITY	PACKAGING TYPE	PART NO

THIS DRAWING IS A CONTROLLED DOCUMENT.		DWN TA BRINKMAN 3-17-93	TE Connectivity	
DIMENSIONS: MM [INCHES]		CHK DA PATTERSON 3-17-93	NAME DE MILLER 3-17-93	
TOLERANCES UNLESS OTHERWISE SPECIFIED:		APVD DE MILLER 3-17-93	PRODUCT SPEC	
0 PLC ± -		APPLICATION SPEC		
1 PLC ± -		WEIGHT		
2 PLC ± -		SIZE A2		
3 PLC ± -		CAGE CODE 00779		
4 PLC ± -		DRAWING NO C=33457		
ANGLES ± -		RESTRICTED TO		
MATERIAL COPPER PER ASTM B-152 ANNEALED	FINISH TIN PLATE 0.0025±[0.00100] MIN THK PER MIL-T-10727	SCALE 10:1		
CUSTOMER DRAWING		SHEET 1 of 1		
		REV G1		