

Schematische Darstellung
(schematic view)

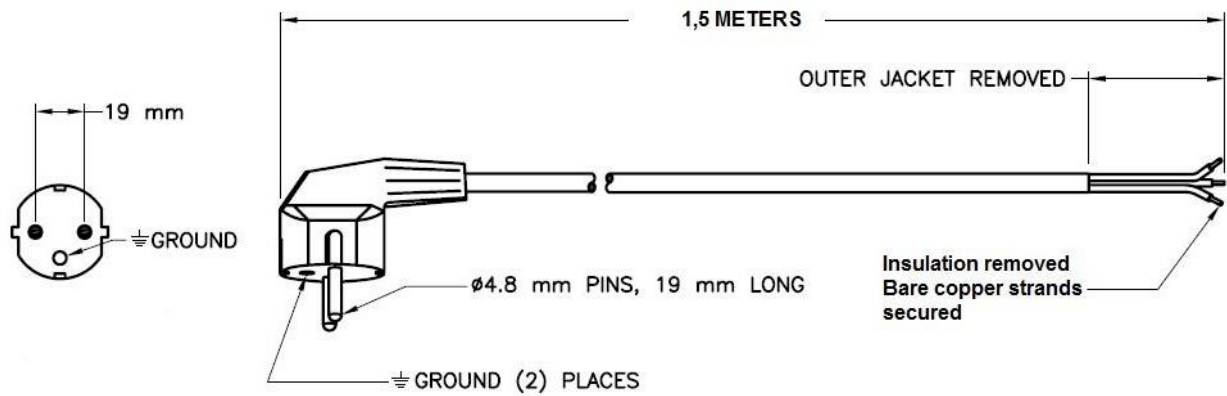

Spezifikation:

(specification)

Kabellänge: 1,5m

(cable length)

Kabeltyp: H05VV-F 3G0.75mm² schwarz (black)

(cable typ)

Anschluss Seite A: CEE 7/7 Schuko-Winkelstecker schwarz (plug, angled, black)

(Connector Type A)

Anschluss Seite B: 30mm abgemantelt (bared), 6mm Teilabzug (bare copper strands secured)

(Connector Type B)

Lieferform:

(delivery form)

einzel gewickelt (single wrapped)

THIS DOCUMENT

NOTICE TO PERSONS RECEIVING

CONFIDENTIAL AND PROPRIETARY

THIS DOCUMENT, INCLUDING THE DRAWING AND INFORMATION CONTAINED THEREON, IS CONFIDENTIAL AND IS THE EXCLUSIVE PROPERTY OF EATON GMBH. RECIPIENT ACKNOWLEDGES THAT IT IS TO BE USED ONLY FOR THE PURPOSES SPECIFIED IN THE ORDER AND IS NOT TO BE DISCLOSED TO OTHERS, COPIED OR OTHERWISE REPRODUCED WITHOUT THE PRIOR WRITTEN CONSENT OF EATON. IN THE CASE OF CONFLICTING CONTRACTUAL PROVISIONS, THIS NOTICE SHALL GOVERN THE STATUS OF THIS DOCUMENT. © 2010 Eaton - All Rights Reserved

| | | | | | |
|-------------------------------|--|---|----------|--|----------------|
| Änderung | | Eaton Industries (Austria) GmbH Eaton Electrical Sector A-3943 Schrems, Eugenia 1 TEL. 02853/702-0*, Fax 02853/76509 | | EATON <i>Powering Business Worldwide</i> | |
| | | Entworfen: | | | DOC |
| | | Gezeichnet: | 09.08.18 | GGD | FU 2023 |
| | | Geprüft: | | RDA | |
| Anschluss Kabel Schuko | | | | | |
| Funksystem | | | | Ersatz für: | |
| | | | | Ers. durch: | |
| | | | | FU2023.doc | |