

REVISION HISTORY			
REV	DESCRIPTION	DATE	APPROVED
01	RELOCATED CONDUIT MTG HOLES AND ADDED RECTANGLE CUTOUT. ADDED (4x) .562" HOLES FOR PLINTH BOLT DOWN REFERENCED FROM THE 543660 ROW CAB. CHANGES MADE TO RFM-723670-BM-TEMPLATE ON PAGE 6	2021-04-26	Voula
02	ADDING GROUND BAR 543660-GB TO FRONT RIGHT WALL. INCREASED HOLE 3.75 TO 4.75 ON MID DIVIDER.	09-Dec-21	JG
03	MODIFIED DOORS FOR ROLLER WHEEL ASSEMBLY, AND FRONT BATT DOOR FOR PLC GROUP FC UNIT. HEATER CABLE HOLE ADDED TO BATTERY BACK PANEL. RECEPTICLE MOVED UP TO 1.5 INCHES FROM TOP IN THE BATTERY COMPARTMENT. HEATER STRIP ADDED.	07-Oct-22	JG
04	CUTOUTS IN FRONT BATT DOOR MOVED UP 2". PLYWOOD PIECE ADDED FOR CORD FASTENING.	17-Oct-22	JG

TOP VIEW
(WITHOUT FAN HOOD)

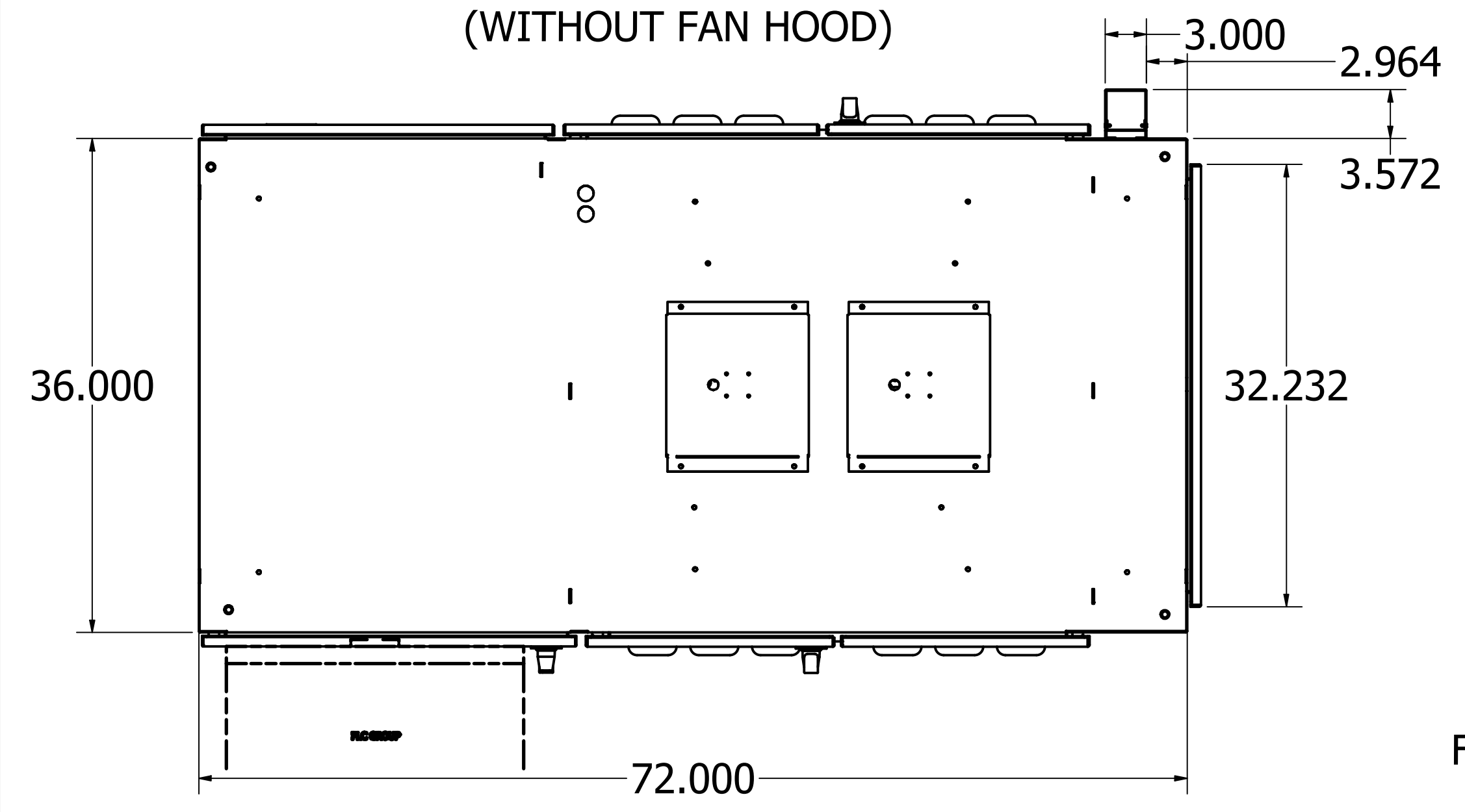

FOR ILLUSTRATION PURPOSES ONLY

FRONT VIEW
(WITH FANHOOD & PLINTH)

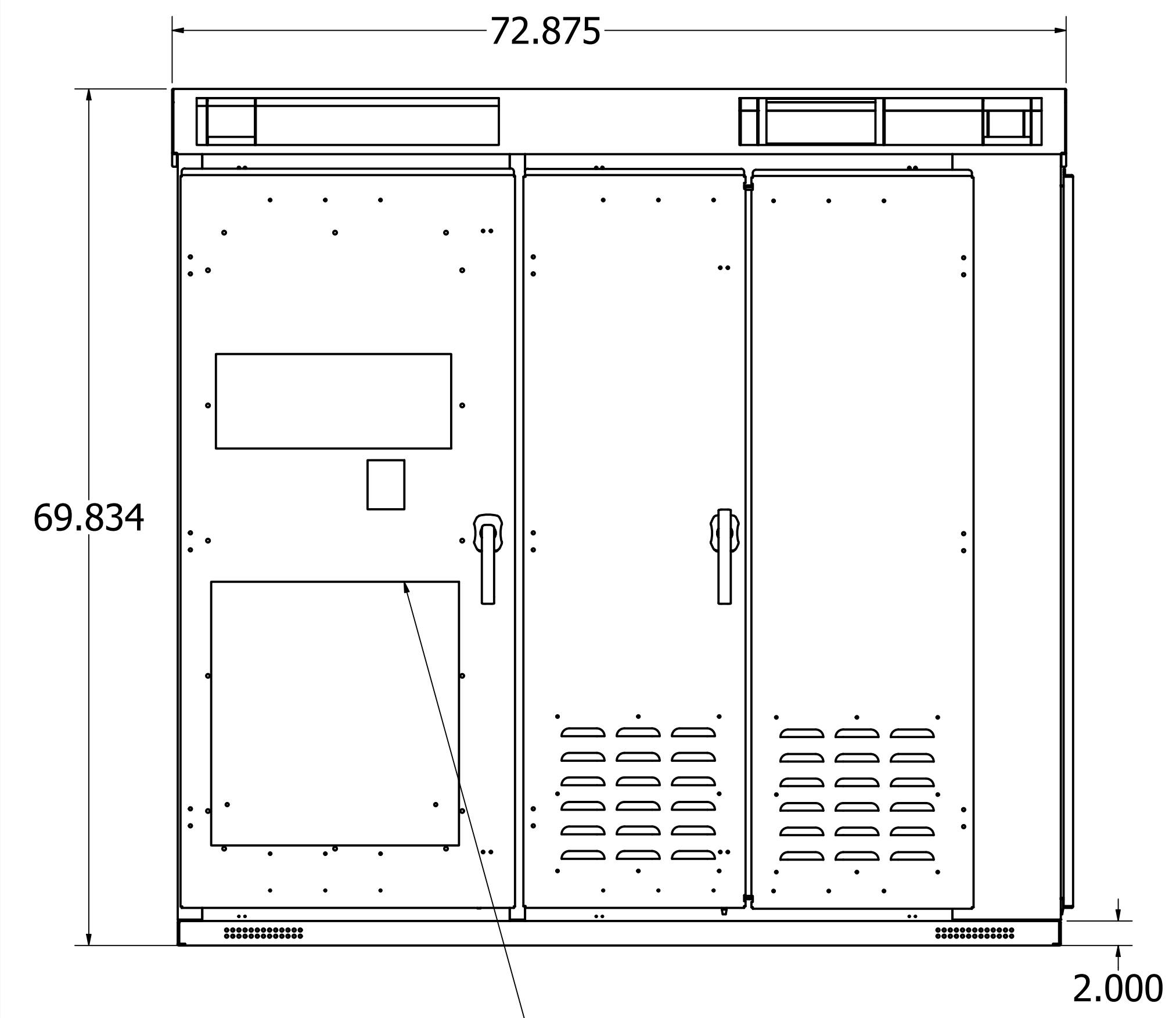

CUTOUTS FOR PLC GROUP FC UNIT WITH CLEARANCE HOLES FOR MOUNTING

SIDE VIEW

(WITHOUT FANHOOD, PLINTH, POWER DIVIDER AND POWER SUPPLY DOOR)

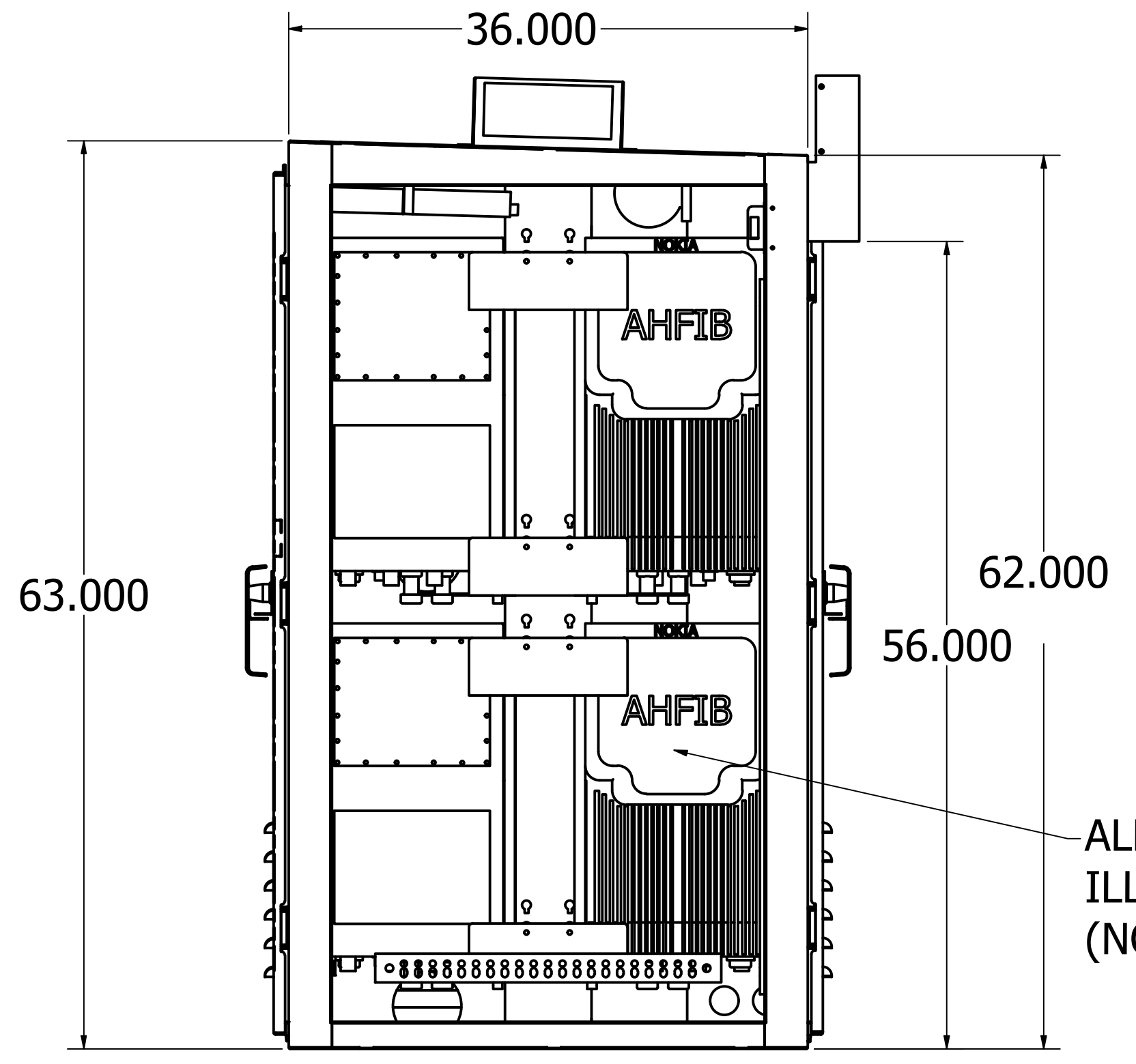

ALL RADIOS, AND RADBRKTS FOR ILLUSTRATION PURPOSES ONLY (NOT INCLUDED)

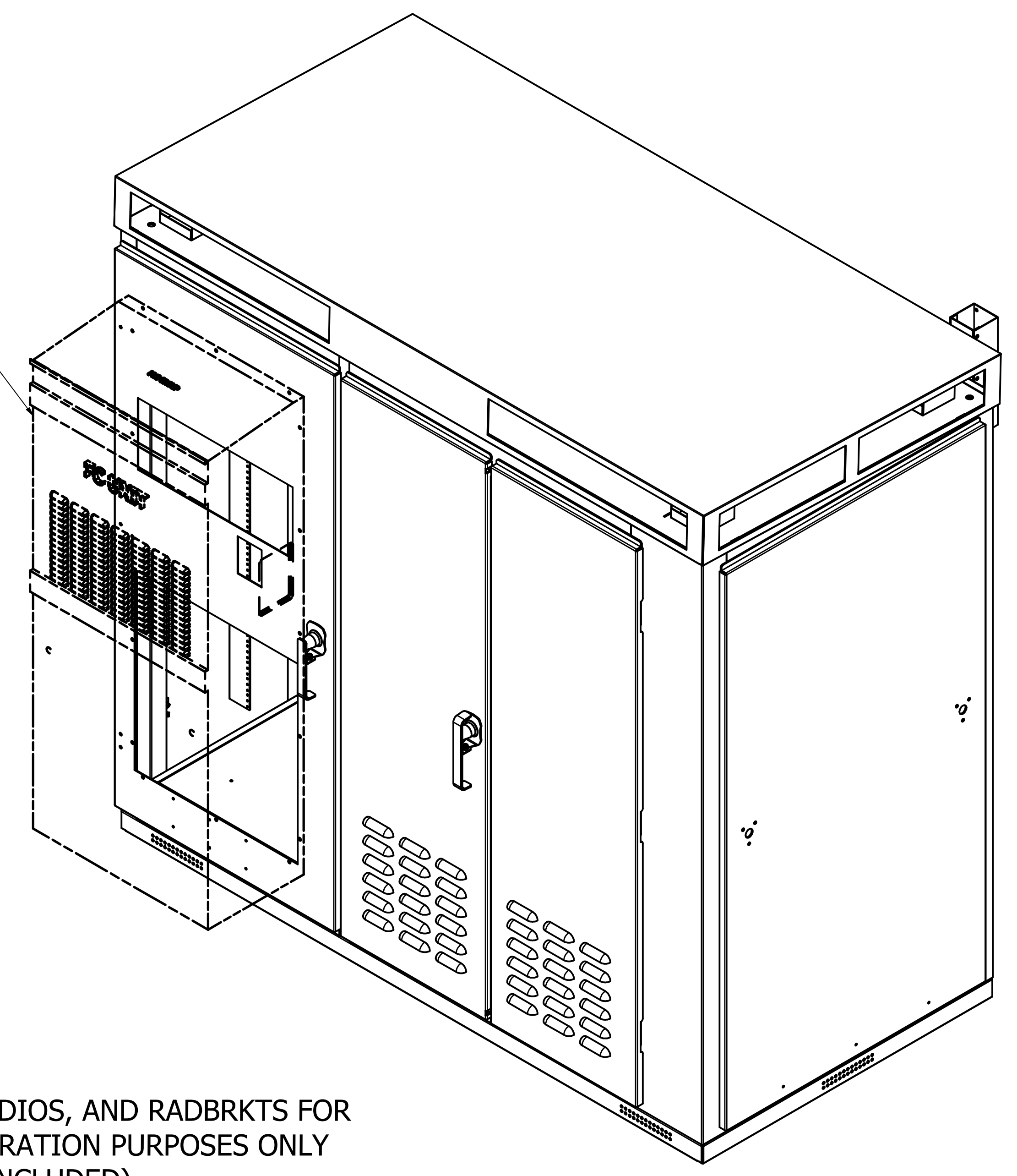

COLOUR: RAL7035 TXT WHITE.

The information contained herewithin is proprietary and confidential to R.F.MOTE LTD. It may not be reproduced or further disseminated, in whole or in part, without prior written consent from R.F.MOTE LTD.

R.F.MOTE LTD ENGINEERED SYSTEMS				214 NEWKIRK RD. RICHMOND HILL, ONTARIO L4C 3G7 PHONE (905) 884-5250 FAX (905) 737-5188
PROJECT				
PART NUMBER RFM-723670_BM				
DATE 15-Mar-21	SCALE 0.11 : 1	WEIGHT 1031.65 lbmass	REV 04	
AUTHOR Production		SHEET 1 OF 6		

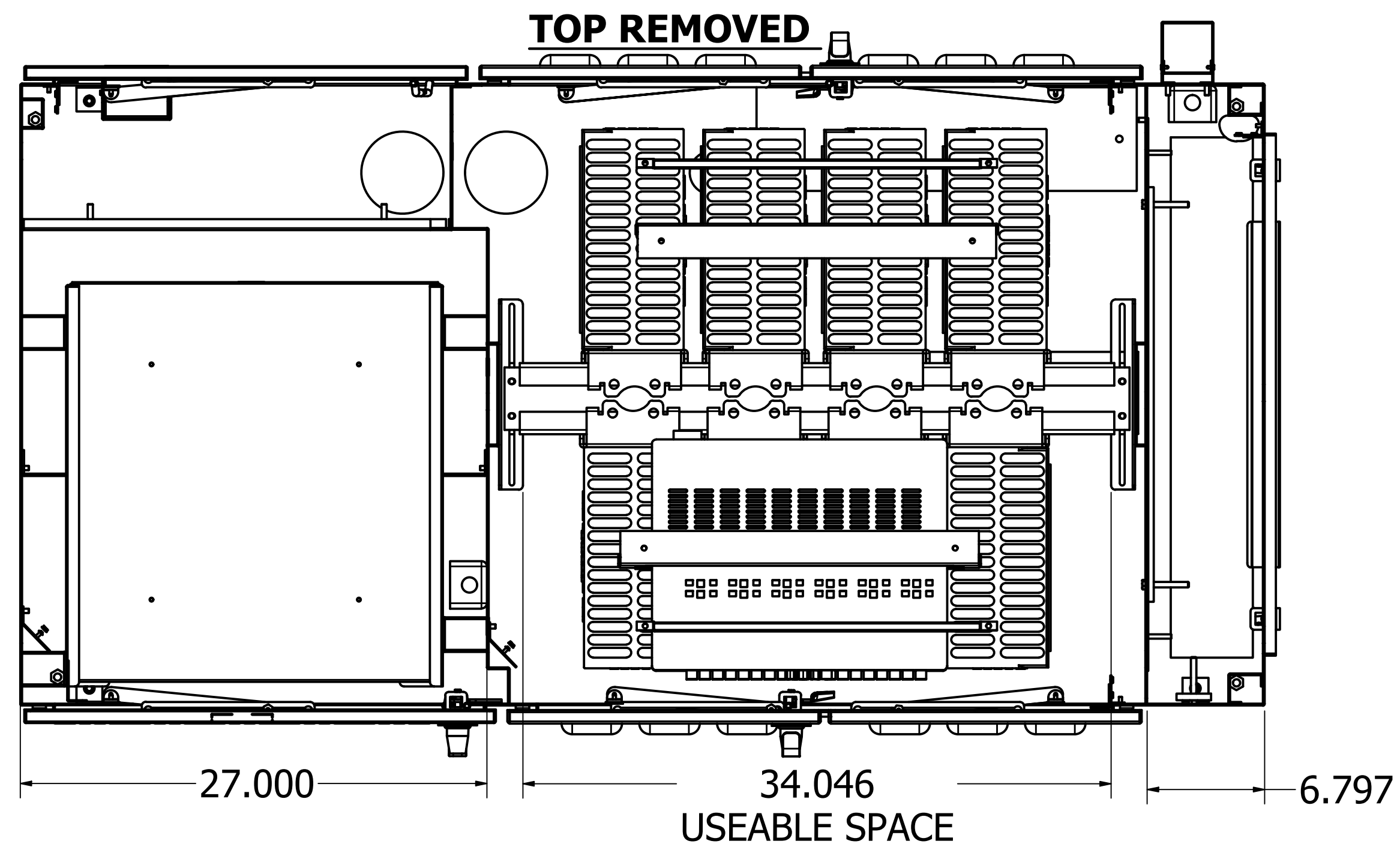

ALL RADBRKTS AND RADIOS FOR ILLUSTRATION PURPOSES ONLY
(NOT INCLUDED)

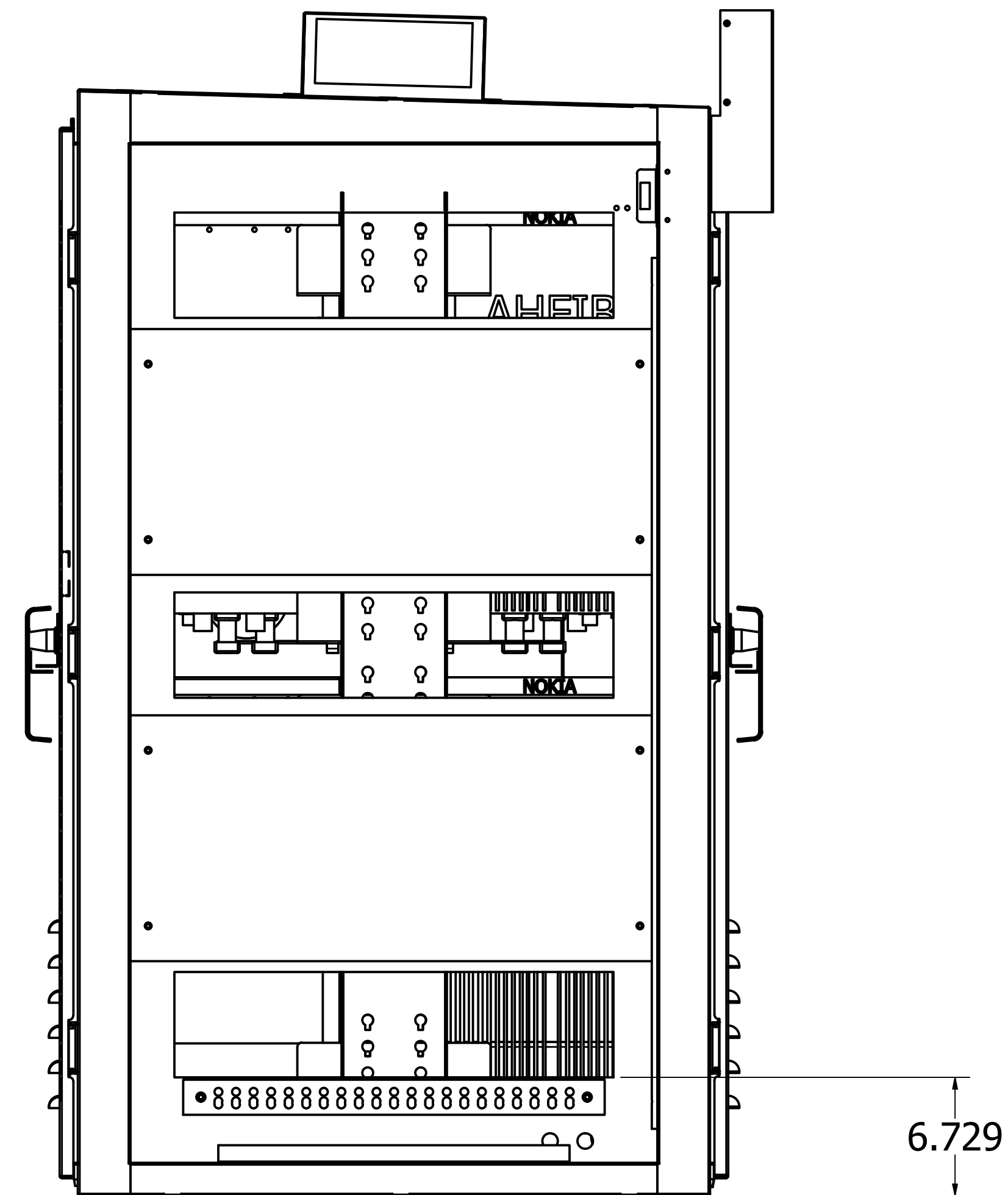
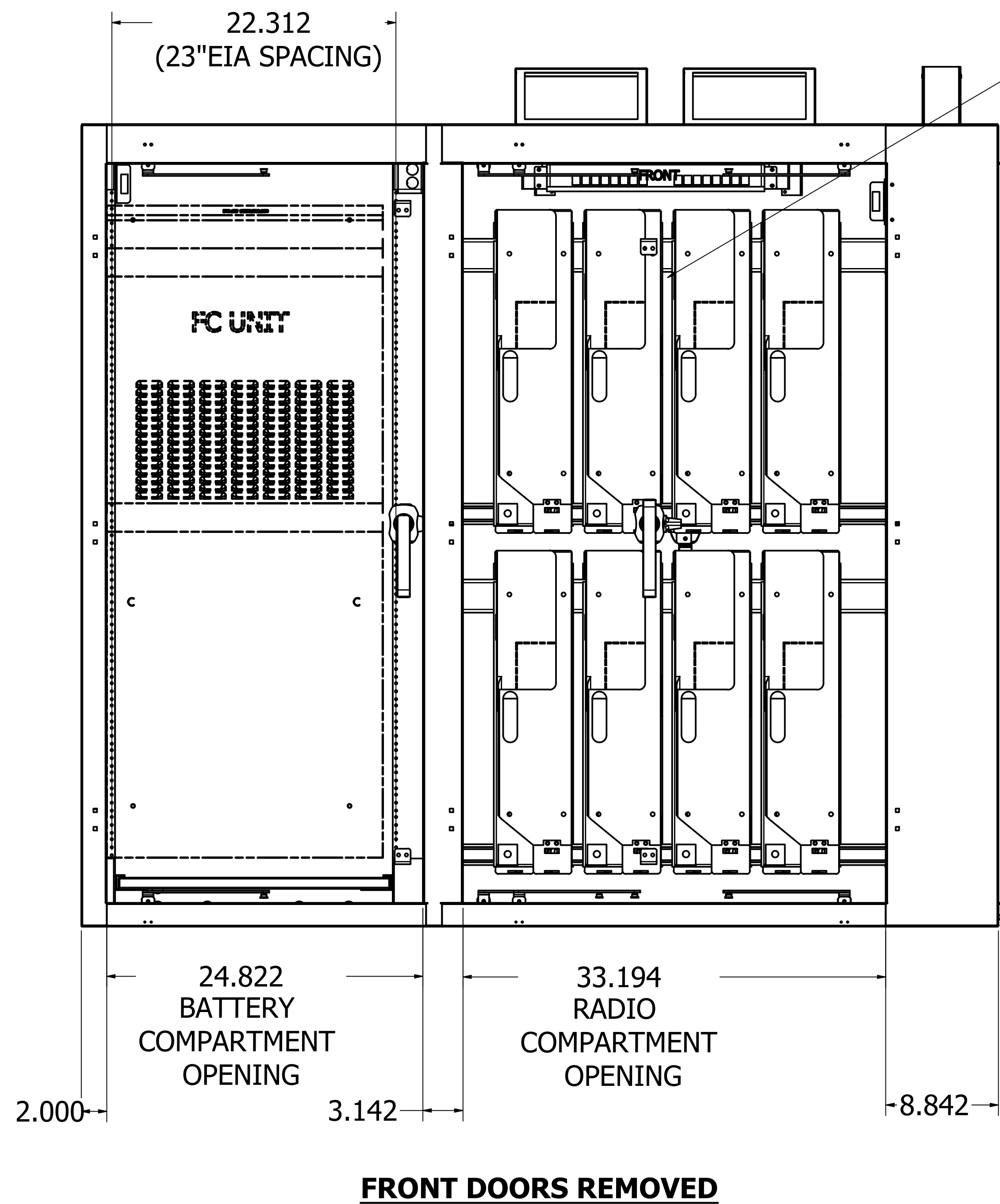

R.F.MOTE LTD
ENGINEERED SYSTEMS

214 NEWKIRK RD.
RICHMOND HILL, ONTARIO
L4C 3G7
PHONE (905) 884-5250
FAX (905) 737-5188

PROJECT			
PART NUMBER			
RFM-723670_BM			
DATE	SCALE	WEIGHT	REV
15-Mar-21	0.15 : 1	1031.65 lbmass	04
AUTHOR		SHEET 2 OF 6	
Production			

The information contained herewithin is proprietary and confidential to **R.F.MOTE LTD.** It may not be reproduced or further disseminated, in whole or in part, without prior written consent from **R.F.MOTE LTD.**

PROPOSED RADIO SUPPORT ARRANGMENT

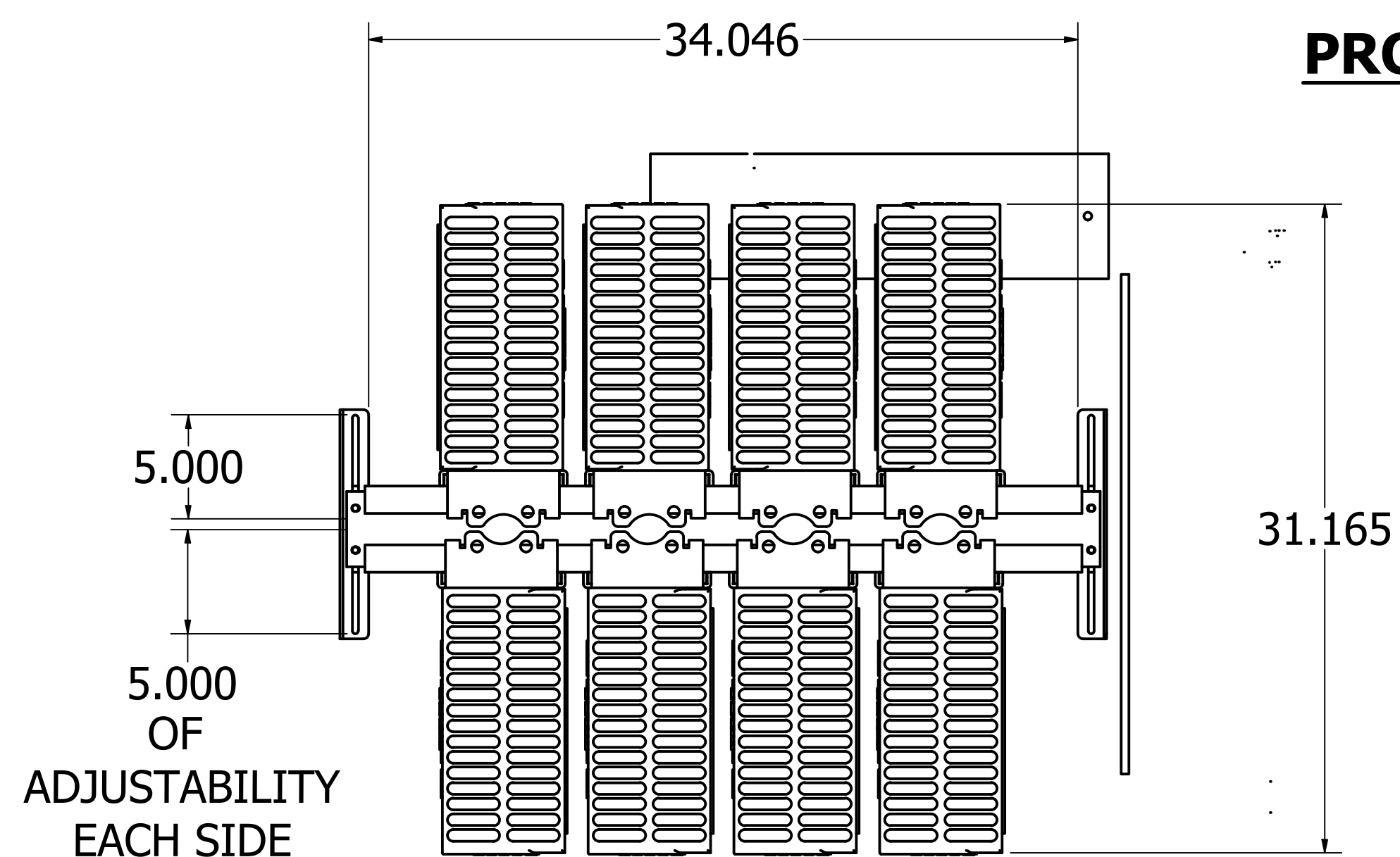

UNISTRUT FOR EASE OF TIGHTENING RADIOS IN PLACE USING M12 SPRING WASHERS

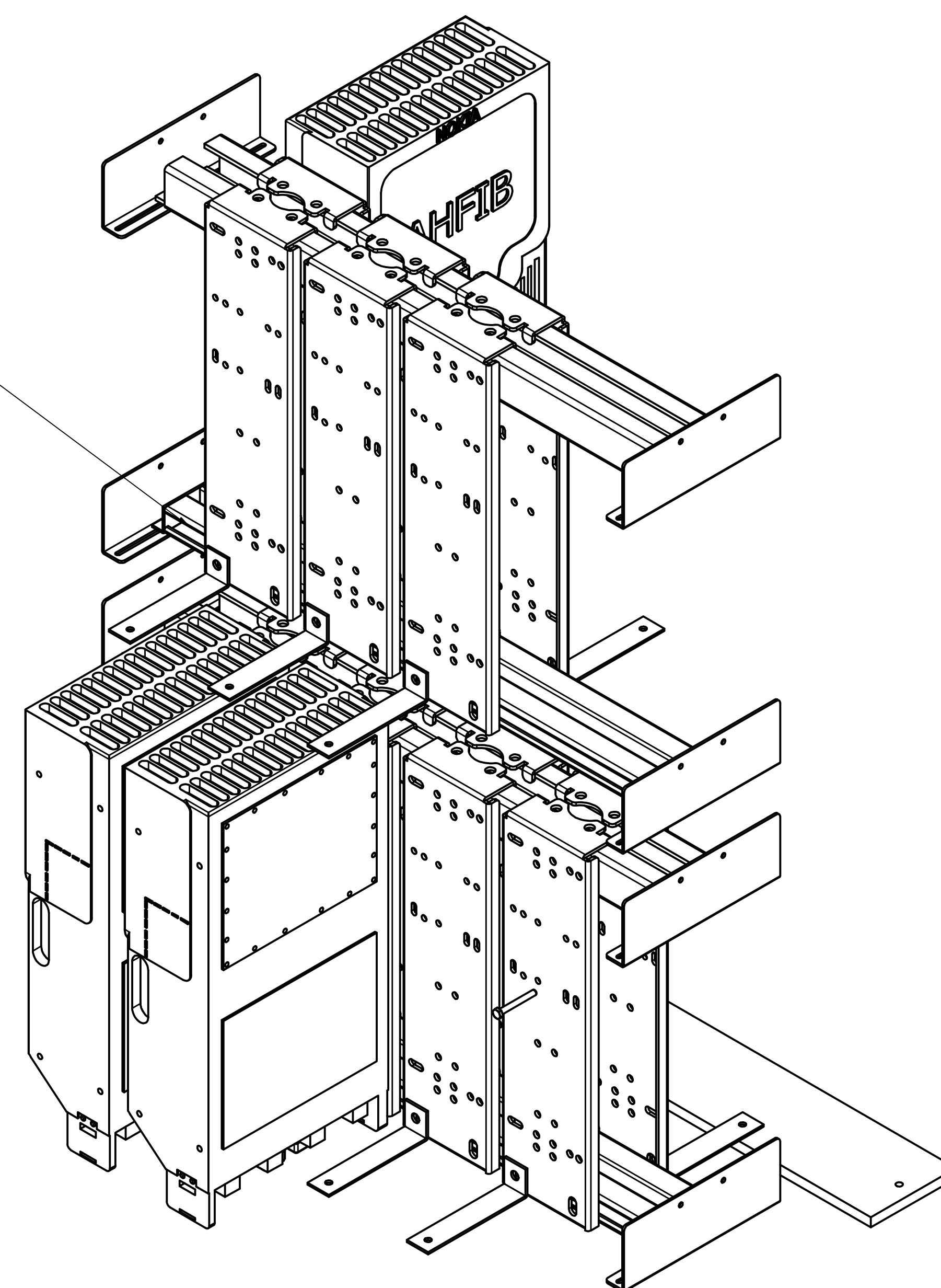

NOKIA AHFIB MOUNTED ON RADBRKT3-UNI FOR VISUAL PURPOSE ONLY

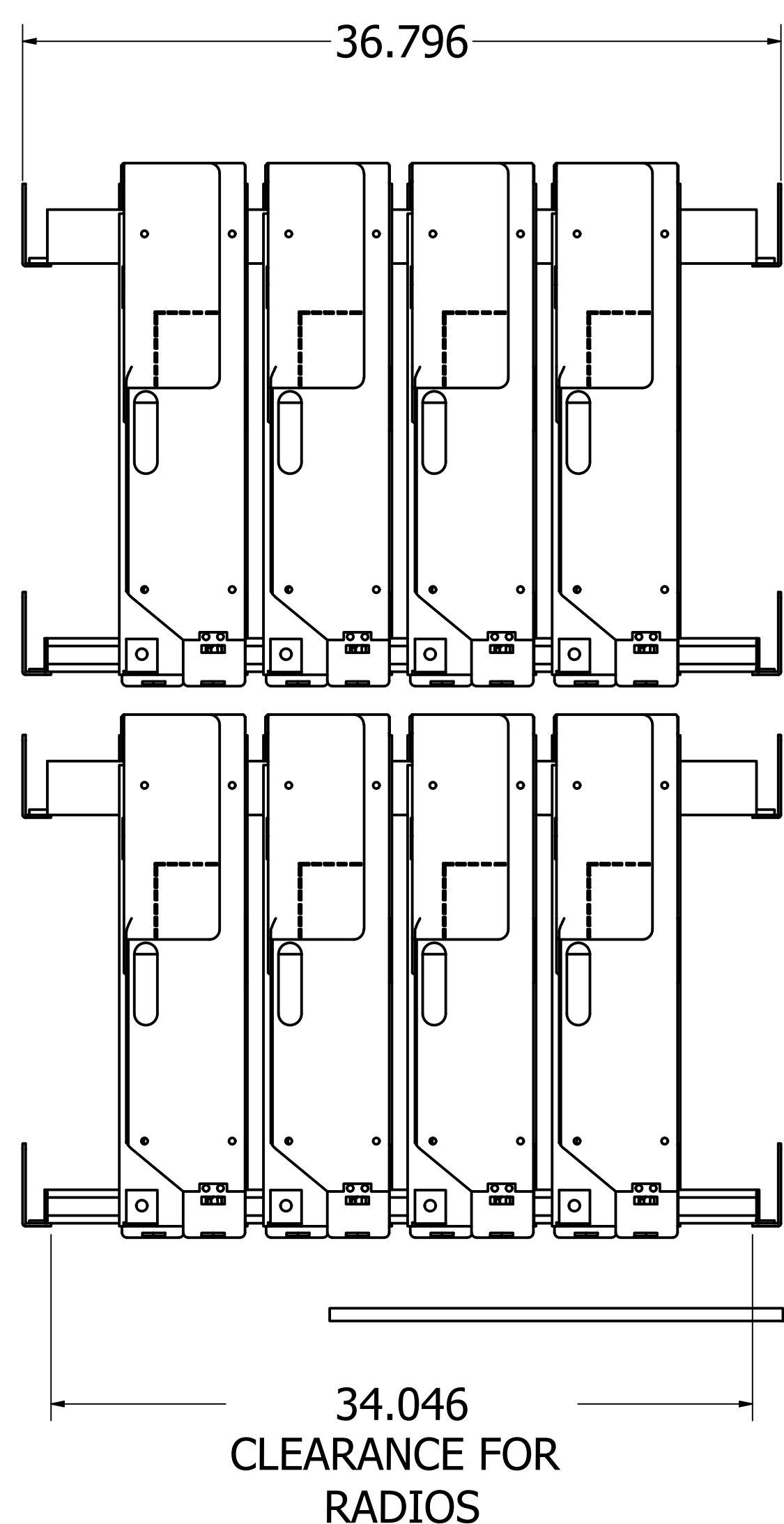

EXTRA HOLES ADDED TO MOVE RADIOS UP OR DOWN BY 1.5" INCREMENTS. 6" OF VARIABLE SPACE

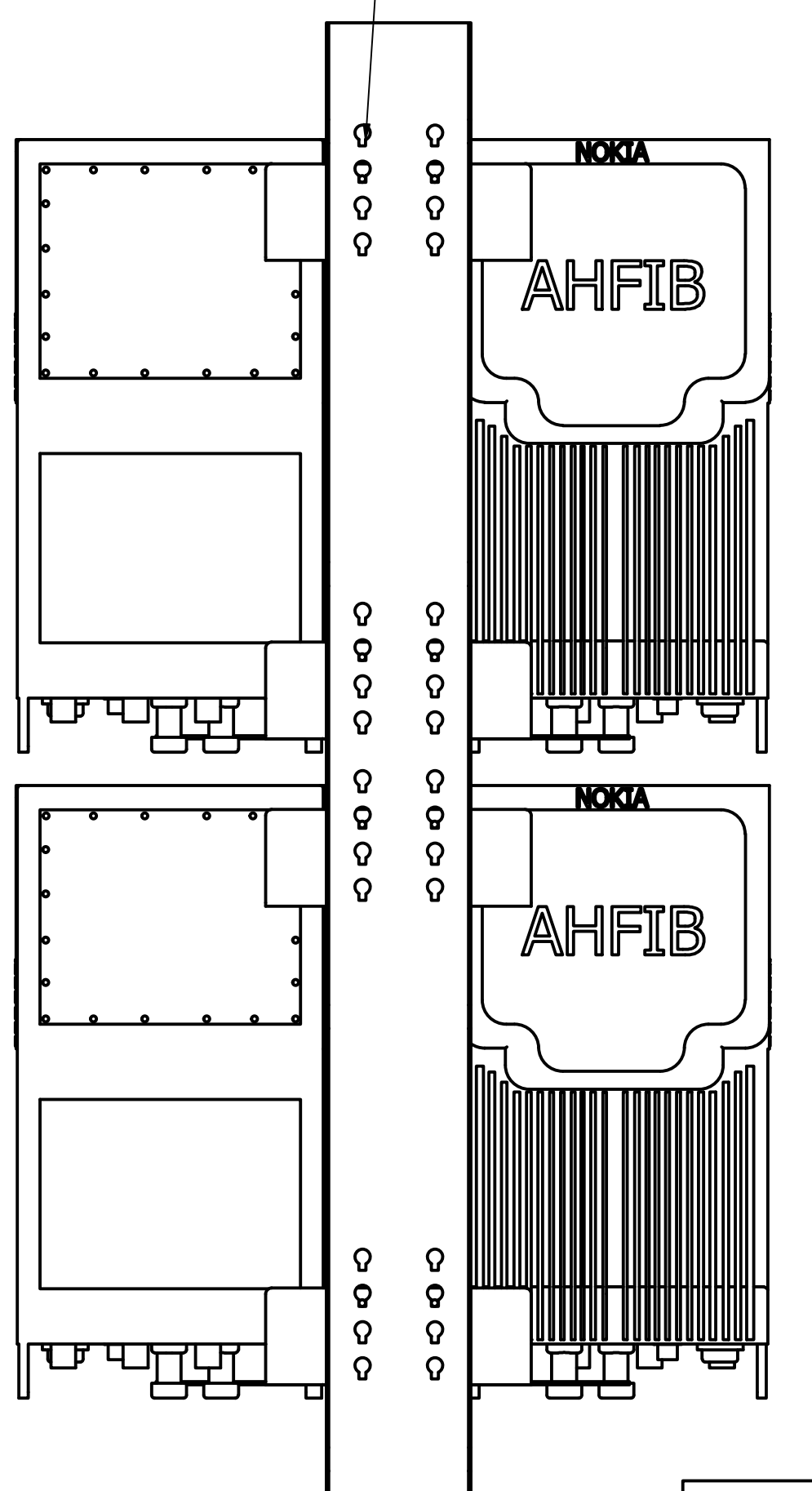

The information contained herewithin is proprietary and confidential to **R.F.MOTE LTD.** It may not be reproduced or further disseminated, in whole or in part, without prior written consent from **R.F.MOTE LTD.**

R.F.MOTE LTD ENGINEERED SYSTEMS				214 NEWKIRK RD. RICHMOND HILL, ONTARIO L4C 3G7 PHONE (905) 884-5250 FAX (905) 737-5188
PROJECT				
PART NUMBER				
RFM-723670_BM				
DATE	SCALE	WEIGHT	REV	
15-Mar-21	.2	N/A	04	
AUTHOR		SHEET 3 OF 6		
Production				

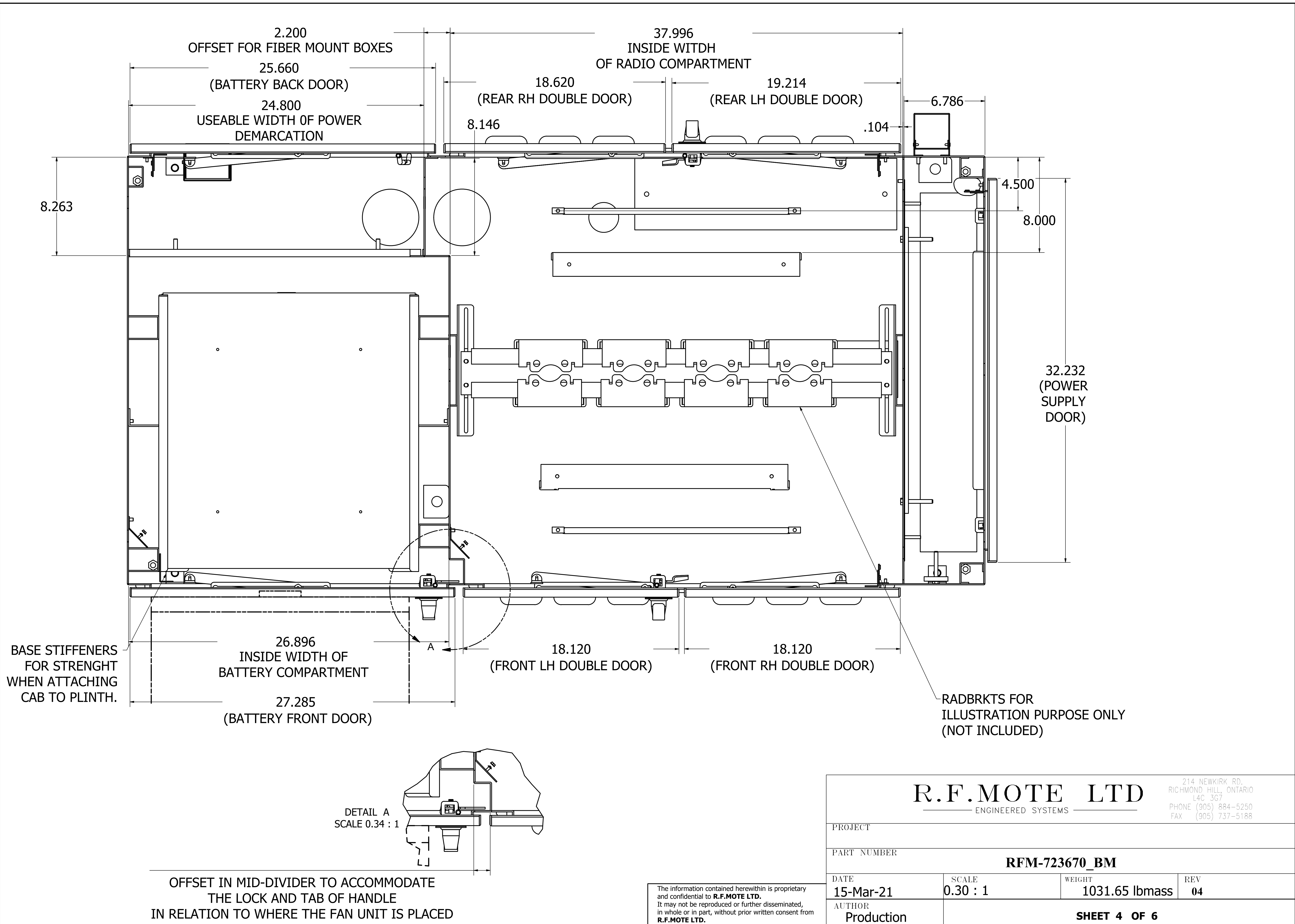

R.F.MOTE LTD
ENGINEERED SYSTEMS

214 NEWKIRK RD.
RICHMOND HILL, ONTARIO
L4C 3G7
PHONE (905) 884-5250
FAX (905) 737-5188

PROJECT			
PART NUMBER			
RFM-723670_BM			
DATE	SCALE	WEIGHT	REV
15-Mar-21	0.30 : 1	1031.65 lbmass	04
AUTHOR		SHEET 4 OF 6	
Production			

The information contained herewithin is proprietary and confidential to **R.F.MOTE LTD.** It may not be reproduced or further disseminated, in whole or in part, without prior written consent from **R.F.MOTE LTD.**

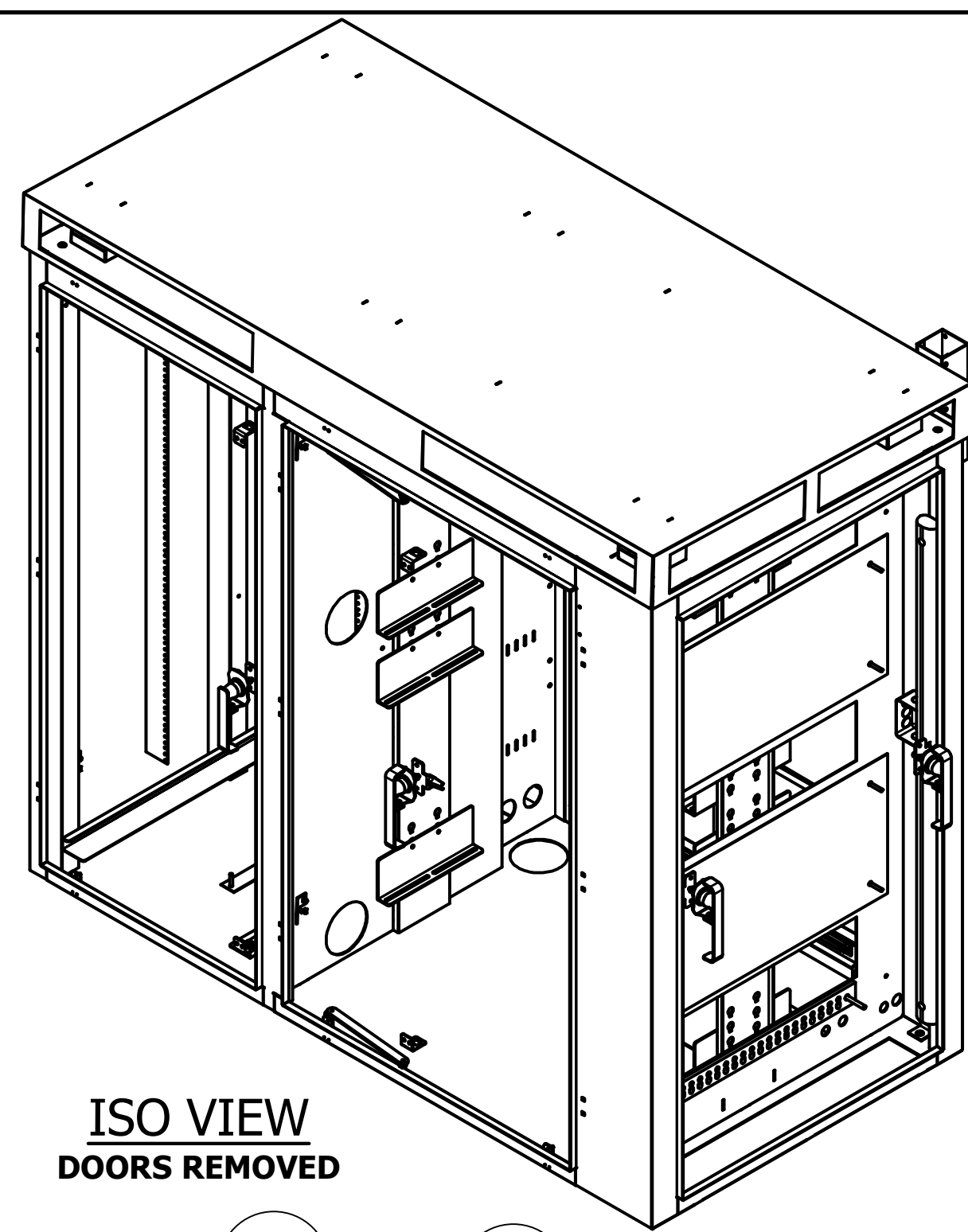

ISO VIEW
DOORS REMOVED

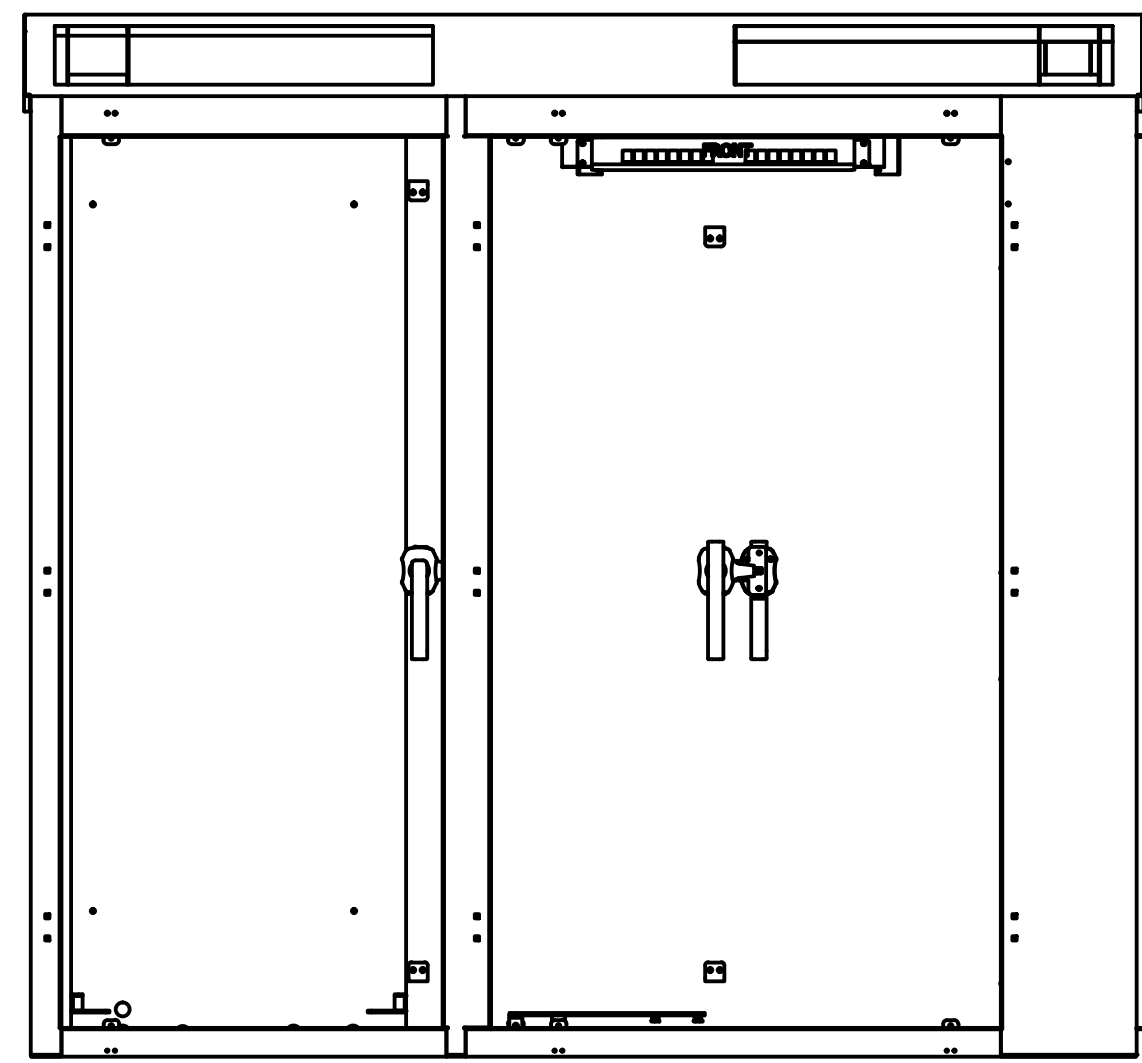

FRONT VIEW
DOORS REMOVED

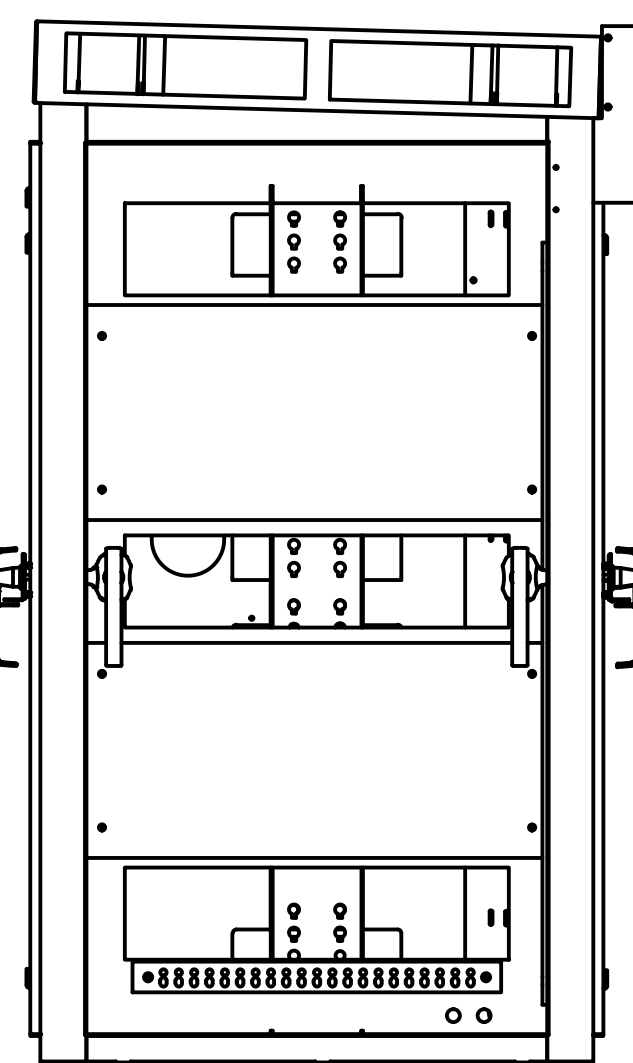

RIGHT SIDE VIEW
DOOR REMOVED

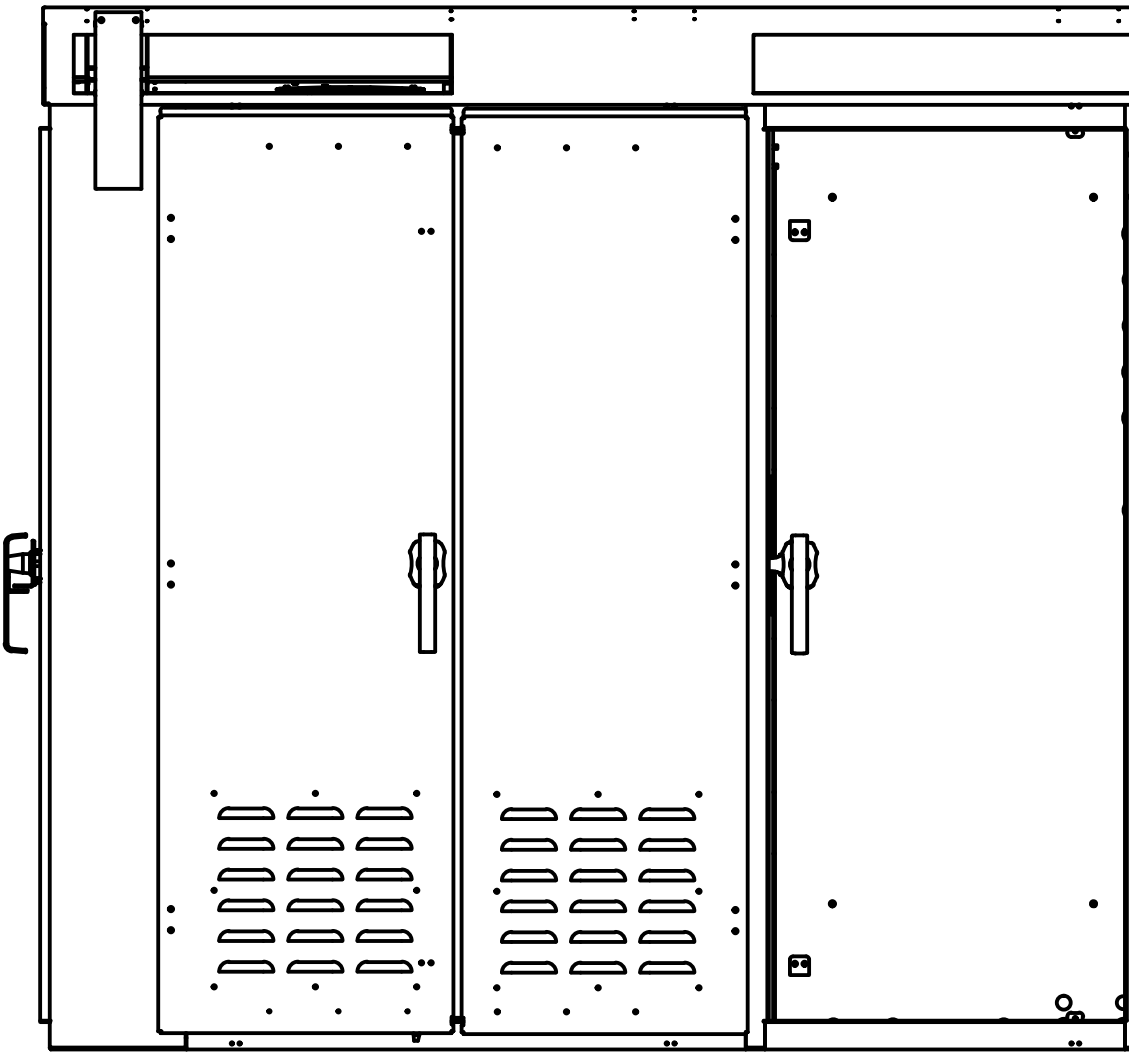

REAR VIEW
BACK BATTERY DOOR
REMOVED

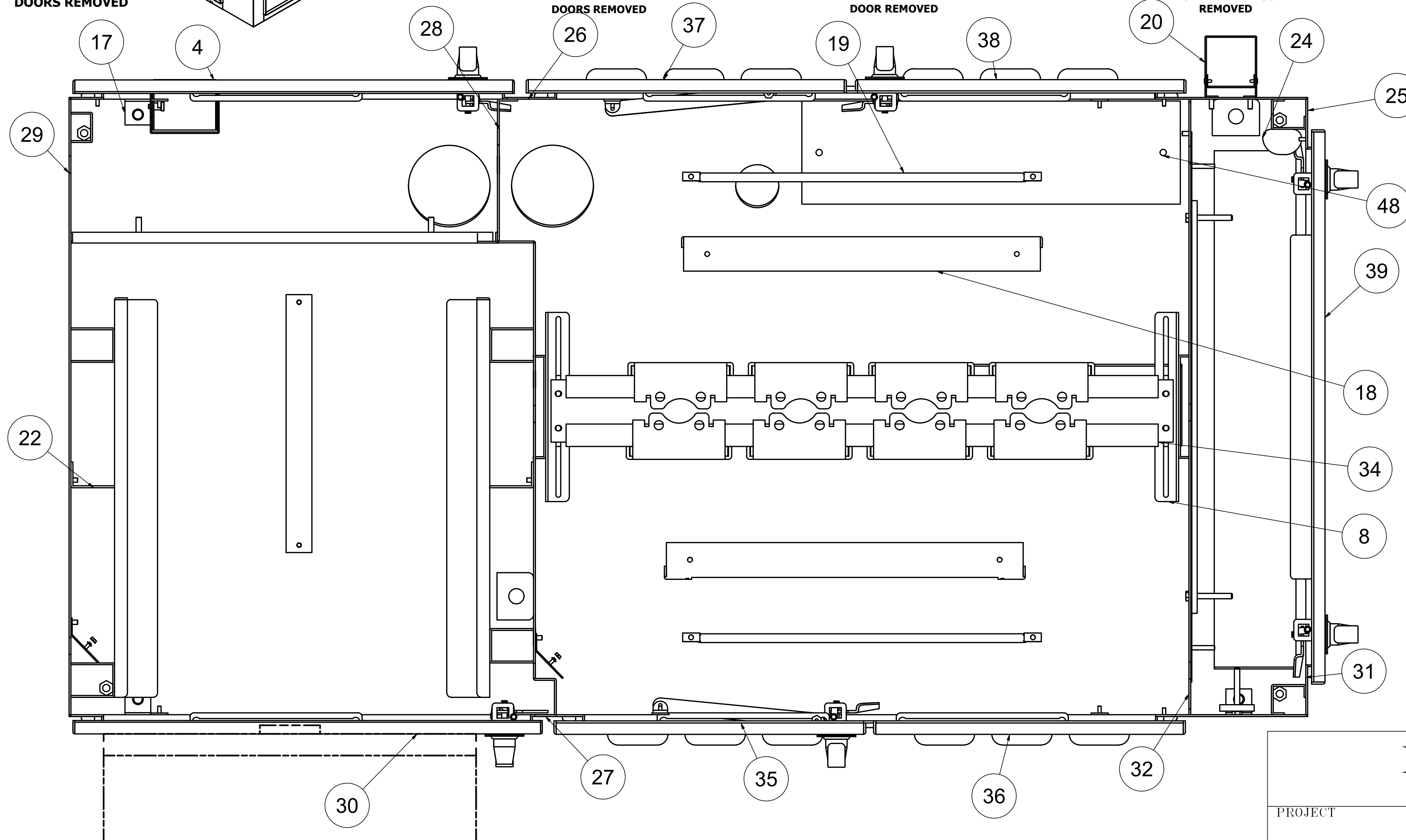

TOP VIEW
FANHOOD & TOP REMOVED

PARTS LIST		
ITEM	QTY	PART NUMBER
1	1	RFM-723670-base
2	1	RFM-BM-SRC-Bottom Right Wall
3	1	RFM-723670-TOP
4	1	RFM-723670-BACK BATT DOOR ASSY
5	4	RFM-BM-SRC-MicroSwitchBrkt-2
6	12	RFM-BM-SRC-DOOR STAY-1
7	16	RFM-BM-SRC-DOOR STAY BRK-1
8	8	RFM-603660-RADIO MTG ANGLE
9	1	RFM-723670-PLINTH
10	1	RFM-723670-BM-FAN HOOD, WELDMENT
11	1	RFM-603660-TOP Right Wall
12	4	RFM-BM-603660-SENSOR-BRKT-1
13	4	RFM-543660-BM-FAN HOOD RUBBER WASHER
14	1	RFM-BM-AC-MicroSwitchBrkt-2A
15	1	RFM-723670-BM-TEMPLATE
16	1	RFM-BM-SRC-BatteryShelf
17	4	RFM-603660-BASE-STIFF
18	2	RFM-603660-BM-19-1U
19	2	RFM-603660-BM-CABLE-SUPPORT
20	1	RFM-BM-GPS-CHANNEL
21	2	RFM-BM-R250-FANBOX
22	1	RFM-BM-723660-RACK RAIL-LH
24	4	48_LIGHT (NOT SUPPLIED)
25	1	RFM-723670-Back Right Wall
26	1	RFM-723670-backMullion
27	1	RFM-723670-FrontMullion
28	1	RFM-723670-MidDivider,weldment
29	1	RFM-723670-LeftWall, WELDMENT
30	1	RFM-723670-FRONT BATT DOOR ASSY
31	1	RFM-723670-FRONT RIGHT WALL
32	1	RFM-723670-POWER DIVIDER ASSY
33	1	RFM-723670-BatteryBack Panel
34	2	RFM-723670-Radio Assly
35	1	RFM-723670-FRONTDOUBLEDOOR-1 ASSY
36	1	RFM-723670-FRONTDOUBLEDOOR-2 ASSY
37	1	RFM-723670-REARDOUBLEDOOR-2 ASSY
38	1	RFM-723670-REARDOUBLEDOOR-1 ASSY
39	1	RFM-723670-POWER SUPPLY DOOR ASSY
45	2	RFM-543660-GB
46	1	RFM-BM-723660-RACK RAIL-RH
47	1	RFM-BM-FS HEATER STRIP PLATE
48	1	RFM-723670-CABLE-PLY WOOD

R.F.MOTE LTD
ENGINEERED SYSTEMS

214 NEWKIRK RD.
RICHMOND HILL, ONTARIO
L4C 3G7
PHONE (905) 884-5250
FAX (905) 737-5188

PROJECT

PART NUMBER

RFM-723670_BM

DATE
15-Mar-21

SCALE
0.08 : 1

WEIGHT
1031.65 lbmass

REV
04

AUTHOR
Production

SHEET 5 OF 6

The information contained herewithin is proprietary and confidential to **R.F.MOTE LTD.** It may not be reproduced or further disseminated, in whole or in part, without prior written consent from **R.F.MOTE LTD.**

REVISION HISTORY FOR RFM-723670-BM-TEMPLATE

REV	DESCRIPTION	DATE	APPROVED
01	RELOCATED CONDUIT MTG HOLES AND ADDED RECTANGLE CUTOUT. ADDED (4x) .562" HOLES FOR PLINTH BOLT DOWN REFERENCED FROM THE 543660 ROW CAB. CHANGES MADE TO RFM-723670-BM-TEMPLATE ON PAGE 6	2021-04-26	Voula
02	ADDED (4x) .562" HOLES FOR PLINTH BOLT DOWN REFERENCED FROM THE 543660 ROW CAB PLINTH	2021-05-03	JG
03	PUNCHED "TOP"	26-JUL-21	JG
03	MODIFIED DOORS FOR ROLLER WHEEL ASSEMBLY, AND FRONT BATT DOOR FOR PLC GROUP FC UNIT. HEATER CABLE HOLE ADDED TO BATTERY BACK PANEL. RECEPTICLE MOVED UP TO 1.5 INCHES FROM TOP IN THE BATTERY COMPARTMENT. HEATER STRIP ADDED.	07-Oct-22	JG
04	CUTOUTS IN FRONT BATT DOOR MOVED UP 2". PLYWOOD PIECE ADDED FOR CORD FASTENING.	17-Oct-22	JG

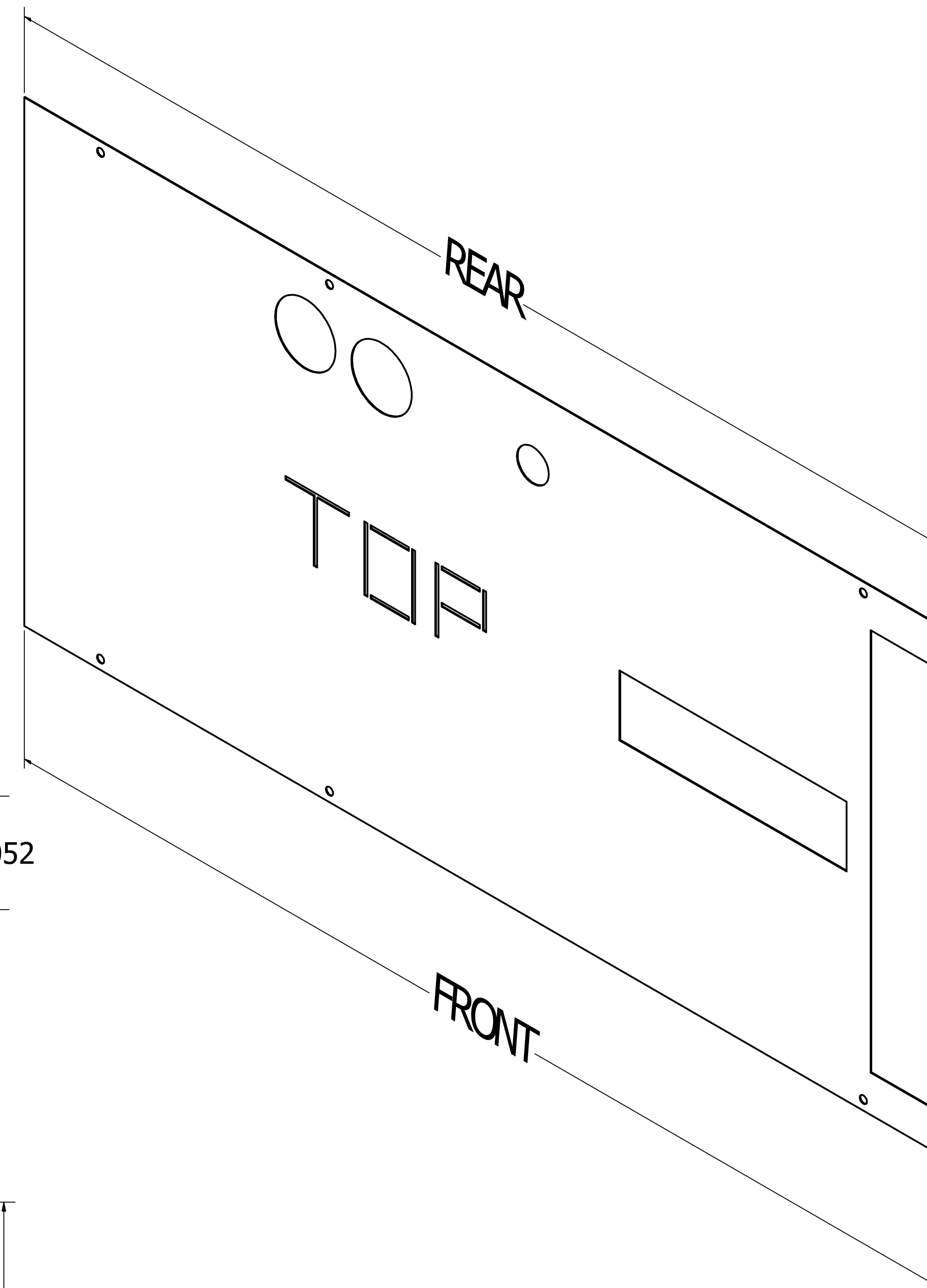
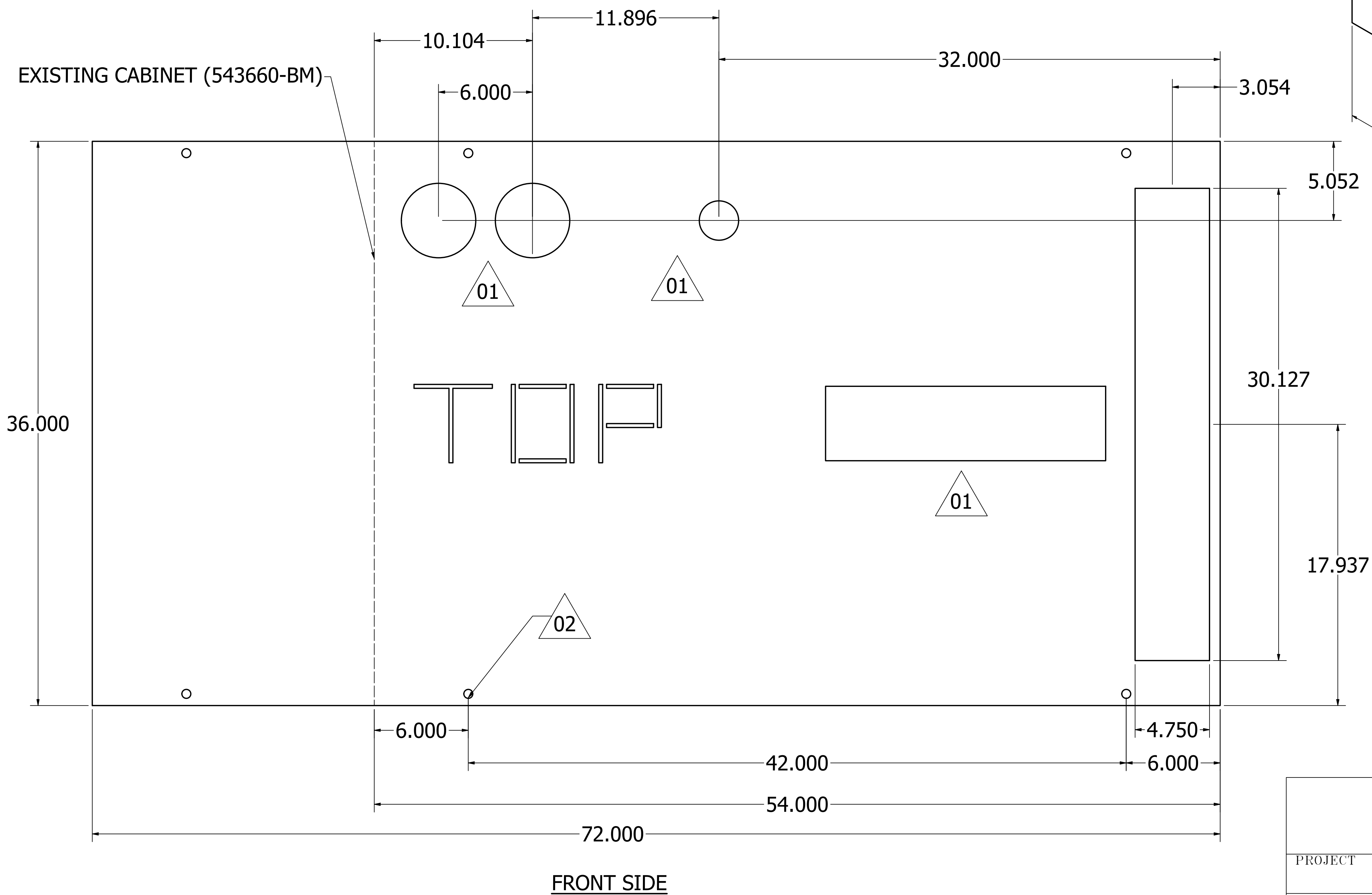

R.F.MOTE LTD
ENGINEERED SYSTEMS

214 NEWKIRK RD.
RICHMOND HILL, ONTARIO
L4C 3G7
PHONE (905) 884-5250
FAX (905) 737-5188

PROJECT			
PART NUMBER RFM-723670-BM-TEMPLATE			
DATE 15-Mar-21	SCALE 1 / 4	WEIGHT 39.40 lbmass	REV 03
AUTHOR Production		SHEET 6 OF 6	

The information contained herewithin is proprietary and confidential to **R.F.MOTE LTD.** It may not be reproduced or further disseminated, in whole or in part, without prior written consent from **R.F.MOTE LTD.**