

CUSTOMER: P/N: 3513.039 REV. APPROVED BY:

REVISIONS		
REV.	DESCRIPTION	DATE
△		2013/03/14
△		2015/06/04
△		2015/07/03
△		2018/01/30
△	Change the safety wire spec and increase the spec label	2022/09/27

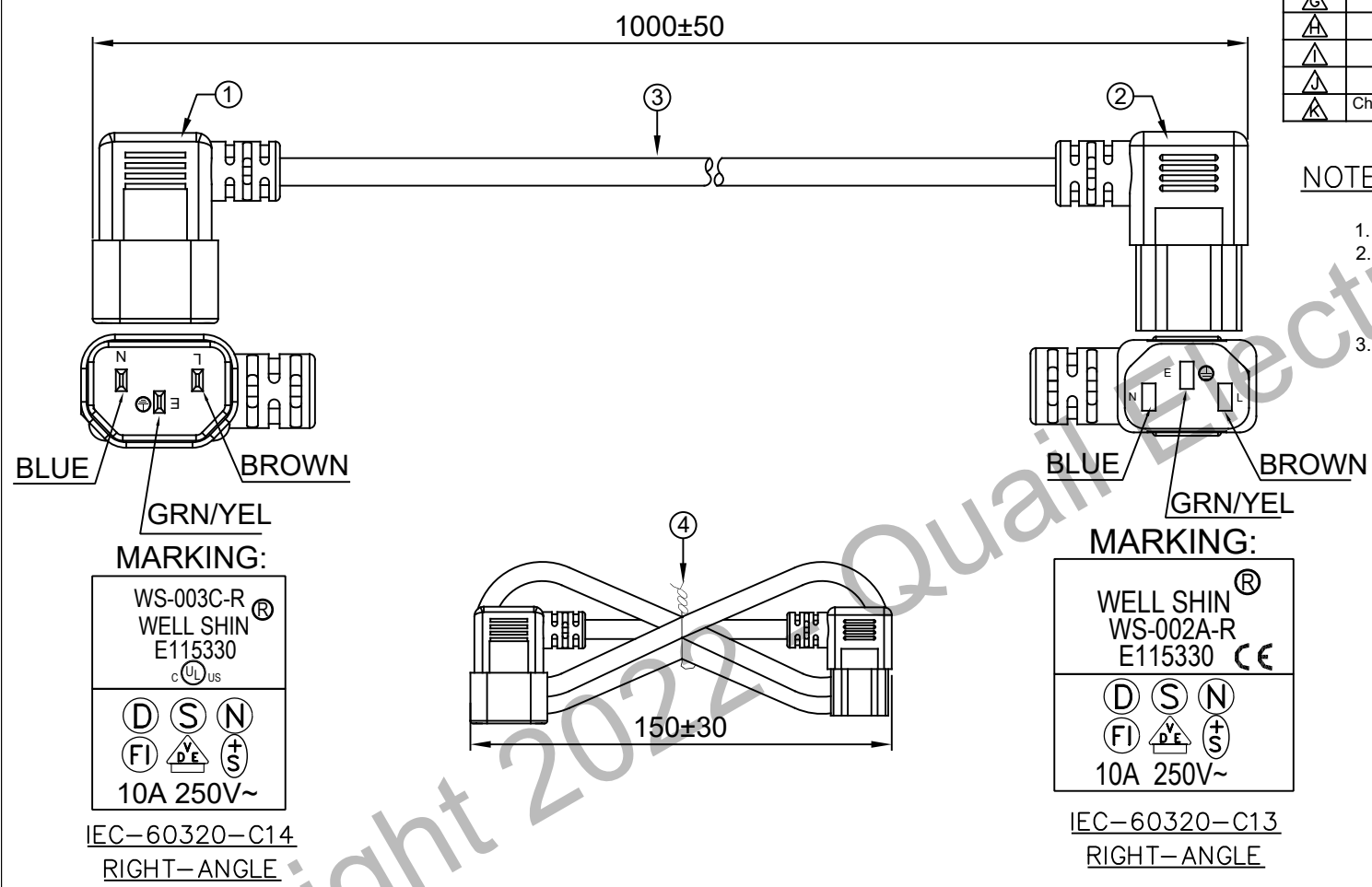

NOTES:

1. Add "CE" MARK to WS-002A-R and wire.
2. Changhua production wire has CSA safety regulations (the cable has CSA on ZH(Zhang Hwa) factory)
Changhua production starts from REV E
ZH(Zhang Hwa) factory begin from REV E
3. The outer box must be marked with RoHS (RoHS shown on the carton)

ITEM	DESCRIPTION	COLOR	QTY
④	Cable tie	BLACK	1
③	SJTW 17AWG 3C 105°C + H05VV-F 3G 1.0MMSQ + 60227 IEC 53(RVV) 300/500 3G 1.0MMSQ APPROVAL: UL, CUL(CSA), EUROPEAN, CCC, CE	BLACK	1
②	WS-002A-R 10(A) 250(V) APPROVAL: UL, CUL, EUROPEAN, CE	BLACK	1
①	WS-003C-R 10(A) 250(V) APPROVAL: UL, CUL, EUROPEAN	BLACK	1

頭	尾	線種	線規	芯線數	溫度	顏色	總長度	
WS-003C-R	WS-002A-R	SJTW+H05VV-F+60227 IEC53(RVV)	17AWG+1.0MMSQ	3G	105°C	BLACK	1000mm	
SIGNATURE		QUAIL ELECTRONICS, INC.® http://www.quail.com						
ENGINEER BY:								
MANAGER BY:								
CHECKED BY:								
DRAWN BY:		PRODUCT NO.:	DATE: 2022/09/27		UNIT: mm		SHEET: 1 OF 1	REV
		DWG NO: 0096-0593		K				