



Now Available
in Single Reel
Order Quantities!

Heyco® Male Pins

For mating Female Pin & Connectors, see pages 8-47 thru 8-49



• DFARS Compliant

Dia. in.	PART DATA			PART NO.		APPLICATION TOOLING*				
	Overall Length in.	AWG Range	Material		Die**	Feeds	Tool Packs	Crimp Punch	Anvil	
MP125 Series										
.125	.63	20-18	Brass	7062	7062UXX5	Left to Right	B300L/B301L	C229	C231	
	.75	20-18	Brass Tin-PI	7060 7061	7060UXX5 7061UXX5					
	1.00	20-18	Brass Tin-PI	7064 7065	7064UXX5 7065UXX5					
	.75	16-14	Brass Tin-PI	7068 7069	7068UXX5 7069UXX5	Left to Right	B304L/B305L	C230	C232	
	1.00	16-14	Tin-PI Tin-PI	7073 7076†	7073UXX5 7076UXX5					
MP141 Series										
.141	1.03	18-16	Brass	7171	7171UXX5	Left to Right	B340L/B341L	C135	C138	
MP156 Series										
.156	1.03	18-16	Brass Tin-PI	7181 7183	7181UXX5 7183UXX5	Left to Right	B340L/B341L	C135	C138	
	1.31	18-16	Brass	7180	7180UXX5					
MP178 Series										
.178	1.39	18-14	Brass	7194	7194UXX5	Right to Left	B360R/B361R	C001	C009	
			Tin-PI	7195	7195UXX5					
		12-10	Brass Tin-PI	7192 7193	7192UXX5 7193UXX5					

* Heyco high volume Application Tooling, designed for 3-5 ton presses - see page 8-59.
 Heyco Mini Applicators, designed for 1.5-3 ton bench top presses, are available - see page 8-59.
 ** "XX" represents Wire Gauge. Please specify Wire Gauge when ordering.
 † Split on seam: pin will flex closed when in contact for a stronger connection.

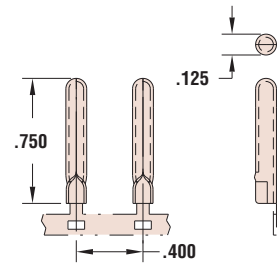

MP125 Series

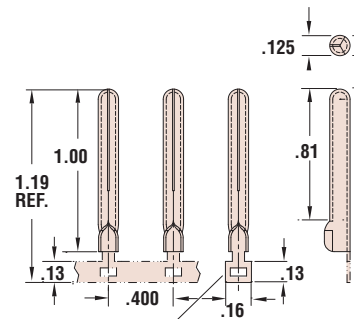

NOTE: OPTIONAL CUT OFF ON ASSY. EQUIPMENT

MP125 Series 7076

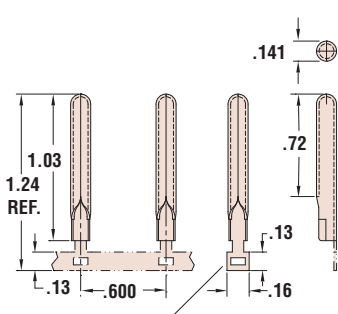

NOTE: OPTIONAL CUT OFF ON ASSY. EQUIPMENT

MP141 Series

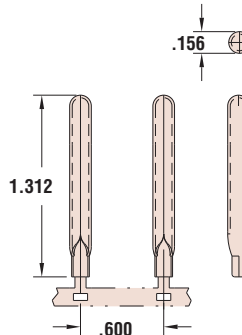

MP156 Series

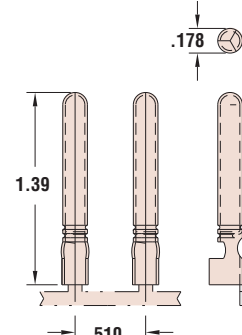

MP178 Series

Materials Alloy 260 Brass (70% Cu, 30% Zn. Higher Cu content resists dezincification)
 Tin-PI = Brass, Tin plated before or after stamping

*Quick
Specs*