

DESCRIPTION: 26/4 CABLE 80C 300V UNITS: IN SCALE: 24:1

NORTHWIRE P/N: FCAB264-049

CUSTOMER: VAPOR BUS INTERNATIONAL APPR BY: REVD BY: DL DWG NO: 80617-2

CUSTOMER P/N: TBD DRAWN BY: A. MEJIA DATE: 5/10/2023 REV: A

CORE DIMENSIONS FOR INTERNAL USE ONLY

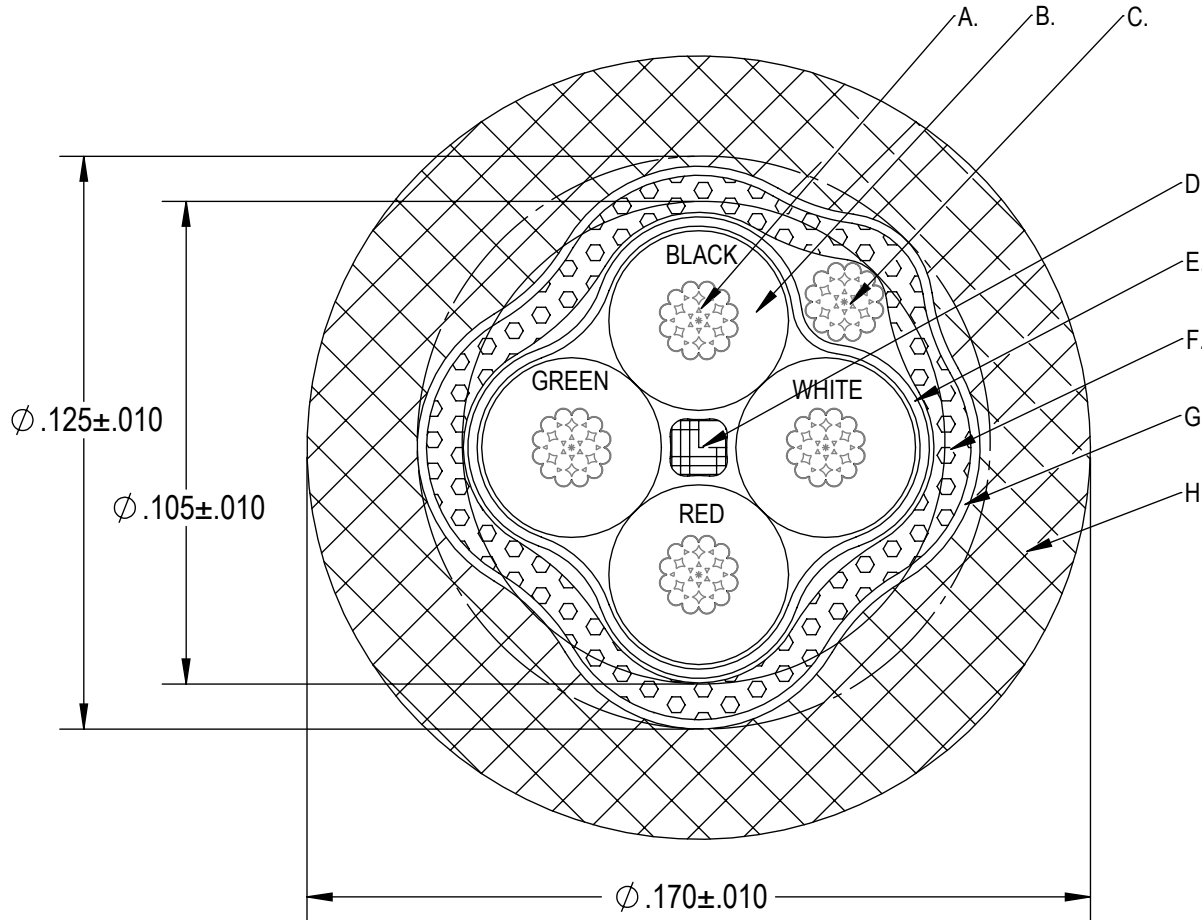

ITEM	SPECIFICATIONS
A.	26 AWG 19x.004 TC
B.	8 MILS POLYESTER (HYTREL) INSULATION 6.5 MILS MIN POLYESTER (HYTREL) INSULATION OD: .039 ± .002"
C.	26 AWG 19x.004 TC DRAIN WIRE
D.	COTTON FILLER
E.	PTFE FLEX FACILITATING TAPE WRAP
F.	36 AWG TC BRAIDED SHIELD (85% MIN COVERAGE)
G.	PTFE FLEX FACILITATING TAPE WRAP
H.	15 MILS PRESSURED TPU JACKET 12 MILS MIN PRESSURED TPU JACKET JACKET COLOR: BLACK
CABLE IS NOT UL OR CSA CERTIFIED	
ROHS3 DIRECTIVE (EU) 2015/863 TO AMEND ANNEX II TO EU ROHS 2, 2011/65/EU WITH NO EXEMPTIONS	

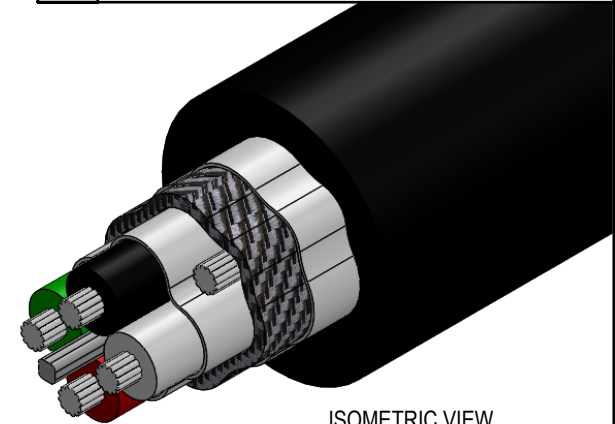

ISOMETRIC VIEW
FOR REFERENCE ONLY

LEGEND SPECIFICATIONS - NO LEGEND ON CABLE

OSCEOLA: N/A

SANTA TERESA: N/A



This document contains proprietary and confidential information of Northwire, Inc. (and its subsidiary) and shall not be used, disclosed or reproduced, in whole or in part, for any purpose without the prior written consent of Northwire, Inc. (and its subsidiary).

Disclaimer: The technical data that is made part of this document may be subject to the International Traffic in Arms Regulation (ITAR) and the Export Administration Regulations (EAR). Disclosure of technical data to Foreign Persons in the course of employment with U.S. contractors is considered an export and is subject to the ITAR and EAR export licensing requirements/regulations.

DESCRIPTION: 26/4 CABLE 80C 300V	UNITS: IN	SCALE: 60:1	ELECTRICAL REQUIREMENTS
----------------------------------	-----------	-------------	-------------------------

NORTHWIRE P/N: FCAB264-049			
----------------------------	--	--	--

CUSTOMER: VAPOR BUS INTERNATIONAL	APPR BY: FCAB264-049	DWG NO: 80617-2	
-----------------------------------	----------------------	-----------------	--

CUSTOMER P/N: TBD	DRAWN BY: A. MEJIA	DATE: 5/10/2023	REV: A
-------------------	--------------------	-----------------	--------

NONE SPECIFIED

MECHANICAL REQUIREMENTS

HIGH FLEX LIFE CABLE: 10 MILLION CYCLES
 RECOMMENDED MIN BEND RADIUS:
 CONSTANT: 15X CABLE DIAMETER
 FIXED INSTALLATION: 7X CABLE DIAMETER

INITIAL DESIGN	A	22581	5/10/23	AM
REVISION RECORD	REV.	ECR NO.	REV DATE	APR
REVISIONS				