

Heyco® Heavy Duty Ground Pins – Female

For Heavy Duty Blades, see pages 8-27 & 8-28



Overall Length in.	PART DATA			PART NO.	APPLICATION TOOLING*				
	Shape	AWG Range	Material		Die**	Feeds	Tool Packs	Crimp Punch	Anvil
250 Series - designed to mate with .250" (6,4 mm) outside diameter Heavy Duty Male Pins									
1.18	D	14-10	Brass	8243	8243UXX5	Left to Right	B966L/B967L	C388	C391
1.22	O	10-6	Tin-Pl	8246	8246UXX5	Left to Right	B974L/B975L		
1.72	O	10-6	Tin-Pl	8245	8245UXX5	Left to Right	B952L/B953L	C640	C647
	D	10-6	Brass	8244	8244UXX5				

- Specify **D-shaped Barrel** parts for the most secure connection.
- DFARS Compliant

* Use the Heyco Universal Applicator Die (indicated by "U" in the Die Part No.), page 8-59.
 ** "XX" represents Wire Gauge. Please specify Wire Gauge when ordering.

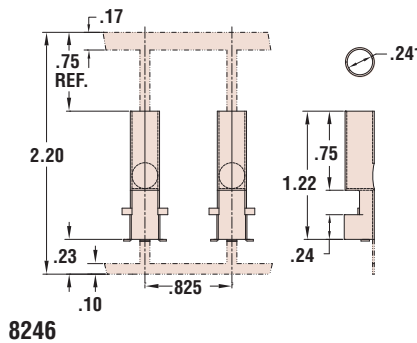
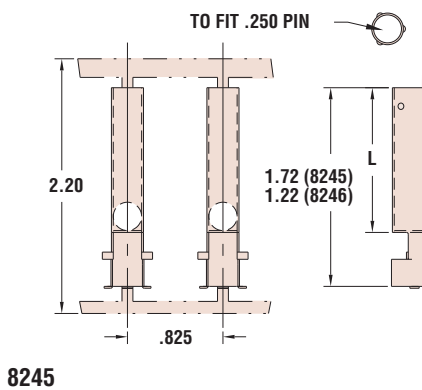
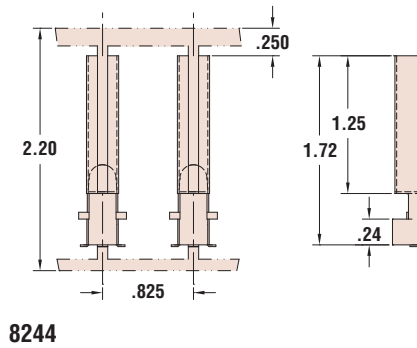
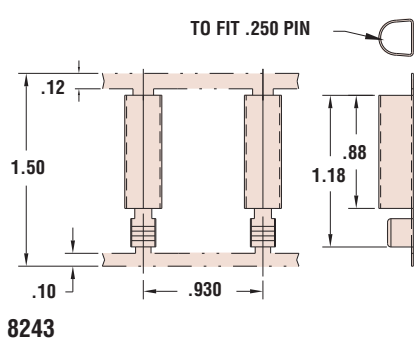

Materials

Alloy 260 Brass (70% Cu, 30% Zn. Higher Cu content resists dezincification)
 Tin-Pl = Brass, Tin plated before or after stamping
 Post-Ni = Brass, Nickel plated after stamping

Quick Specs