

KONALS

Models: LSe and LS

Installation and Operation Guide



AJA
AJA VIDEO SYSTEMS INC

May 31, 2006 P/N101656

Trademarks

AJA, KONA, and Io are trademarks of AJA Video, Inc.

Apple, the Apple logo, AppleShare, AppleTalk, FireWire and Macintosh are registered trademarks of Apple Computer, Inc. Final Cut Pro, QuickTime and the QuickTime Logo are trademarks of Apple Computer, Inc. DVCPRO HD® is a registered trademark of Panasonic Inc.

All other trademarks are the property of their respective holders.

Notice

Copyright © 2006 AJA Video, Inc. All rights reserved. All information in this manual is subject to change without notice. No part of the document may be reproduced or transmitted in any form, or by any means, electronic or mechanical, including photocopying or recording, without the express written permission of AJA Inc.

FCC Emission Information

This equipment has been tested and found to comply with the limits for a Class A digital device, pursuant to Part 15 of the FCC Rules. These limits are designed to provide reasonable protection against harmful interference when the equipment is operated in a commercial environment. This equipment generates, uses and can radiate radio frequency energy and, if not installed and used in accordance with the instruction manual, may cause harmful interference to radio communications. Operation of this equipment in a residential area is likely to cause harmful interference in which case the user will be required to correct the interference at his own expense. Changes or modifications not expressly approved by AJA Video can effect emission compliance and could void the user's authority to operate this equipment.

Contacting Support

To contact AJA Video for sales or support, use any of the following methods:

443 Crown Point Circle, Grass Valley, CA. 95945 USA

Telephone: 800.251.4224 or 530.274.2048

Fax: 530.274.9442

Web: <http://www.aja.com>

Support Email: support@aja.com

Sales Email: sales@aja.com

When calling for support, first read the Chapter on *Troubleshooting* at the back of this manual. You can often save time and effort by looking there first for simple remedies and information on how to get support from AJA and Apple Computer Inc.

Limited Warranty

AJA Video warrants that this product will be free from defects in materials and workmanship for a period of three years from the date of purchase. If a product proves to be defective during this warranty period, AJA Video, at its option, will either repair the defective product without charge for parts and labor, or will provide a replacement in exchange for the defective product.

In order to obtain service under this warranty, you the Customer, must notify AJA Video of the defect before the expiration of the warranty period and make suitable arrangements for the performance of service. The Customer shall be responsible for packaging and shipping the defective product to a designated service center nominated by AJA Video, with shipping charges prepaid. AJA Video shall pay for the return of the product to the Customer if the shipment is to a location within the country in which the AJA Video service center is located. Customer shall be responsible for paying all shipping charges, insurance, duties, taxes, and any other charges for products returned to any other locations.

This warranty shall not apply to any defect, failure or damage caused by improper use or improper or inadequate maintenance and care. AJA Video shall not be obligated to furnish service under this warranty a) to repair damage resulting from attempts by personnel other than AJA Video representatives to install, repair or service the product, b) to repair damage resulting from improper use or connection to incompatible equipment, c) to repair any damage or malfunction caused by the use of non-AJA Video parts or supplies, or d) to service a product that has been modified or integrated with other products when the effect of such a modification or integration increases the time or difficulty of servicing the product.

THIS WARRANTY IS GIVEN BY AJA VIDEO IN LIEU OF ANY OTHER WARRANTIES, EXPRESS OR IMPLIED. AJA VIDEO AND ITS VENDORS DISCLAIM ANY IMPLIED WARRANTIES OF MERCHANTABILITY OR FITNESS FOR A PARTICULAR PURPOSE. AJA VIDEO'S RESPONSIBILITY TO REPAIR OR REPLACE DEFECTIVE PRODUCTS IS THE WHOLE AND EXCLUSIVE REMEDY PROVIDED TO THE CUSTOMER FOR ANY INDIRECT, SPECIAL, INCIDENTAL OR CONSEQUENTIAL DAMAGES IRRESPECTIVE OF WHETHER AJA VIDEO OR THE VENDOR HAS ADVANCE NOTICE OF THE POSSIBILITY OF SUCH DAMAGES.



AJA VIDEO SYSTEMS INC

Table of Contents

Trademarks	ii
Notice	ii
FCC Emission Information	ii
Contacting Support	ii
Limited Warranty	iii
Table of Contents	1

Chapter 1: Introduction

Overview	1
LSe and LS Models	1
Features	2
Hardware	2
KONA LS Audio	2
Software	3
What's In The Box?	3
System Requirements	4
Minimum and Recommended System and Software Requirements	5
Understanding Disk Storage Methods	5
About RAIDs	7
Software For Striping	8
AJA KONA LS and Xserve RAID	8
Storage capacity	8
Cable Connections	9
Using the Standard Cables	9
Using KL-box	11
About BNC Connectors	11
Connector Descriptions—Cables and KL-box	11
2 Channel Digital AES/EBU Audio Inputs And Outputs	12
Analog 2 Channel Balanced Audio	12
Analog 2 Channel Unbalanced Audio (KL-box only)	12
RS422 Machine Control	12
SDI Input and Outputs	12
Analog Monitor Out (Component/Composite SD)	12
Reference Video	13
In This Manual	13

Chapter 2: Getting Started—Workflow

KONA LS And Your Workflow	15
Understanding Typical Workflows	16
PhotoJPEG	17
DV (DV25)	17
DV50	17
Uncompressed 8-bit	17
Uncompressed 10-bit	18
Mixing and Matching Formats in Final Cut	18

Chapter 3: Installation

Installation Overview	19
Unpacking	20
Shipping Box Contents	20

Installing the KONA LSe Card	21
Installing the KONA LS Card	23
Cabling the System	25
System Video/Audio Cable Connections	25
KONA LSe System Cabling When Using The Breakout Cable	26
KONA LS System Cabling When Using The Breakout Cable	27
Typical System	27
Installing KONA LS Software	28
Software Installation Procedure	29
Genlock and Your System	34

Chapter 4: Final Cut Pro and Other Application Software

Final Cut Pro	35
Using The KONA LS Control Panel	35
Control Panel Basics	36
Input Screen	38
Input Screen Settings	39
Proc Amp Screen	40
Formats Screen	41
Format Screen Settings	41
Analog Out Screen	42
Analog Out Screen Settings	42
Control Screen	43
Control Screen Settings	43
Setup Screen	45
Setup Screen Settings	45
Codec Screen	46
Codec Screen Settings	46
Timecode Screen	47
Timecode Screen Settings	47
Info Screen	48
Saving Your Control Panel Presets	49
Easy Setups for Typical Uses	49
Easy Setups Menu	49
Easy Setups For Use With KONA LS	51
Audio/Video Settings Menu	51
To Create A New Easy Setup	52
The Sequence Presets Window	53
Checking the System with a Simple Test Project of Bars and Tone	60
Using 8-bit Versus 10-bit Video	63

Chapter 5: Troubleshooting

If You Run Into Problems	65
Updating Software	66
Support	66
Apple Resources	67

Appendix A: Specifications

Index

Chapter 1: Introduction



KONA LS



KONA LSe

Overview

AJA KONA LSe and LS bring the highest quality SD and analog video/audio to a Power Mac running Final Cut Pro software. (For readability this manual refers throughout to the LSe and LS as “LS”.) KONA LS analog interfaces are very high quality. Using superb 12 bit video A/D and D/A converters, analog formats like BetaCam SP look excellent. KONA LS supports 8 and 10 bit uncompressed video, DV25 and DV50 using the DVCPRO codec, and JPEG—all on an Apple Power Mac G4/G5. In addition to high quality video, KONA LS also supports balanced analog, AES/EBU, and embedded audio I/O, all at 24 bits and 48Khz. For simplified system integration, KONA LS includes hardware sample-rate conversion for AES inputs (eliminating annoying synchronization hassles)—and RS-422 machine control.

LSe and LS Models

The KONA LSe and LS models both provide the same power and functionality, but differ in their bus interfaces. The KONA LSe offers a PCI Express interface for use with the latest Apple Power Macs (G5 PCIe models). The KONA LS is a PCI card that plugs into a G4 or G5 chassis (G5 PCI and PCI-X models). Both models work with Final Cut Pro and other applications to provide a professional editing suite, corporate/industrial video center, or high-powered desktop video setup. And for even easier connectivity, an optional KL-Box rack mountable breakout box can be purchased for either model—it ships with its own cable set (please ensure you buy the correct box for your model since the cables to the KL-Box differ between the LS and LSe).

KONA LS/LSe work with Final Cut Pro and other applications to provide a professional editing suite, corporate/industrial video center, or high-powered desktop video setup.

This manual covers the installation and operation of both the KONA LSe and LS and discuss using them with Final Cut Pro and other applications. Instructions for installing the KL-Box are shipped separately with it.

Features

The KONA LS card offers a large number of unique features for optimum quality, ease of use, and support for a wide variety of workflows and environments.

Hardware

- 12 bit accuracy Component/Composite/S-video analog I/O
- SDI input, two SDI outputs
- AES I/O; sample rate conversion on input (2 Channels, XLRs)
- Balanced analog audio I/O (2 Channel XLR)
- 6-Channel SDI embedded audio support
- Genlock
- RS-422 Control Port (Sony), 9-pin D, for machine control
- 64 bit, 66MHz universal PCI card
- Breakout cable
- Optional KL-box Breakout Box—Provides Rack mounting and Flexible Easy I/O (2 KL-box cables are included with the KL-box)
- Available for PCIe G5s as KONA LSe
- Available for PCI G4 and G5 as KONA LS

KONA LS Audio

KONA LS supports 2-channel 24-bit 48kHz AES audio via XLR connections, and 6 channel embedded 24 bit 48kHz audio over the same single SDI connection as the video. If you are using a digital VTR—you'll have the proper connections.

For analog audio, KONA LS provides two-channel balanced audio input and output. If you purchase the optional KL-Box breakout box, you also get two-channel unbalanced audio output (RCA jacks).

At the present time Final Cut Pro only supports 2 channels of audio input and up to 24 channels of audio output. However, KONA LS supports 6 audio channels in and out via the hardware, and will support multichannel audio input when Final Cut Pro supports that function in the future. KONA LS also features AES input sample rate conversion; this feature eliminates the requirement for audio source synchronization. Sample rate converters auto-lock to any AES input, 32-48KHz, and then convert it to 24 bit 48KHz audio, perfectly locked to internal KONA LS video. Sample rate conversion is done at very high quality (over 120db THD).

Software

- KONA LS Control Panel for source selection and controlling KONA LS within the overall MacOS environment (Macintosh Desktop, Input Pass through, and more).
- AJA QuickTime™ Drivers for tightly integrated hardware/software operation.
- Supports all popular standard definition formats: 8/10 bit uncompressed, JPEG, DV25/50, and 3:2 pulldown for 24Hz support.
- Support for Apple Final Cut Pro™ (application software not included).
- Support for After Effects, Combustion, Motion, and Other Applications (application software not included).

AJA's KONA LS software and hardware were developed for use with Final Cut Pro for powerful integrated video/audio capture, editing, and video production. With an Apple G4 (LS-only) or G5 (PCIe for LSe or PCI for LS), FCP, and KONA LS, you have an ideal high-quality cost-effective system for standard definition and analog video production. Software is supplied on CD, including the KONA Control Panel, drivers for the card itself, and all files necessary for Final Cut Pro and other application support (Final Cut Pro software application not included).

What's In The Box?

When you unpack your AJA KONA LS, you'll find the following components:

- AJA KONA LS Software and Documentation CD-ROM—this CD contains the software installer to place KONA LS drivers and the Control Panel on an Apple Power Mac. Install the software as discussed in this manual in *Chapter 3: Installation and Configuration*. The CD also contains a wide variety of useful information, including this manual you're reading (PDF format).
- KONA LSe or LS PCI card.
- Cable, KONA LSe Standard Breakout or KONA LS Standard Breakout.

- Read Me First Notice—Contains late-breaking news and/or errata related to KONA LS and the documentation.
- Registration Sheet—allows you to register your card by mail or online (details provided).

Please save all packaging for shipping the KONA LS should you wish to do so when moving or sending it in for service.

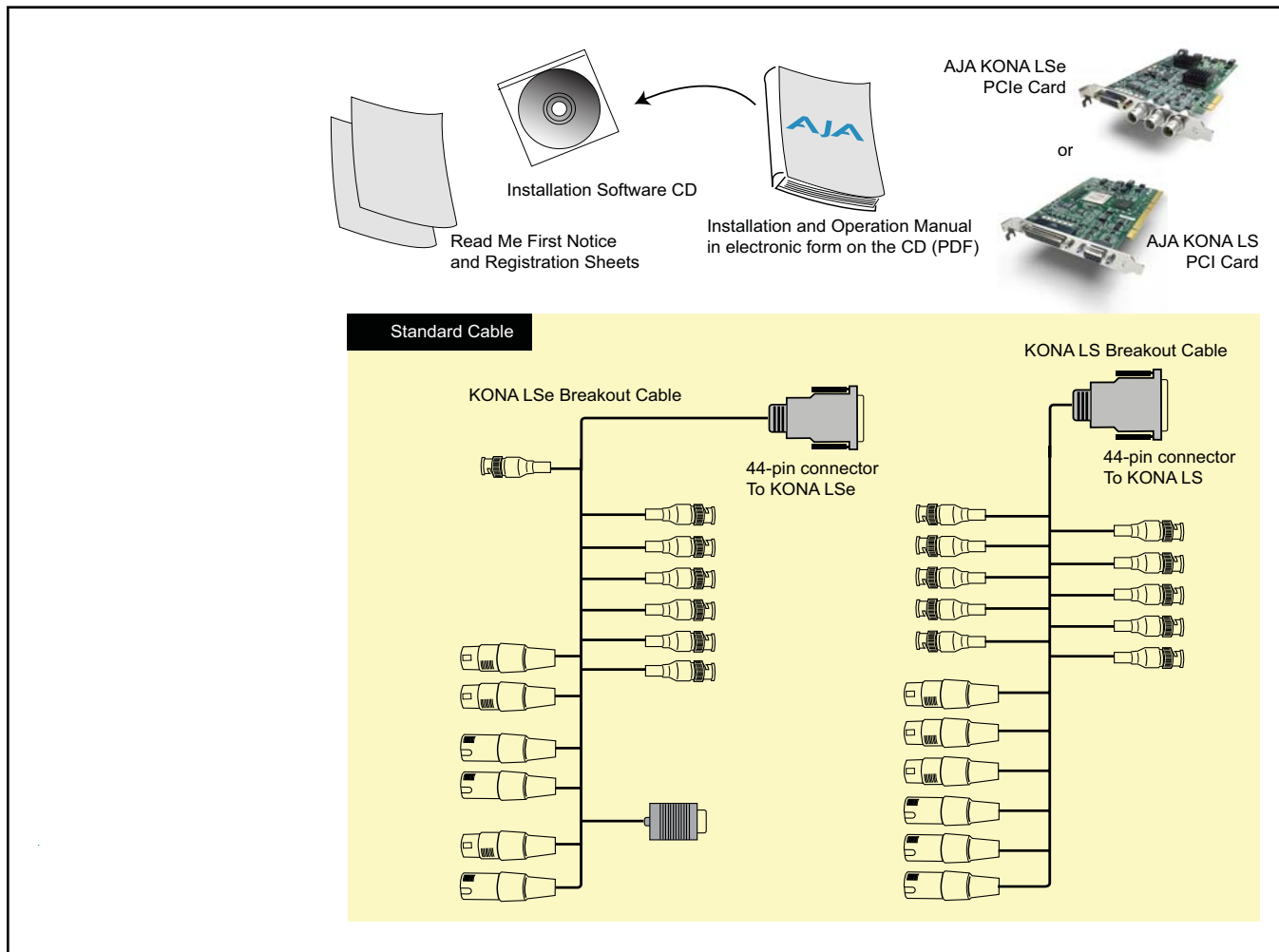

KONA LS Shipping Box Contents

System Requirements

AJA Video recommends that your system meet minimum hardware and software requirements to achieve a satisfactory level of performance when operating it. Here, we provide minimum and recommended requirements and then discuss disk storage issues that should be understood for proper system configuration.

Minimum and Recommended System and Software Requirements

The following table outlines the system hardware and software needed.

Item	Minimum	Recommended
Macintosh Operating System	OS X, version 10.4, QuickTime 7	OS X latest release. QuickTime 7 or Latest
Editing/Production Software Suite	Final Cut Pro 5	Final Cut Pro Studio
Macintosh	<p>Model KONA LS Minimum: Power Mac G4, 800 MHz with Minimum 512 MB RAM</p> <p>Model KONA LSe Minimum: Power Mac G5 (dual) PCI-Express 2GHz with 1GB or more RAM</p>	<p>Model KONA LS Recommended: Power Mac G5 (dual) with 1GB or more RAM</p> <p>Model KONA LSe Recommended: Power Mac G5 PCI-Express (dual) 2.3 GHz or Quad 2.5GHz with 1GB or more RAM</p>
Internal Storage (inside Mac) For DV only; uncompressed SD requires external RAID.	SATA (1 internal HD)	SATA (2 internal HDs RAIDed)
RAID Interface	Fibre Channel or SCSI	Fibre Channel or SCSI
Disk Storage Note: see Storage Methods topic that follows later in this Chapter	4 SCSI Hard Drives External RAID	Apple Xserve RAID

Understanding Disk Storage Methods

The KONA LS card, an Apple Power Mac, and Final Cut Pro, together offer an unprecedented level of features and performance for all Video/Audio production applications. However, to ensure performance and quality, the disk storage system used with the Apple Power Mac must be able to meet the demands of storing realtime uncompressed media. At the very minimum, the disk storage system must be able to provide and maintain a consistent 50 MB/s transfer rate from the Power Mac to disk (read/write). There are a variety of system configurations and peripherals that can provide this level of performance. Possible system configurations are listed following:

Storage Method	Features/Limitations	Cost
Xserve RAID	Features up to 14 ATA/100 drive channels, dual independent RAID controllers, and a dual 2Gb Fibre Channel host interface. Xserve provides up to 5.6TB of storage with throughput of up to 400 megabytes per second.	Expensive, although the cost per gigabyte is excellent when large storage is needed
External ATA/IDE or SCSI RAID	Scalable. Performance almost as good as Xserve, although it can be more complex to set up and maintain. Many vendors offer solutions (too many to list here; check with your Apple dealer for SCSI Storage solutions for details). Although the connection to the external RAID chassis is SCSI, the drives themselves may be SCSI or ATA. A pure SCSI array will offer higher performance at a higher cost.	Moderately Expensive

Note: LSe Requires a PCI-Express Macintosh
 LS Requires a PCI Macintosh

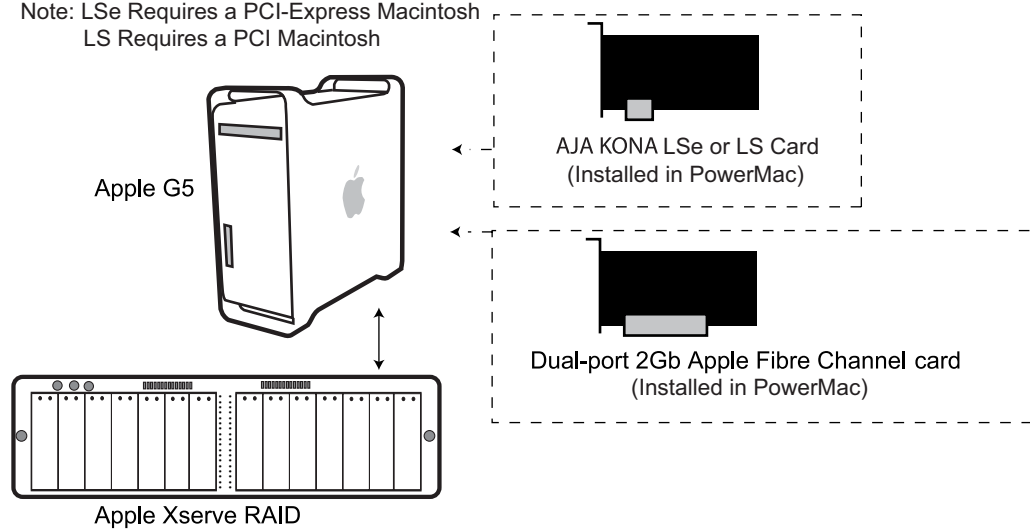

Disk Storage Solutions—G5 With Xserve RAID

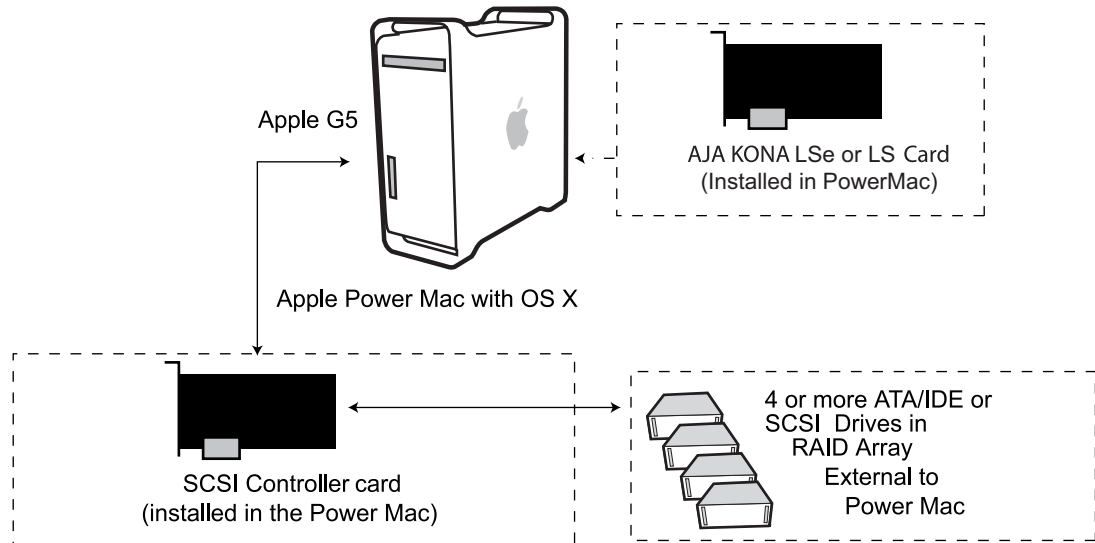

Disk Storage Solutions—External ATA/IDE or SCSI RAID

About RAIDs

Redundant Array of Independent Disks, or RAID, is a group of hard drives that appears to the host Power Mac as a single high-speed storage unit. RAID systems enable you to increase storage capacity and get the performance, reliability, and data protection needed for video production, but not possible from a single hard drive. RAID drives inside the array operate simultaneously, increasing overall throughput. RAID technology is comprised of these techniques (some or all):

- Striping data across multiple drives for storage performance (RAID 0).
- Mirroring for redundancy (RAID 1).
- Parity for data protection (RAID 5 [plus others]).

Most RAID configurations, or RAID levels, combine these to provide a balance of protection and performance.

Striping divides a logical drive into data blocks, or stripes, that are distributed across an array of physical drives. Striping a set of disks improves storage performance because each drive operates concurrently. However, striping alone, known as RAID level 0, offers no data protection.

Mirroring involves writing identical copies of all data to a pair of physical drives. This results in very high data reliability: If one drive fails, the data is still available on the remaining disk drive. However, it also results in a storage efficiency of only 50 percent, because two physical drives are required to achieve a single drive's capacity. Mirroring alone is known as RAID level 1.

Parity provides data protection without requiring complete duplication of the drive contents. In the event of a drive failure, parity information can be used with data on surviving drives to reconstruct the contents of a failed drive. Parity data can be stored on a dedicated drive, as in RAID 3, or distributed across an array of drives, as in RAID 5. Parity provides much greater storage efficiency than mirroring—up to 85 percent for a set of seven drives.

Software For Striping

AJA recommends the Disk Utility software provided by Apple with OS X for creating and striping RAIDs, including 3rd-party, SCSI, and Xserve RAIDs. It is very easy to use and has been tested to work well. The utility can be found in *Macintosh HD/Applications/Utilities*, where “*Macintosh HD*” is the name of the system drive.

AJA KONA LS and Xserve RAID

For the optimum in disk storage with Final Cut Pro and AJA KONA LS, we recommend Apple’s Xserve RAID. Xserve RAID holds up to 14 hot-swap Apple Drive Modules—5.6TB of storage—in a rack-optimized 3U enclosure. Each 7200-RPM hard drive connects to a dedicated ATA/100 drive channel, eliminating a traditional source of bottlenecks and maximizing the 2Gb/s Fibre Channel host connection(s). By adding more Xserve RAID systems, you’ll have very large expansion capabilities: A standard 42U rack can hold over 78TB of Xserve RAID storage.

Xserve RAID is designed for nonstop operation. Redundant hot-swap power and cooling modules allow the system to keep functioning even if one module fails. A high-availability architecture and dual independent RAID controllers support RAID levels 0, 1, 3, 5, and 0+1. In addition, Xserve RAID supports hybrid RAID levels 10, 30, and 50 when used in conjunction with host-based software RAID. Remote Xserve RAID management capabilities are provided via Apple’s Java-based RAID Admin application.

Note: When creating and striping an Xserve RAID for KONA LS using the Apple Disk Utility provided with OS X, use *RAID 50*: in other words, the internal Xserve RAID drives are set up as RAID 5; the Xserve RAID then shows up in Disk Utility as two drives (regardless of the number of internal drives) which must be configured together as RAID 0. Apple calls this configuration “RAID 50.”

Storage capacity

No matter which storage system you choose, pick one that can scale to meet your needs over time. Ideally, you should be able to increase storage capacity or switch to a RAID level offering increased data protection in the future. Balance current and future storage needs with your budget and choose accordingly.

FORMAT	Transfer Rate in MB/sec	Storage Requirement in GB/Hour	Hours of Storage Per Terabyte of Disk
10 bit Uncompressed Standard Definition	28	101	9.9
8 bit Uncompressed Standard Definition	21	76	13.1
DV50 Standard Definition	6.3	23	43.4
DV25 Standard Definition	3.1	11	90.0
Photo JPEG Standard Definition	2.5	9	111

MB = MegaBytes
GB = GigaBytes

Note: for uncompressed formats, PAL and NTSC transfer rates and storage requirements are the about the same because PAL has a lower frame rate, but more lines.

Cable Connections

When KONA LSe or LS is installed in a PowerMac, it connects to the outside world via either the standard breakout cable supplied, or the optional KL-box (using the two cables supplied with it). Although the LSe and LS are functionally identical, they do have different bus interfaces (LSe is PCIe and LS is PCI) and cable connections.

Using the Standard Cables

KONA LSe/LS comes with complete cable connectivity for your video/audio system connections. Simply plug in the supplied breakout cable to the 44-pin connector on the card.

KONA LSe breakout cable supports:

- Reference Input (BNC)
- Component/Composite/S Video Input (3x BNC)
- Component/Composite/S Video Output (3x BNC)
- AES In (2x XLR)
- AES Out (2x XLR)
- Balanced Audio In (2x XLR)
- Balanced Audio Out (2x XLR)
- RS-422 Machine Control (9 pin D)

The three BNCs on the KONA LSe Card endplate additionally provide:

- Standard-definition SDI input (BNC)
- 2 SDI outputs (2x BNC, independent outputs)

KONA LS breakout cable supports:

- SDI input (BNC)
- 2 SDI outputs (2x BNC, independent outputs)
- Reference Input (BNC)
- Component/Composite/S Video Input (3x BNC)
- Component/Composite/S Video Output (3x BNC)
- AES In (1x XLR)
- AES Out (1x XLR)
- Balanced Audio In (2x XLR)
- Balanced Audio Out (2x XLR)

For VTR machine control, connect a 9-pin RS-422 cable directly to the 9-pin connector on the KONA LS card end-plate.

**KONA LSe
Cable**

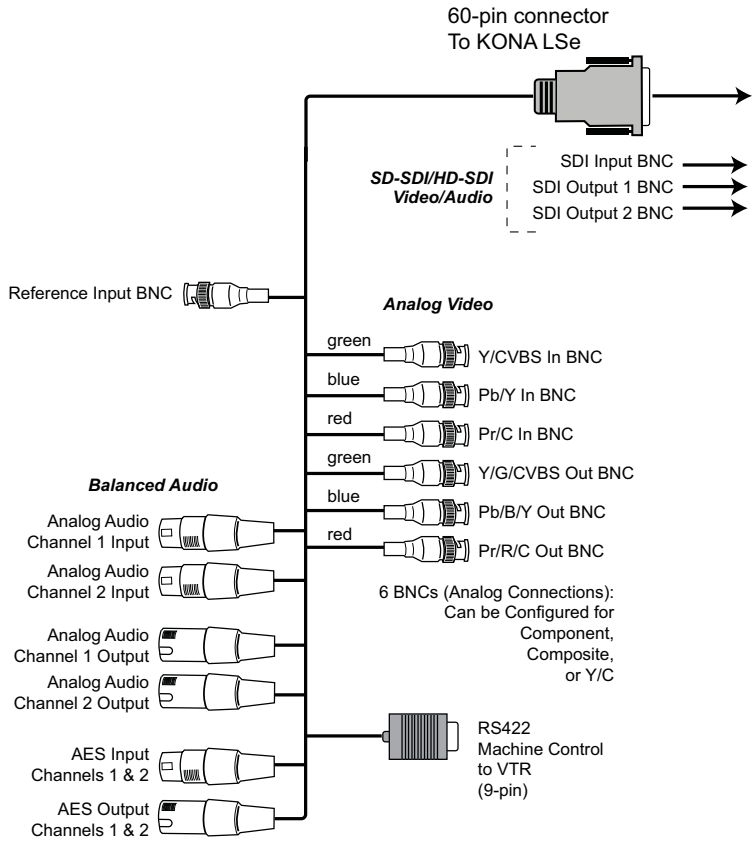

**KONA LS
Cable**

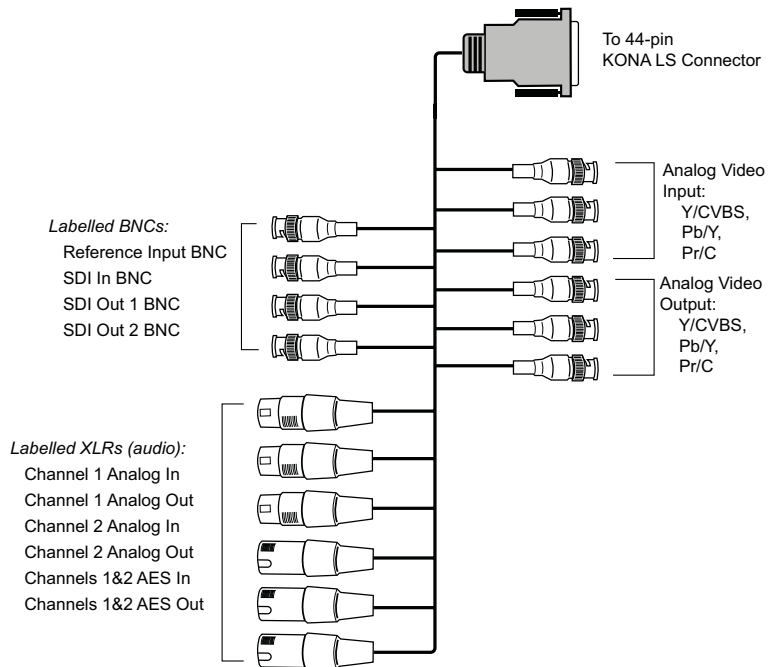

KONA LSe and KONA LS Breakout Cables

Using KL-box

The KL-box attaches to the KONA LSe or LS card via cables that attach to the back of the KL-box. These cables and installation instructions are supplied with the KL-Box.

Note: The LSe and LS use different cables to attach to the KL-Box; ensure you have ordered the correct KL-Box for your model.

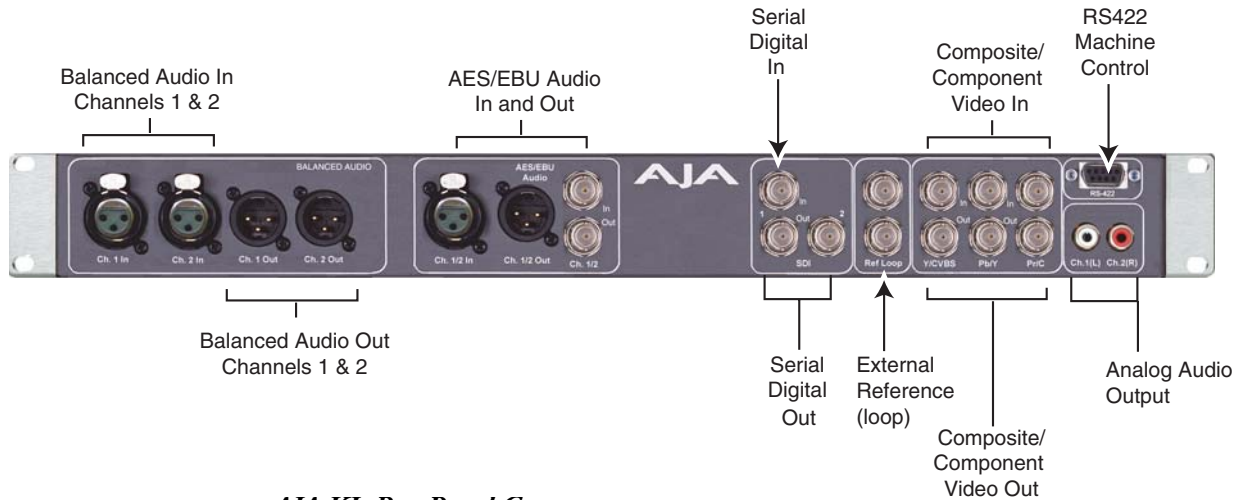

AJA KL-Box Panel Connectors

About BNC Connectors

Although most video professionals are used to BNC connectors, you may not have seen them if you've been using primarily desktop video equipment. BNC connectors ensure a positive connection by the act of locking the connectors together via pins in one connector that fit into slots in the corresponding connector.

To make a BNC connection, slide the cable connector over the panel connector and then when seated, rotate the barrel of the cable connector 90° clockwise until the connectors are locked together. When properly locked, the cable cannot accidentally be pulled out.

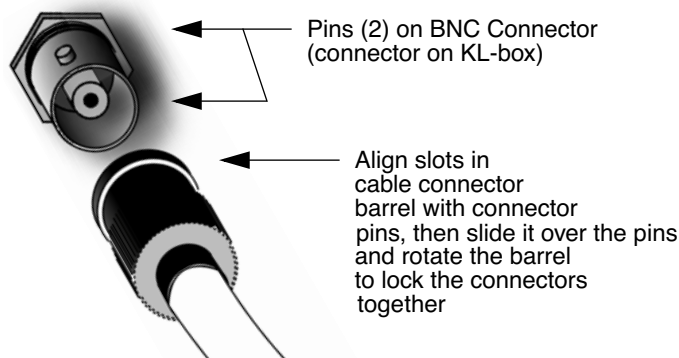

Connector Descriptions—Cables and KL-box

Connectors on the standard cable set are labelled as to their function for easy installation and maintenance. Similarly, connectors on the optional KL-box are also labelled.

2 Channel Digital AES/EBU Audio Inputs And Outputs

One female XLR connector is provided for the channel 1 and 2 inputs, while a male XLR connector carries channel 1 and 2 outputs. AES/EBU signals are handled internally as 24-bit digital. The optional KL-box also provides XLR audio connections on the front panel.

Note: These XLR connections are digital and cannot be used with analog equipment having XLR connectors.

Analog 2 Channel Balanced Audio

Two sets of analog XLR connectors, one for each channel, support balanced audio connections. Male XLRs are provided for outputs and female XLRs are provided for inputs. Balanced audio (differential) connections provide better analog audio quality over longer cable runs. Most professional quality VTRs and audio equipment have XLR style connectors for analog audio. Analog audio signals are converted internally to 24-bit digital.

Analog 2 Channel Unbalanced Audio (KL-box only)

On the KL-box are two analog output connectors, one for each channel. These connectors are RCA-style phono jacks.

RS422 Machine Control

A female DB9 connector provides connection for VTRs, camcorders, disk media servers, and other devices using RS422 SMPTE (Sony) protocol. This connector is present on KONA LS card endplate and on the optional KL-box—either can be used similarly. On the KONA LSe, this connector is on the breakout cable. Connector pinout is listed in Appendix A: Specifications.

SDI Input and Outputs

BNC connectors are provided for one SDI input and two SDI outputs (independent of the input). SDI inputs and outputs support video and embedded 24-bit digital audio. Use SDI wherever possible for the best quality 10-bit uncompressed video input, capture and output. If peripheral equipment has a variety of inputs/outputs, look to see if it has SDI I/O, and use it where possible. Most high-end professional broadcast equipment supports SDI (VTRs, cameras, media storage servers, etc.). On the KONA LSe these connectors are on the card endplate. On the KONA LS, these connectors are on the breakout cable.

Analog Monitor Out (Component/Composite SD)

Both the standard I/O cable and the optional KL-Box feature two groups of 3 BNC connectors (each) for input and output of component, composite and Y/C functions. The signals are labelled on both the cable and KL-Box connectors.

Component video signals are generally higher quality than composite, but not as high quality as serial digital (SDI).

A Note About RGB—Although RGB is used less in today’s video systems, KONA LS supports it (RGB out only). However, because KONA LS (and SMPTE SDI) native format is YPbPr, AJA recommends the use of YPbPr whenever possible for analog monitoring. Although component video monitors often have RGB inputs, it’s better to use YPbPr when the monitor supports it. The YPbPr format provides “headroom” for “superwhite” and “superblack”—and these video levels *will be clipped* when transcoding to RGB. Also, the RGB/YPbPr transcoding involves a level translation that results in mathematical round-off error. RGB can be configured in the KONA LS Control Panel.

A Note About YPbPr—Component Video, or YPbPr, has been given several names over time. YUV, Y/R-Y/B-Y, and YCbCr, are just some examples. Although these various formats have some differences in levels, they are all basically the same. KONA LS uses the modern YPbPr terminology exclusively. KONA LS supports three different types of YPbPr: SMPTE/EBU N10, Betacam (NTSC), and Betacam (NTSC Japan). These three formats differ in level only and are configured in the KONA LS Control Panel.

Reference Video

A single BNC on the standard KONA LS cable—or two BNC connectors on KL-box (it loops through)—allows you to synchronize KONA LS outputs to your house analog reference video signal (or black burst). If you have a sync generator or central piece of video equipment to use for synchronizing other video equipment in your studio, then connect its analog composite output here. When KONA LS outputs video it uses this reference signal to lock to. When connecting a reference video source, the locking signal should be the same format as the Primary format selected in the KONA LS Control Panel. It is possible in some circumstances to use an alternate format video signal as long as the basic frame rate is compatible.

In This Manual

Chapter 1 is the introduction you’re reading, listing features, box contents, and system requirements.

Chapter 2 gets you started with using KONA LS in a typical Video environment. Typical workflows are discussed.

Chapter 3 provides complete instructions for installing and configuring the AJA KONA LS card. The user is guided through unpacking, installing the card into a PowerMac, installing KONA LS Mac Software From CD, cabling the system and then getting it up and running. Important configuration information is also provided on video settings and use of genlock/external reference.

Chapter 4 discusses operational aspects of KONA LS when used with Final Cut Pro.

Chapter 5 discusses troubleshooting problems with your system and what to do when there’s a problem you can’t solve.

Appendix A presents a list of technical specifications for the product.

Appendix B gives a glossary of technical terms and acronyms used in the manual.

The remainder of the manual consists of appendices listing specifications and an index section to help you rapidly find topics in the manual.

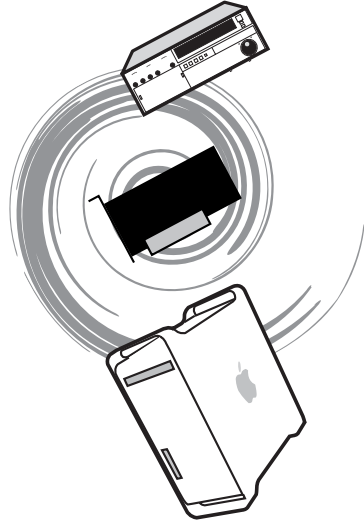

Chapter 2: Getting Started



KONA LS And Your Workflow

There are a lot of ways to think about the video/audio workflow you follow. Your setup might be categorized as corporate video, professional broadcast, or desktop video. Or the workflow might be categorized by the type of equipment used rather than the nature of work produced—many systems these days are a mixture of equipment from high-end professional to desktop video. This chapter hopes to show how Final Cut Pro and KONA LS can help fit into whatever workflow you currently have and make it more efficient.

A *Workflow Scenarios* diagram on the following page shows types of equipment, sorted by VTR source, and the types of workflow attributes and KONA LS applications supported. After the diagram, we also discuss some typical applications.

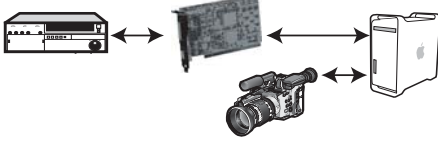
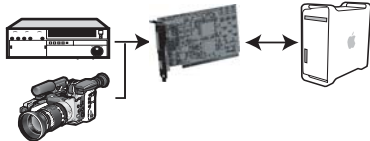
Source Deck Type(s)		Workflow Attributes	Applications
Digital SD Examples: Digibeta, DV50, DVCPRO and DVcam		KONA LS captures and outputs SD video with embedded audio. Use high-quality AES/EBU and/or embedded 8-channel audio output.	Pro Broadcast Corporate/Industrial On-site Editing
Analog Example: Beta		KONA LS captures and outputs Y/C, Component, and Composite Video, with 2-channel audio.	Corporate/Industrial Pro Broadcast On-site Editing
Digital capture via Firewire with Output via AJA KONA LS Example: MiniDV		Using standard desktop video techniques, video/audio is captured directly from a camcorder or deck. KONA LS is used for playing back captured media and editing/mastering to tape or DVD using Final Cut 4.5HD and other tools such as After Effects, Combustion, Apple Motion, etc.	Desktop Video Corporate/Industrial On-site Editing Pro Broadcast
Without even using a deck; use the video monitor as a second Mac monitor. The KONA LS desktop lets you drag graphics from programs like Adobe Photoshop from the computer display to the video monitor. You paint full frame and live onto a broadcast monitor. Output virtually anything to video—ideal for animators and compositors.		Using Final Cut Pro, work with a wide range of old and new SD and analog sources, and then also using desktop graphics and video software for creative power and flexibility.	Post-production Animation Compositing

Workflow Scenarios

Understanding Typical Workflows

KONA LS and Final Cut Pro 4 allow more workflow flexibility than ever before. Users can independently select different formats for capture and storage media, while also outputting to an array of analog and digital uncompressed formats—with all outputs active simultaneously. Capture can range from DV to analog, or digital uncompressed. Media can be stored on disk as:

- offline quality at low bit rates
- on-line quality at moderate bit rates
- or with the highest quality as 8 or 10 bit uncompressed

Following are summaries of the most common workflows, listing data rates and relative quality levels. Some workflows require a RAID array and some will work using the host Power Mac's internal system drive—it's noted where this is supported in the following discussions.

PhotoJPEG

Data rate: approximately 1-3 MB/second—supported by internal system drive

Quality: Very Good

The Apple PhotoJPEG codec offers an excellent compressed media choice for on-line quality at low data rates. PhotoJPEG can use the full-raster at 4:2:2 sampling. Final Cut Pro allows you to adjust quality using a PhotoJPEG control panel. KONA LS allows for PhotoJPEG monitoring and/or output in SD. KONA LS can capture from almost any input, directly to PhotoJPEG media.

DV (DV25)

Data rate: 3.13 MB/second (megabyte/second)—supported by internal system drive

Quality: Good

In this workflow, DV is usually input to a Power Mac running Final Cut Pro through its FireWire port. DV offers good quality, but it has lower Chroma resolution when compared to DV50, JPEG, or uncompressed. You can use KONA LS to playback DV projects to uncompressed—in real time—for monitoring and/or output. Alternatively, KONA LS can capture uncompressed from any input, directly to DV clips.

DV50

Data rate: 6.26 MB/second—supported by internal system drive

Quality: Very Good

Like DV25, Final Cut Pro also supports the Panasonic DV50 standard definition codec. DV50 is a 4:2:2 compressed format and therefore has higher chroma resolution when compared to DV25. Also like DV25, you can use KONA LS to playback DV50 projects to uncompressed—in real time—for monitoring and/or output. KONA LS can capture uncompressed from any input, directly to DV50 clips.

**Uncompressed
8-bit**

Data rate: 21 MB/second (see later “Storage Capacity” chart in Chapter 1 for transfer rates)—requires SCSI, Fibre Channel, or ATA drive array

Quality: Excellent

Uncompressed media is KONA LS’s native storage format, offering the highest quality available. Capturing in uncompressed results in no compression artifacts, and video is sampled over the full raster at a 4:2:2 rate. Using uncompressed maintains a higher quality in your project from capture all the way through effects rendering. Final Cut Pro supports realtime effects with uncompressed media using RT Extreme. KONA LS supports capture of uncompressed through any of its inputs, and projects are output to all of its outputs simultaneously.

Uncompressed 10-bit

Data rate: 28 MB/second (see later “Storage Capacity” chart in Chapter 1 for transfer rates)—requires SCSI, Fibre Channel or ATA drive array

Quality: Excellent, very high quality

Offering all the benefits noted previously for 8-bit uncompressed, 10-bit additionally offers the very highest quality available. With 10-bit media and Final Cut Pro’s 32 bit Floating Point YUV effects rendering, video quality is second to none—at any price. For more information on this subject, please see the topic at the end of Chapter 4: *Installation and Configuration*, titled “Using 8-bit Versus 10-bit Video.”

Mixing and Matching Formats in Final Cut

In Final Cut Pro, it works best to use one format consistently. For example, if you capture DV 50 files and then capture 8-bit uncompressed files, you’ll have to convert one or the other when using the two types on the same Final Cut *sequence* (the timeline where media is edited into a project). You could even capture 8-bit uncompressed and DV, and then place them both on a PhotoJPEG timeline and end up having to render them *both*. You can capture directly, in real time to any supported format, even if it doesn’t match the source formats at all (for example, DV and DV50 to 8 bit uncompressed).

Therefore, it makes sense to capture media into your system at the highest quality you’ll expect to use to eliminate re-rendering and ensure best results. KONA LS is ideal for this since it has the connections necessary to bring in a variety of sources and formats for capturing into Final Cut.

Chapter 3: Installation & Configuration



Installation Overview

The installation and set up of a KONA LSe/LS is very simple. All of the steps of installation and configuration are documented in this chapter, summarized as follows:

1. Unpack the shipping box
2. If not previously installed on your Power Mac, ensure that Final Cut Pro is installed as detailed in its user documentation. Final Cut Pro *must be installed and have been run at least once prior to installing AJA KONA LS software.*
3. For Model LSe:
Lay the PCI PowerMac G5 on it's on it's side (motherboard facing up). Install the KONA LSe capture card into one of the PCI Express slots in the PowerMac. The RAID controller card (SCSI or Fibre Channel) can go in any other available slot.

For Model KONA LS:

Lay the PCI PowerMac G4 or G5 on it's side (motherboard facing up). If a G5 with PCI-X slots, install the KONA LS capture card into one of the 100 MHz slots in the PowerMac and put your RAID controller card (SCSI or Fibre Channel) in the PCI-X 133 MHz slot. If another type of G5, or a G4, then install capture card into any available PCI slot.

4. Install AJA KONA LS software on your Power Mac from the supplied AJA CD-ROM
5. Cable the system audio and video sources, VTR, audio monitor, and video monitor. If you purchased the optional KL-box, then install it into an equipment rack or place it on a desk and connect its two cables to the KONA LS card. If you're instead using the standard cable set, then use those to connect equipment.

Each of these steps are explained in greater detail in the remaining pages of this chapter.

Unpacking

Shipping Box Contents

KONA LS is shipped with a CD containing system software and an Installation and User manual (a PDF on the CD), and a cable. If you purchased the optional KL-box breakout box, it ships with its own set of cables and instructions for connection to the KONA LS card.

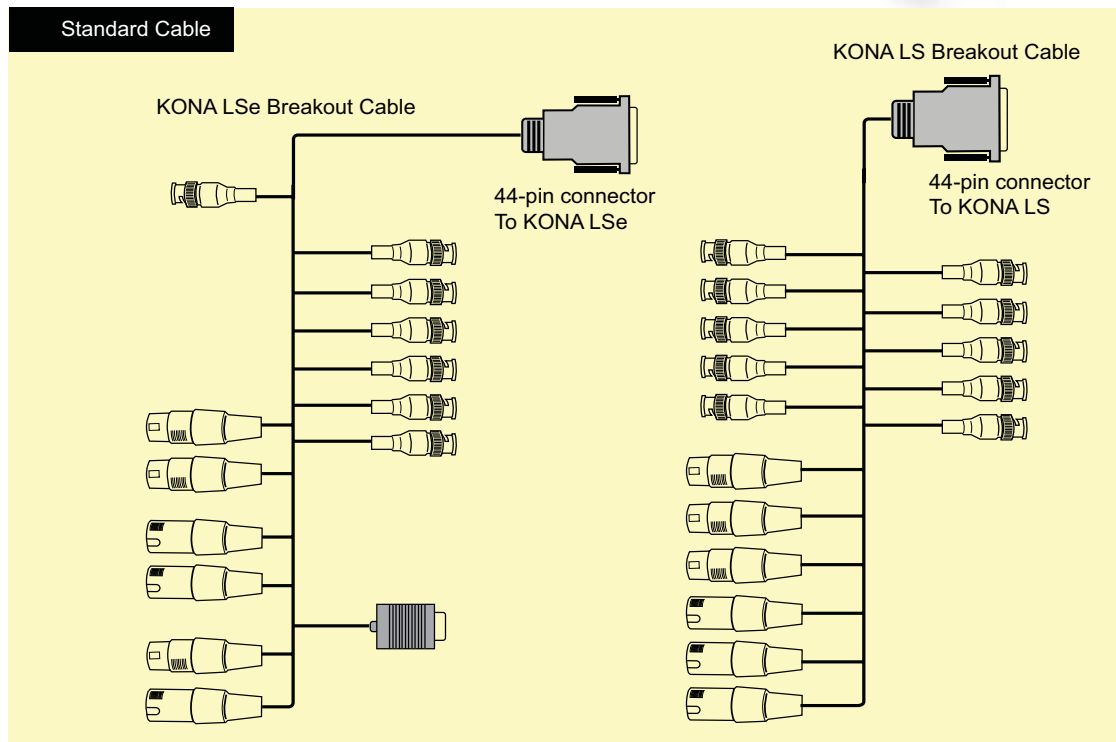
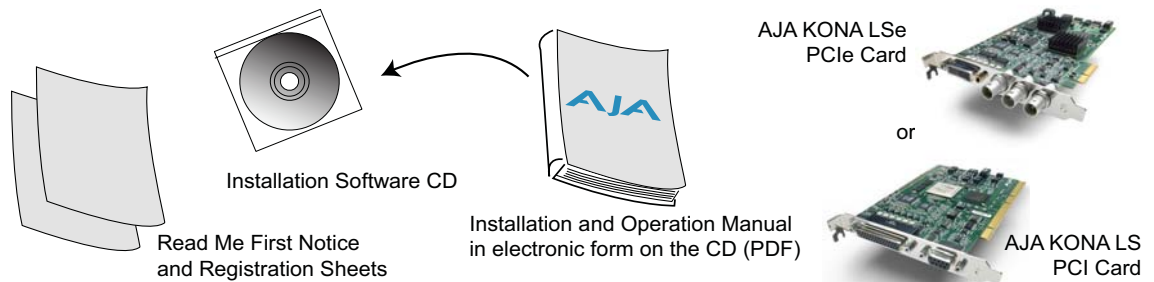

Contents, KONA LS Shipping Box and Optional KL-box Shipping Box

As you unpack the shipping box(es), carefully examine the contents. Ensure you received everything and that nothing was damaged during shipment. If you find any damage, immediately notify the shipping service and supply them with a complete description of the damage. AJA will repair or replace damaged items. If you find shipping damage, contact your AJA dealer or distributor for details on how to have your KONA LS repaired or replaced.

Note: Save packing materials and the shipping box. If you ever require service or move your system—use the packaging materials and box for safe shipment.

Installing the KONA LSe Card

1. Place the PCI-Express G5 in a well-lit convenient area, where you will have easy access to the chassis access door.
2. Using your hand, touch the outside of the G5 to discharge any static electricity you have. Remove the power cable from the back of the PowerMac G5.
3. Remove the access door and clear inner panel as described in your Apple G5 User Manual. Lay the G5 on its side, motherboard facing up.
4. Remove the KONA LSe card from its protective anti-static bag; place the card on top of the bag.
5. Visually locate the PCI-Express slots inside the G5 chassis (photo shown on the following page). The KONA card only requires a 4-lane PCI-Express slot, so any of the available slots will work correctly.
6. Remove the card edge access cover from the desired slot where you will be inserting the KONA LSe card. The card edge cover is secured by a phillips screw; save this screw for use in installing KONA LSe.
7. Holding the KONA LSe card by the card edge plate and an outside edge, carefully insert the KONA LSe card by rocking it slowly into the slot. Ensure the card edge aligns properly with the G5's opening (where the card edge cover was just removed) and that it is fully seated in the slot.
8. Secure the card in the slot using the screw removed earlier.
9. Replace the G5's clear inner panel and outer access door.



KONA LSe Card

To Install:

1. Remove Screw and Cover Plate and Insert KONA LSe Card
2. Secure KONA with Screw Removed Earlier

PCI-Express Slots

PowerMac G5 Cardcage Access

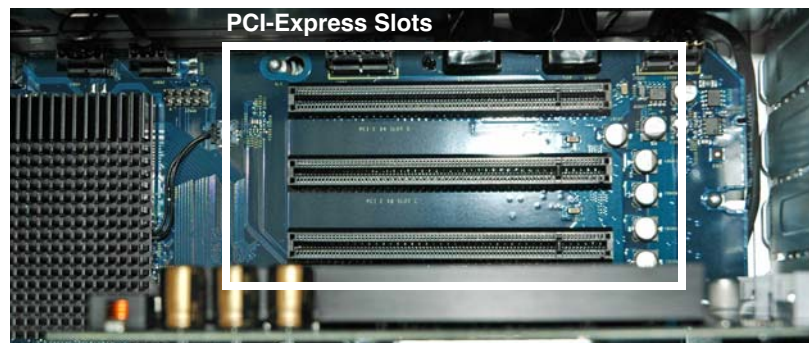

PowerMac G5, PCI-Express Slots: use any available slot for KONA LSe

Note: After you install the KONA LSe card, you may notice that in the MacOSX Network preferences there is a message stating “You have a new network port named KONA LSe —be sure to check the settings...”. There is no need to take any action; this occurs because MacOSX detects the RS-422 serial port on the KONA LSe card that you will use for VTR machine control.

Installing the KONA LS Card

1. Place the G4/G5 in a well-lit convenient area, where you will have easy access to the chassis access door.
2. Using your hand, touch the outside of the G4/G5 to discharge any static electricity you have. Remove the power cable from the back of the PowerMac.
3. Open the PowerMac to gain access to the card slots as described in your Apple User Manual. Lay the G4/G5 on its side, motherboard facing up.
4. Remove the KONA LS card from its protective anti-static bag; place the card on top of the bag.
5. If installing in a G5, install the KONA LS capture card into one of the 100 MHz slots in the PowerMac and put your RAID controller card (SCSI or Fibre Channel) in the PCI-X 133 MHz slot. Do not put the RAID controller *and the KONA LS* in the two 100MHz slots since this makes them share the same bus. If installing in a G4, put the KONA LS in any available PCI slot.

Note: On a G5, always put the RAID controller and KONA LS on separate PCI busses. This improves performance by reducing bus contention.

6. Remove the card edge access cover from the desired slot where you will be inserting the KONA LS card. The card edge cover is secured by a phillips screw; save this screw for use in installing KONA LS.
7. Holding the KONA LS card by the card edge plate and an outside edge, carefully insert the KONA LS card by rocking it slowly into the slot. Ensure the card edge aligns properly with the G4/G5's opening (where the card edge cover was just removed) and that it is fully seated in the slot.
8. Secure the card in the slot using the screw removed earlier.
9. Replace the PowerMacs panel/door as removed in step 3.



Remove the KONA LS Card From the Anti-Static Bag



Locate the PCI Slots Inside Your PowerMac (G5 Shown Here)

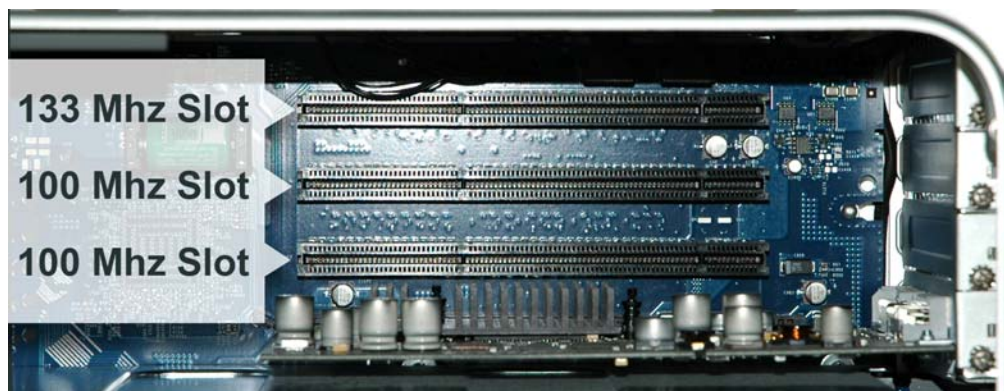

PowerMac G5 PCI Slot Detail

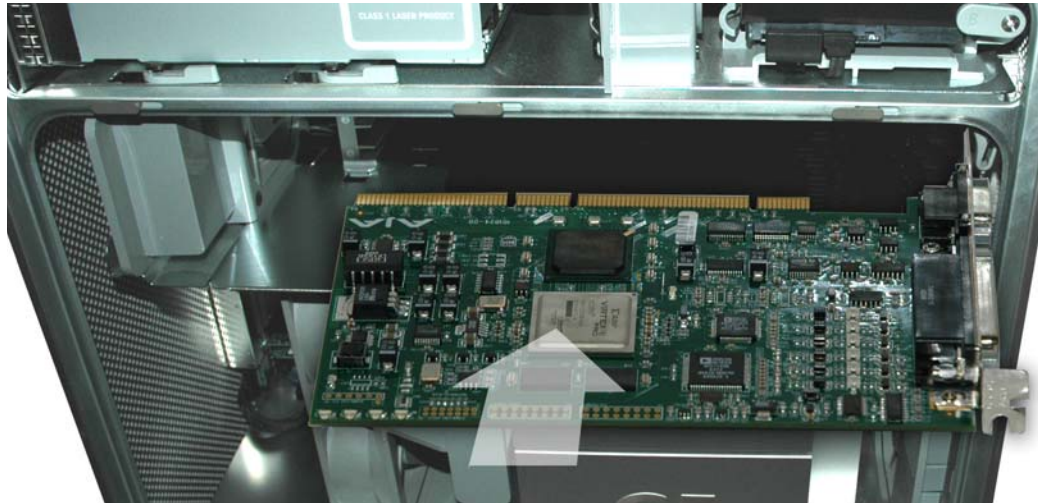

Insert the KONA LS Into the Slot

Note: After you install the KONA LS card, you may notice that in the MacOSX Network preferences there is a message stating “You have a new network port named KONA LS —be sure to check the settings...”. There is no need to take any action; this occurs because MacOSX detects the RS-422 serial port on the KONA LS card that you will use for VTR machine control.

Cabling the System

System Video/ Audio Cable Connections

When installing your system, you'll make video and audio input/output connections. These connectors are explained individually in chapter 2. Here, system interconnection is shown and described.

KONA LSe System Cabling When Using The Breakout Cable

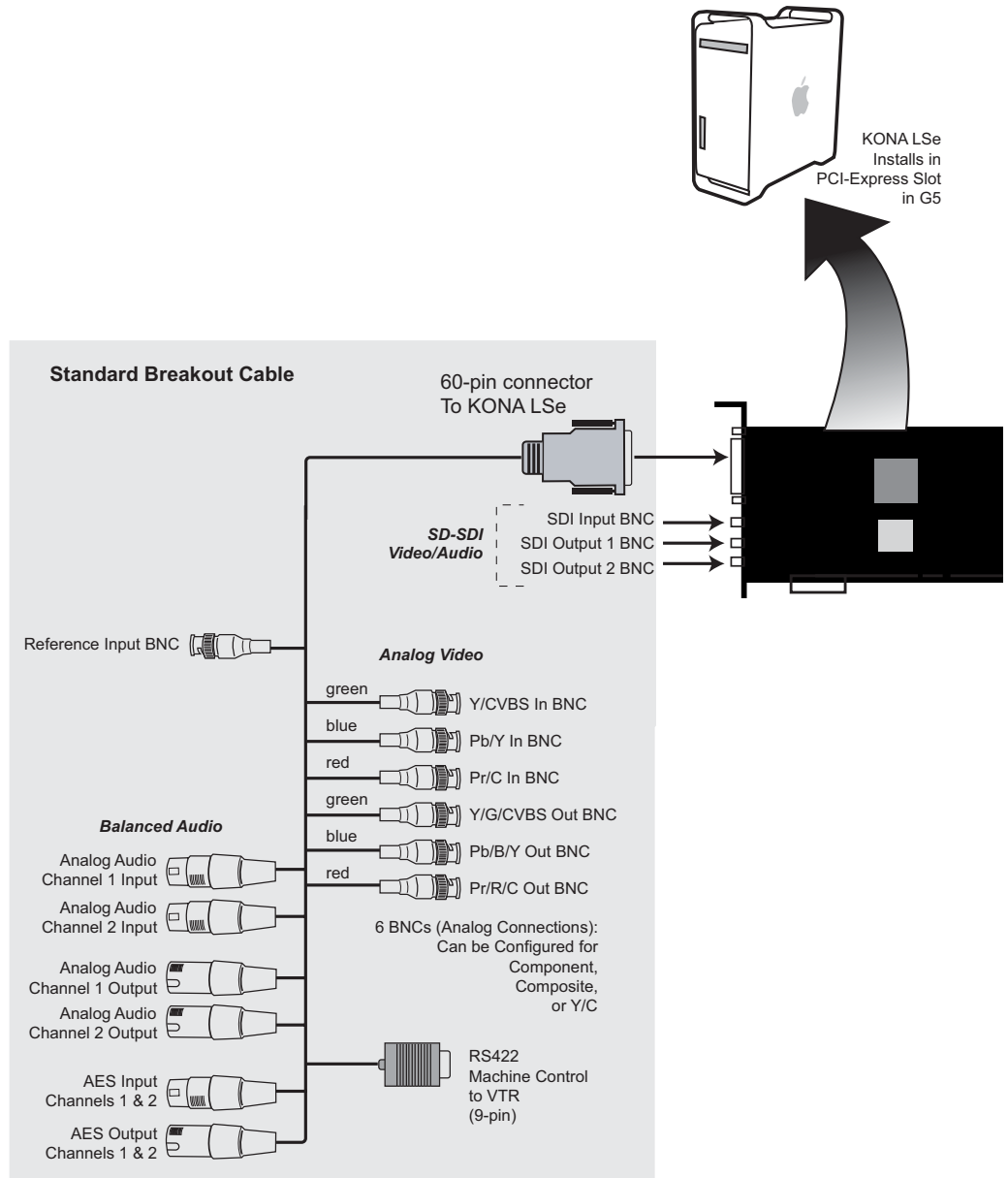

KONA LSe System Using The Breakout Cable

KONA LS System Cabling When Using The Breakout Cable

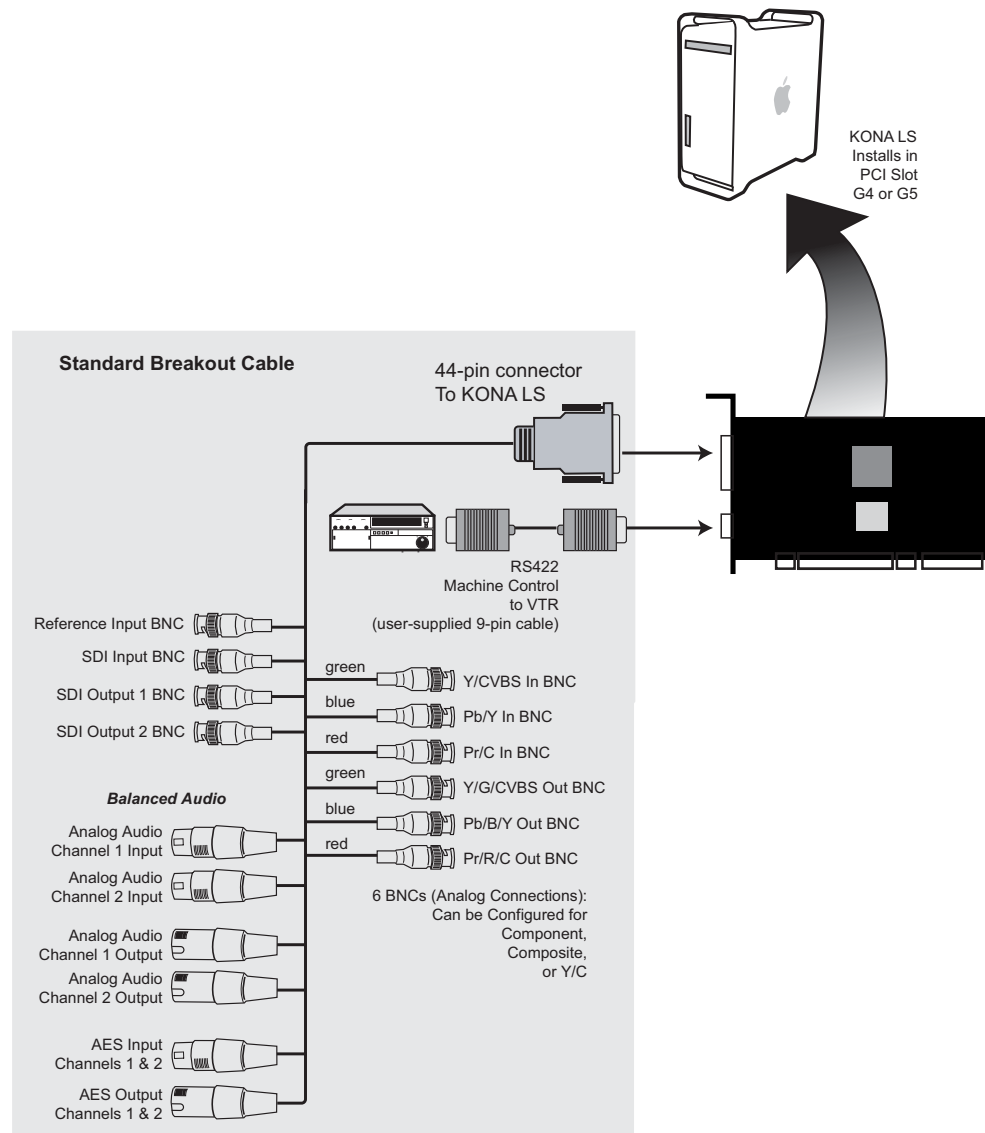

KONA LS System Using the Breakout Cable

Typical System

A figure on the following page shows typical system interconnections for a system with digital A/V sources. Your system may differ depending on VTRs, audio monitoring, and video monitoring.

1. If desired, connect your house reference sync to the KONA LS *Ref Loop* connector (BNC). The second KONA LS Ref Loop connector on the KL-box (if used) can be connected to your VTR or terminated with a 75 ohm terminator.
2. Connect a Video Monitor to the KONA LS *Component Analog Video Out* BNC connectors (preferred), or instead connect to a composite monitor.
3. Connect a 9-pin DB9 machine control cable between your VTR's RS422 control port and the KONA LS *RS-422* machine control connector. (On the

KONA LSe, this will be on breakout cable or KL-Box; on the KONA LS, it's on the circuit card endplate.)

4. Connect two SDI cables between KONA LS and your digital VTR (Digital Betacam etc.): one from KONA LS *SDI In* to the VTR *SDI Out*, and one from KONA LS *SDI Out* (1 or 2) to the VTR *SDI In*. The KONA LS SDI connections have embedded audio so the VTR must be configured accordingly. (On the LSe, the SDI connectors are on the card's endplate; on the LS they are provided on the breakout cable.)
5. If you have an AES/EBU-ready audio monitoring system, then connect the two channels of AES/EBU output from KONA LS's XLR connectors (channels 1 and 2) to the monitoring system AES/EBU inputs. If you instead have an analog audio monitoring system, you can use either the XLR balanced audio connectors or the two RCA-style unbalanced stereo output jacks on the Optional KL-box for output.

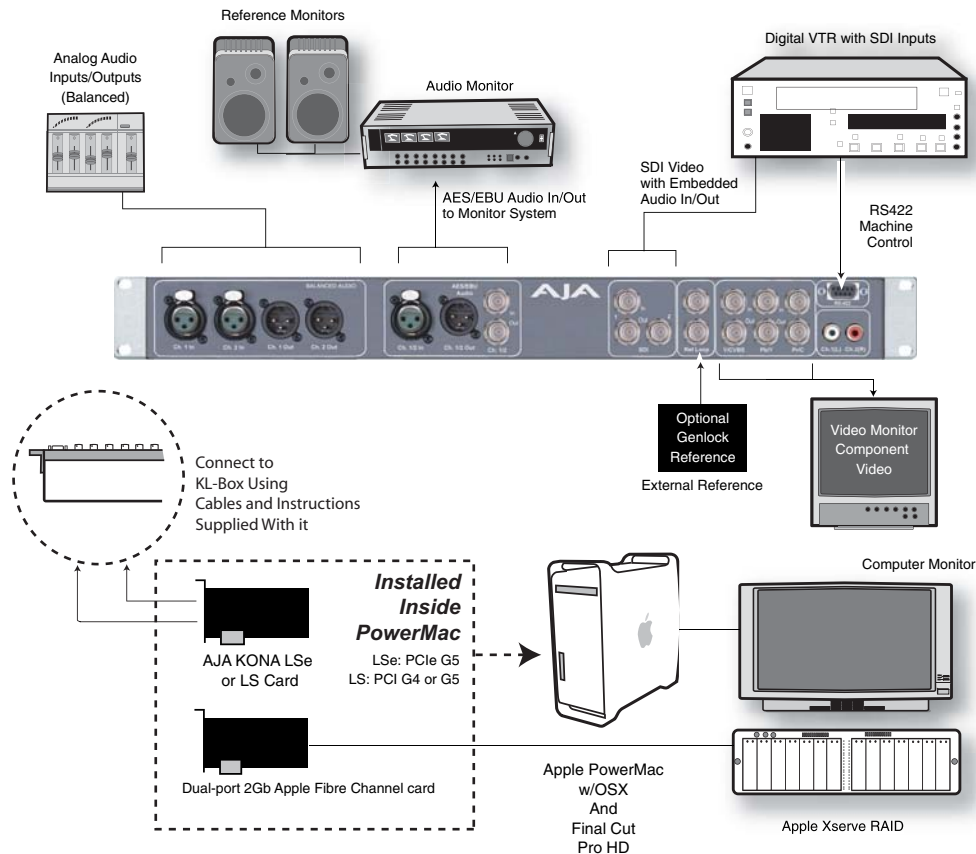

Typical System Connections—Shown with Optional KL-Box

Installing KONA LS Software

First ensure that Final Cut Pro is installed as detailed in its user documentation. Final Cut Pro *must be installed and have been run at least once prior to installing AJA KONA LS software*. Next, use the CD-ROM supplied with the KONA LS system to install necessary software drivers and KONA LS control panel. You cannot use KONA LS with Final Cut Pro until the AJA KONA LS software has been installed on the host Power Mac.

System software updates may occasionally become available to AJA KONA LS owners on our website (www.aja.com). We recommend checking occasionally for both software updates and additional product information.

Note: If your PowerMac has previously had another video capture or multimedia card installed, ensure you remove the card and uninstall any related software before installing KONA LS. This will prevent any hardware or software conflicts. KONA LS will operate properly on a PowerMac that also has an AJA Io installed.

Software Installation Procedure

Locate the AJA KONA LS Software CD packaged with your system. Then follow the procedure below to put the required software on a host system to be used with KONA LS. The PowerMac system must meet the minimums described in *Chapter 1: System Requirements*.

Note: Before installing KONA LS software, turn off any virus protection and security software that you may have installed on your computer.

1. Insert the KONA LS CD in the Power Mac
2. Locate the KONA LS CD icon on the OS X desktop.
3. Move the mouse cursor to the icon and double click to see the CD contents, which will appear in its own window.
4. In the window, locate the package file; it has an icon that looks like a box and has a “.pkg” suffix.

Note: Files ending in the “.mpkg” suffix are OS X installer files. These launch the OS X installer and tell it where and what to install on your system.

5. Double-click the package to log on and begin software installation.
6. The system will respond by asking you to authenticate who you are as currently defined on your OS X user profile. Enter the proper name and password at the Authenticate prompt; if you have multiple users defined, ensure that you log on as a user with administrator-level authority.



Log On Authenticate Prompt

7. Click on the *OK* button after entering a valid user and password.
8. The installer will launch and you'll see a series of installer screens.

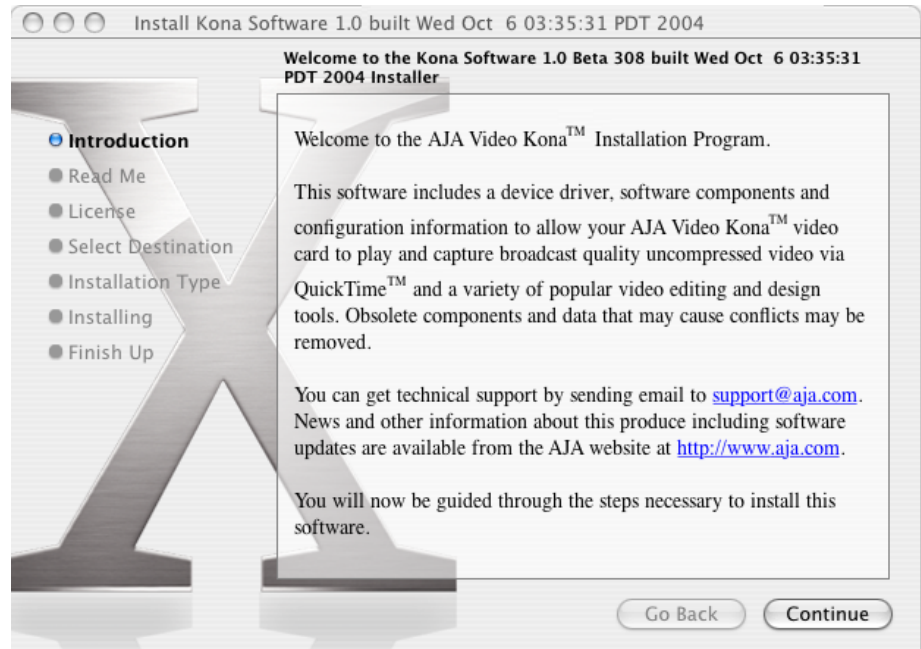

Initial Installer Screen

9. Click *Continue* to begin installation.
10. The next screen lets you know that the installer will check your PowerMac to ensure it has the hardware and software resources required (see Minimum Requirements in Chapter 1).

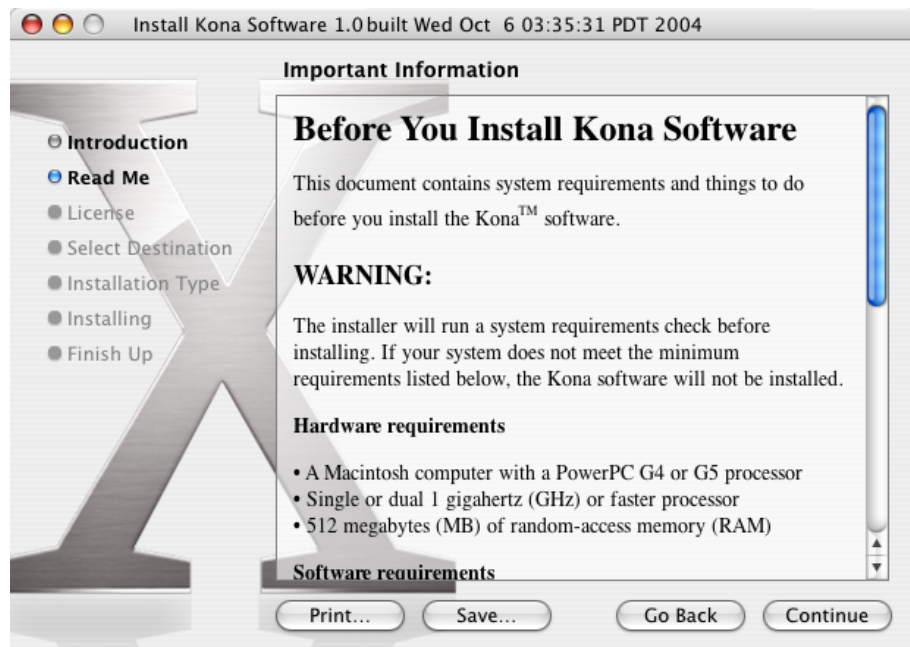

System Check Installer Screen

11. Read and agree to the Software License Agreement.

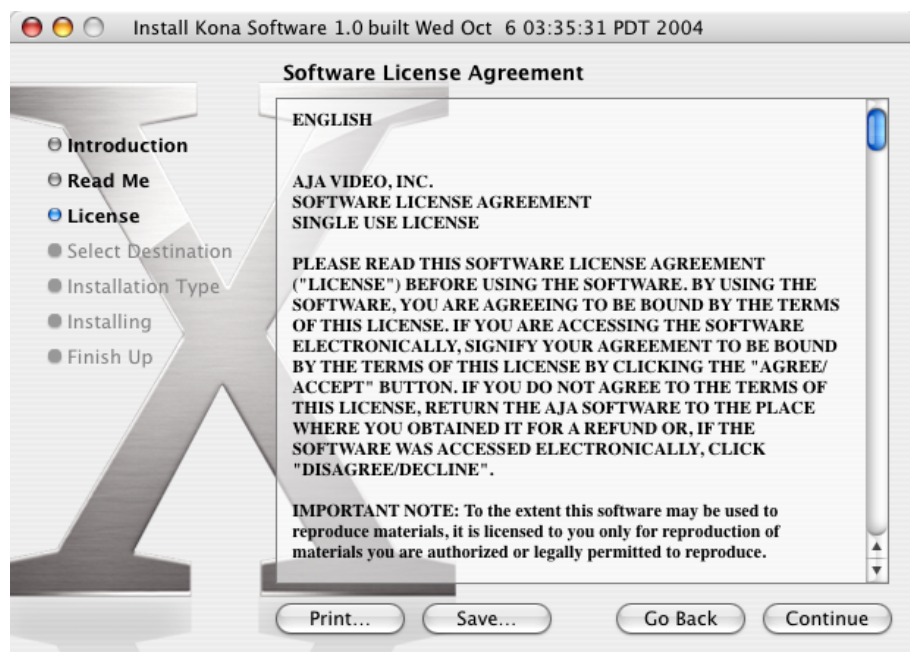

KONA LS Software License Agreement Screen

12. The next screen shows all the available drives on the Power Mac. Click on the boot drive that contains your system files (Apple default is “Macintosh HD”). A green arrow will point to the drive you’ve selected. Click the *Continue* button to proceed with installation.

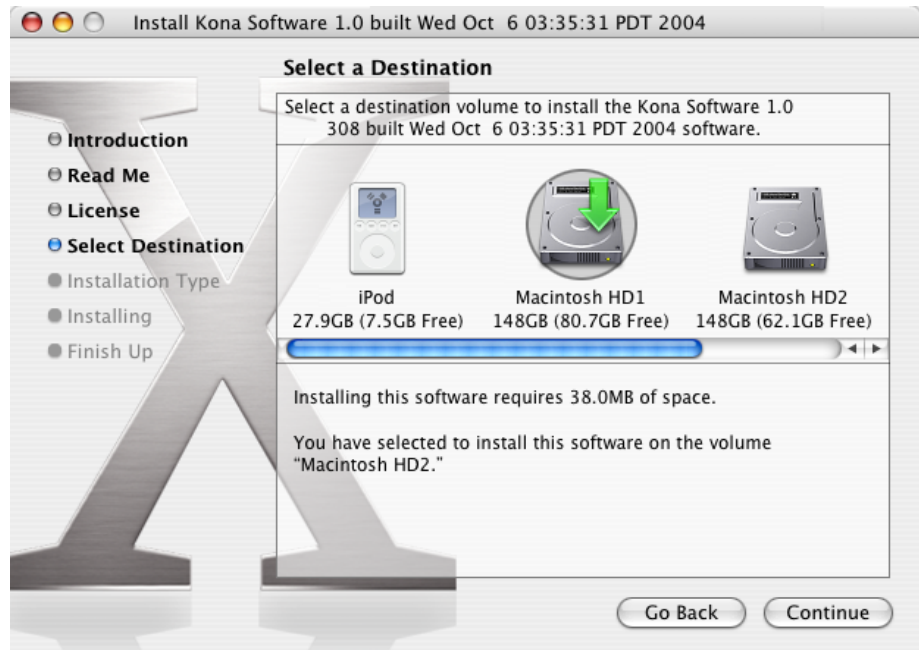

Select a Destination Drive For the KONA LS Software

13. At the next screen, click the *Install* button to place the software on the drive you previously selected.

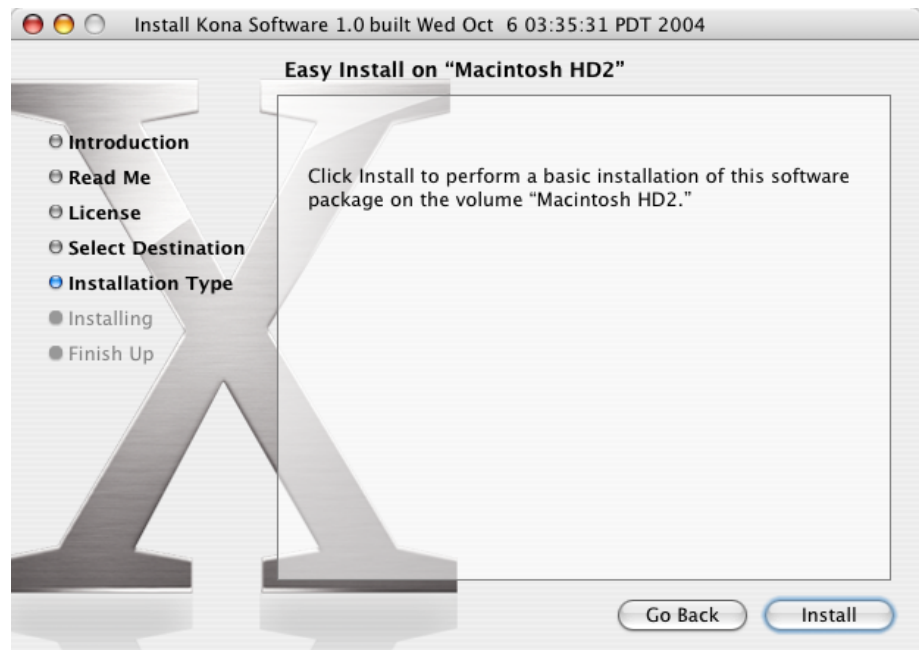

Easy Install, Installer Screen

14. A system prompt will pop up with a reminder that OS X must be restarted after installation. Click the *Continue Installation* button to proceed.

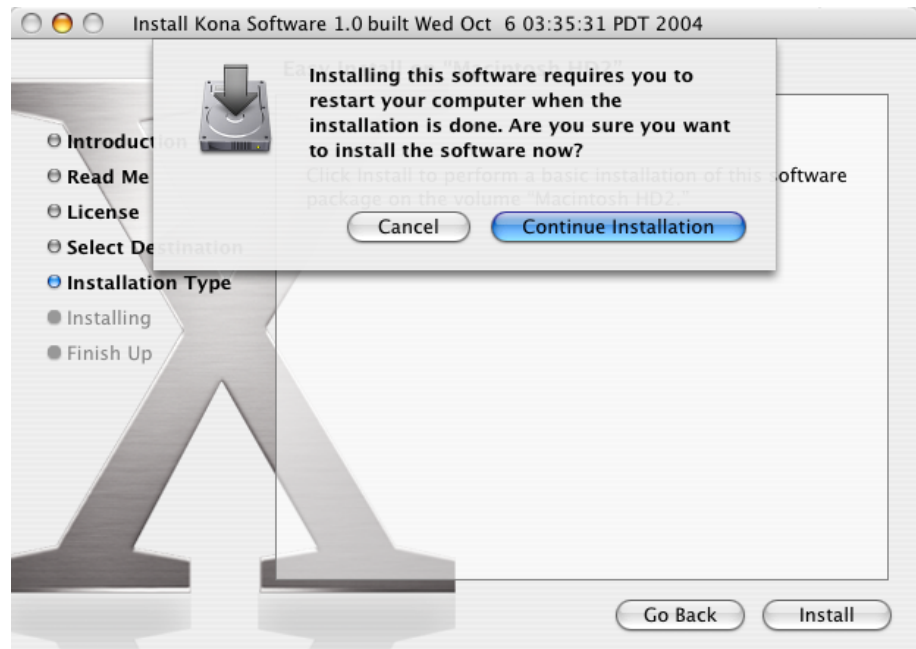

Restart OS X Reminder Prompt

15. The installer will run and put all the necessary KONA LS drivers, KONA LS Control Panel, presets and software on the desired hard drive. When it has completed installation, a final screen will be displayed announcing that “software was successfully installed.”
16. Click the Restart button to complete the installation procedure. The system will perform a software restart and be ready for use.

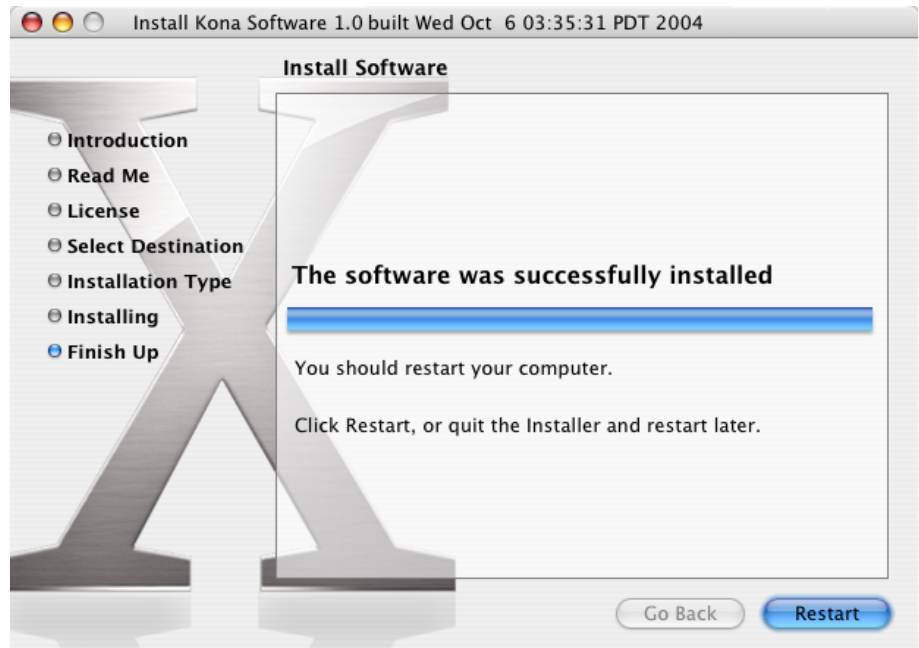

Final Installation Screen

Genlock and Your System

For video stability and proper system operation, it's always best to genlock all equipment to house sync. Although genlock is not absolutely required for KONA LS or your system, better quality and repeatable operation will be experienced by doing so. Usually, this means using a black burst generator output supplied to the system. On the KONA LS cable house sync is connected to "Reference In"; on the optional KL-box breakout box, house sync is connected to "Ref Loop".

Chapter 4:

Final Cut Pro and Other Software



Final Cut Pro

Final Cut Pro

Final Cut Pro (not included with KONA LS) ships with information already configured for most common system configurations. After you install the KONA LS software on your Power Mac, all you need to do to begin using it is to become familiar with the KONA LS Control Panel and how Final Cut Pro works with KONA LS.

With Final Cut Pro you'll choose the proper setups from the canned ones provided by AJA. These canned setups are called "Easy Setups" in Final Cut Pro and are available to use and edit under Audio/Video Settings in the "Final Cut Pro" menu (next to the apple menu).

You'll also need to get familiar with the KONA LS Control Panel, which will be used for source selection, configuring many KONA LS features, and for creating your own preset configurations for different applications.

The manual you are reading does not provide operational information about Final Cut Pro. Please read the user documentation provided with Final Cut Pro for information on configuration and operation. The chapter you are reading addresses configuration and setup unique to use of KONA LS with Final Cut Pro and other applications.

Using The KONA LS Control Panel

The KONA LS control panel is a software application that provides a simple visual way to see how the KONA LS card is currently configured and then make changes as desired. Settings—both what you changed and didn't—can be saved as a snapshot for recall at anytime. This lets you save settings associated with all your frequent tasks; then as you switch tasks you don't have to spend extra time constantly resetting card configurations—just load the previously saved settings for each task.

One thing you'll notice instantly about the control panel is that it represents a visual block diagram of how the card is set. The current status, input and output settings, and many other details can be viewed as a color-coded block diagram in the control panel.

Control Panel Basics

Although the KONA LS card auto-configures depending on the inputs present, and the Control Panel intuitively shows at a glance much about what the card is doing, there is even more information presented that may not be obvious. To ensure you make the most of the software, run the KONA LS application and look at its display. Then refer to the “Basics” described here to fully understand what you’re seeing and learn how to view and change the KONA LS system configuration.

Note: The KONA Control Panel also works with KONA LH, KONA 3 and KONA 2. However, the actual features and screens displayed differ slightly since the board feature sets differ. Only one KONA card can be installed in a Mac at one time.

Before we go into too much detail, here are some basic definitions you should know (please refer to the figure that follows for reference):

Block Diagram Screen—The top area of the KONA LS Control Panel shows a visual picture representing the processing (if any) that’s currently occurring, including inputs/outputs, reference source, and system status. Lines between inputs, the framebuffer, and outputs, show a video path. Where there are no lines, it shows there is no connection; this can be either because an input or output isn’t selected or because no video is present at the selected input. Icon objects on the block diagram screen (input/output icons, frame buffer, etc.—also called “widgets”—indicate their status by color (explained later) and can be clicked for context-sensitive information and choices. (These same choices can also be made from the tabbed Control panel screens.)

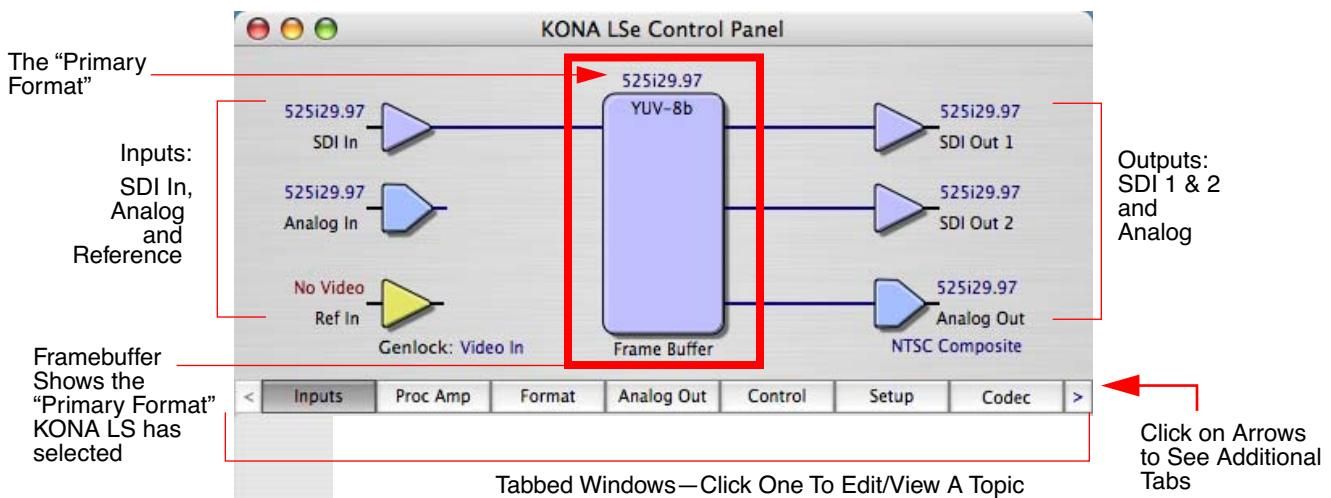

KONA LS Control Panel, Block Diagram

Framebuffer—The framebuffer is the “engine” in the KONA LS card where active video operations take place using Final Cut Pro, other 3rd-party applications, or even KONA LS itself. The framebuffer has a format (called the “Primary Format” and color space that it follows, as defined in the Tabbed Windows or via external application software (such as the “Easy Setups” in Final Cut). It is important to realize that inside the Macintosh many applications can use the KONA LS card (as you switch from window to window) and it may not always be obvious which currently controls it.

The KONA LS Control Panel displays the name of the application controlling the card. In some cases, applications may not always properly “let go” of the card as another takes over—you’ll be able to tell by looking at the Control Panel.

Primary Format—The video format currently assigned to KONA LS. This is the format that the framebuffer will use and is shown in the Control Panel using the color blue. All icons in blue are the same as the Primary Format used by the framebuffer. Also any text descriptions in the block diagram that appear in blue also indicate that something is in the primary format. So, for example, if you see that the input and output icons are blue, then you know that the same format is used throughout the video path and that no format conversion is being performed. If a different color is displayed on the input or output, say green for example, then you know that KONA LS is performing a format conversion in the video path.

Input/Output Icons—The input and output icons are triangles that together with their color show all the inputs and outputs and their status (selected, not selected, input present or not, format, etc.). A complete video path is shown when inputs and outputs are connected with lines going to/from the framebuffer.

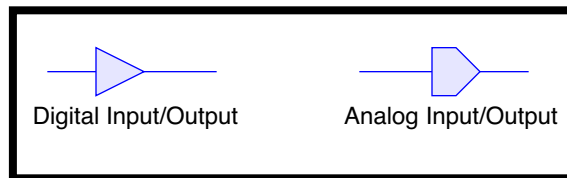

Input/Output Icons

Color Meanings—All items in the KONA LS Control Panel block diagram are color-coded to show what is happening in realtime. This applies to both icons and text. These colors have the following corresponding meanings:

Blue: video is same format as the Primary Format (framebuffer)

Red: the selected operation cannot be performed

Yellow: reference video (black burst or other reference source)

Tabbed Windows—The bottom area of the KONA LS Control Panel provides different information categorized by topic. Clicking on a “Tab”—or a block diagram element—will result in an information screen corresponding to a tabbed topic. The arrows at either side of the displayed tabs can be clicked to see any additional tabs not visible on the screen. If an arrow is “grayed out”, then it means there are no additional tabs in that direction. Each of these tabbed windows are described on the following pages. Tabs that can be selected are:

Inputs: view and edit input selections and how they are mapped

Proc Amp: view and edit the analog proc amplifier settings (brightness, contrast, hue, and saturation)

Formats: select the framebuffer primary video format for inputs/outputs

Analog Out: configure the component/composite analog output

Control: configures KONA LS operation (pass through, desktop, etc.) plus sets output timing.

Setup: configures Video and Audio options such as composite black level and analog audio monitor level.

Codec: used to select codec options such as whether a pause stops on a full frame or a single field (jitter shown or not) and 24 to 30 fps padding patterns.

Timecode: monitor and configure RP-188 (SDI embedded) timecode

Info: displays status information about the KONA LS card and how it is installed in the host Macintosh. This information is generally intended for troubleshooting/support.

Input Screen

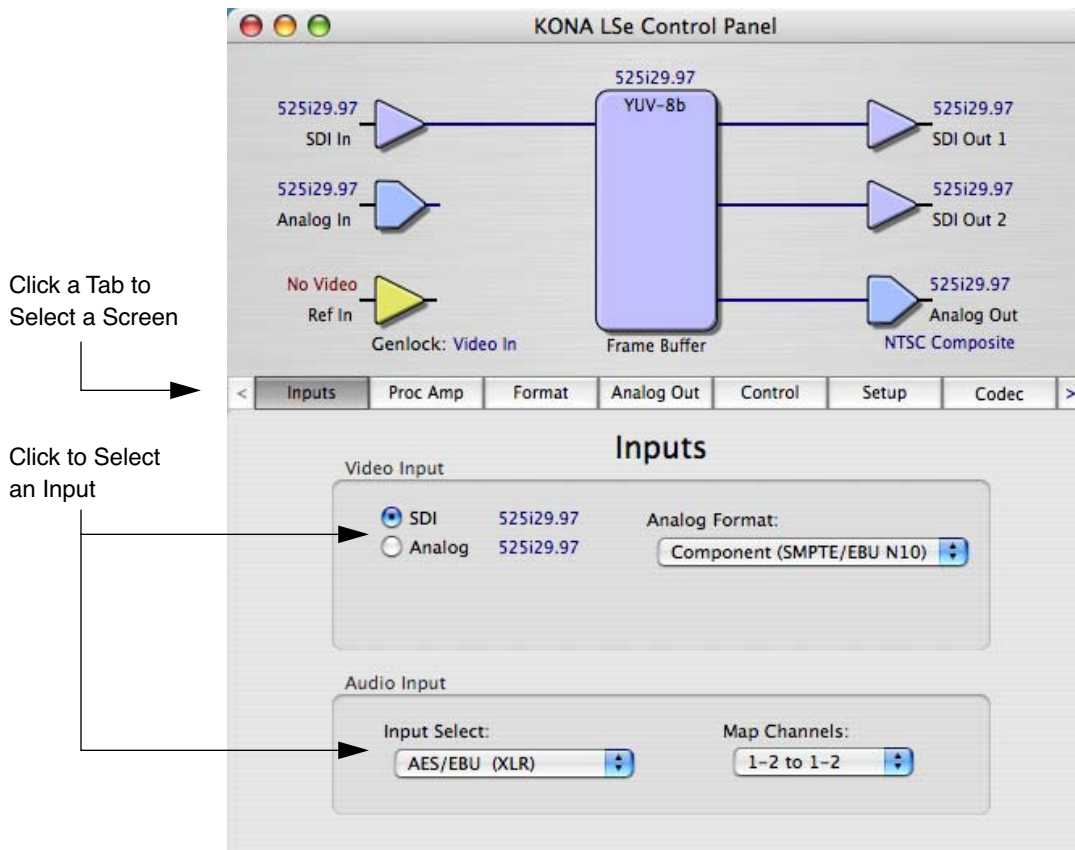

KONA LS Control Panel, Inputs Tab

On the Inputs screen you can view the currently selected video and audio input sources and map audio sources to the channels supported by Final Cut Pro (more on this later). Two information panes in the screen are provided: Video Input and Audio Input. (If an input/output has no video, it will be indicated on the block diagram as “No Video.”)

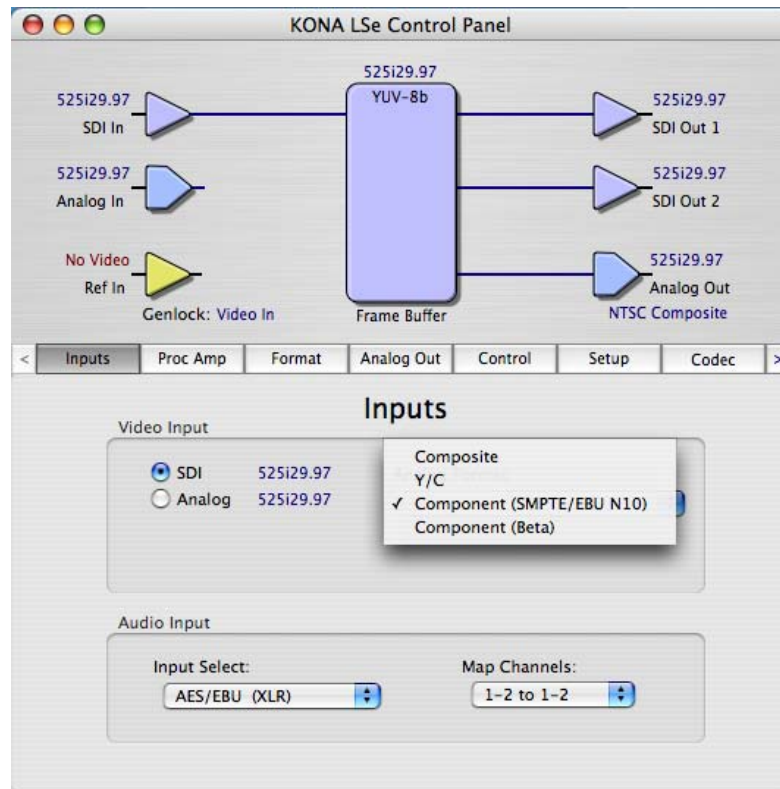

KONA LS Control Panel, Inputs Tab, Composite Analog Output Selected

Input Screen Settings

Video Input—These radio buttons allow you to see and change what’s currently selected and the video format that KONA LS has detected there (if any). In the example shown previously, it shows that video is selected at the SDI input and the format is 525 with a frame rate of 29.97. If Analog is selected, then you also need to select the Analog Format via a pulldown menu. Choices are:

- Composite
- Y/C
- Component (SMPTE/EBU N10)
- Component (Beta)

Audio Input—This pulldown menu allows you to pick where the audio comes from. KONA LS supports up to 6 channels of embedded digital audio, so you can choose out of the 16 channels that can be embedded in SDI, and pick which 6 to bring in (from the group 1-8 or 9-16). Since Final Cut Pro currently only supports two channels of audio, here you can also select which two channels from the 8 embedded will be mapped to Final Cut's two channels.

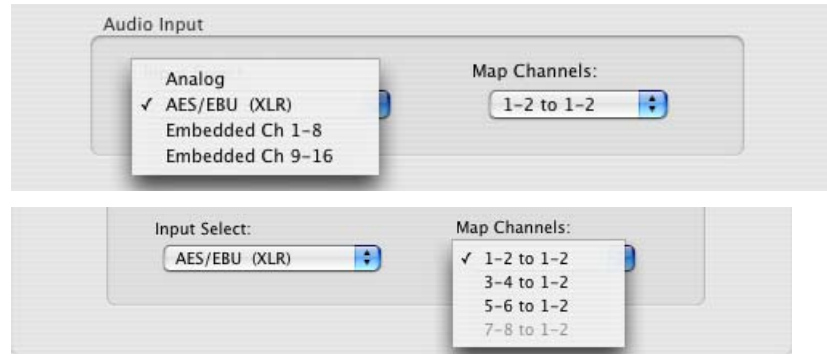

Proc Amp Screen

The Proc Amp screen settings affect the analog proc amplifier built into the KONA LS. Each of the four sliders controls a video parameter, with the middle being close to unity. If the value has been changed from the factory Unity setting, that value will be displayed in red at the right side of the slider. Clicking the Reset Unity button sets all four sliders back to unity.

Sliders:

- Brightness
- Contrast
- Hue
- Saturation

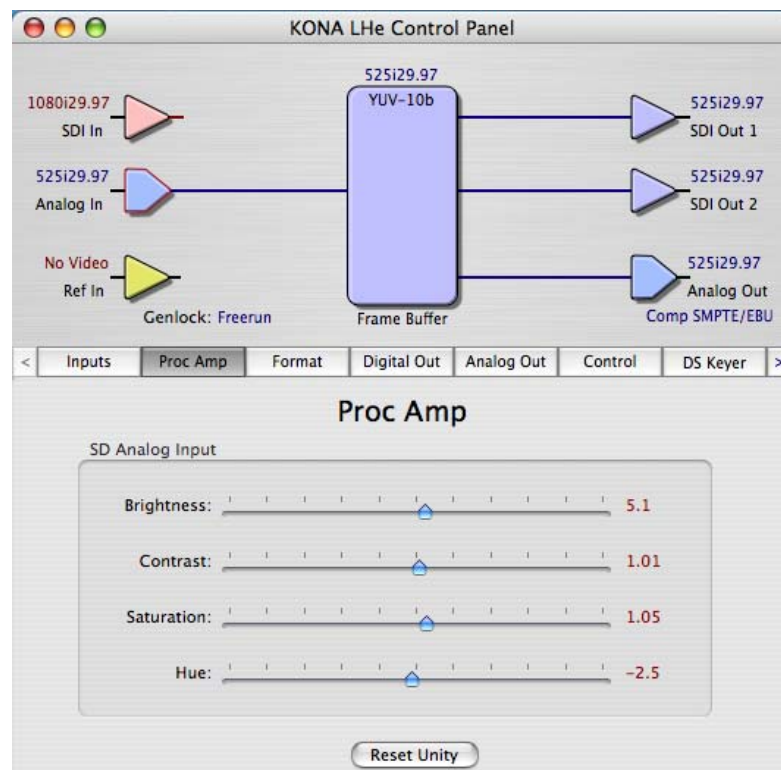

KONA LS Control Panel, Proc Amp Tab

Formats Screen

The Formats screen shows the video format currently in use by the KONA LS framebuffer (called the *Primary Format*) and allows you to change it. All throughout the Control Panel, choices are always presented based on what KONA LS can do with the signals available and the inputs/outputs selected.

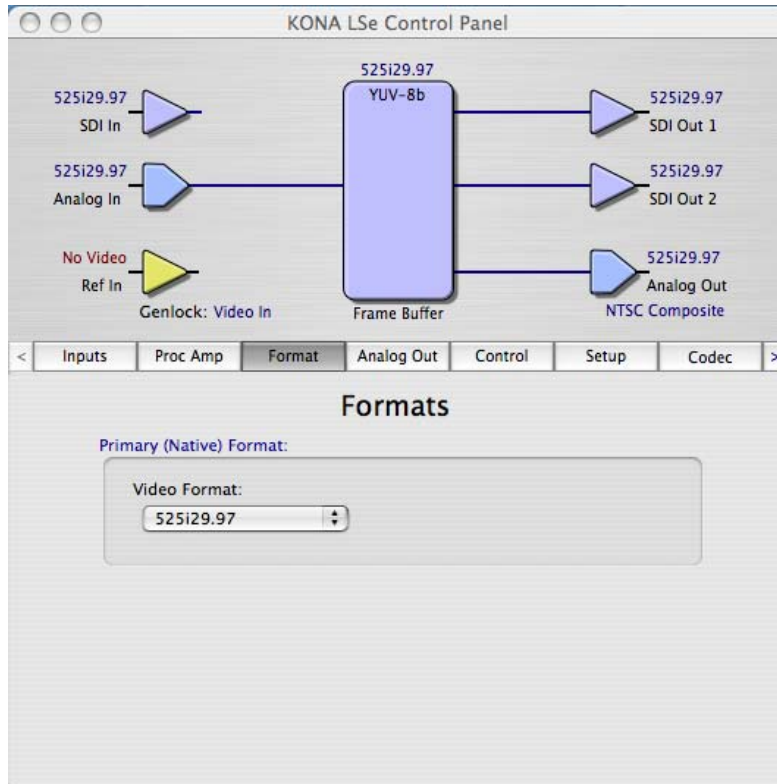

KONA LS Control Panel, Formats Tab, Showing Primary Formats Pulldown Menu

Format Screen Settings

Video Format—This pull-down menu shows the currently selected format. If you select an alternate value in the Primary Format using the pull-down, it will change the format used by KONA LS's framebuffer. When a change is made via the Video Format pull-down, the block diagram will change to reflect the new format. KONA LS Formats are: *525i 29.97* or *625i 25*

Analog Out Screen

KONA LS provides a high-quality analog component or composite output. This screen shows the current settings for that analog output, and allows you to re-configure it when desired (format and black-level).

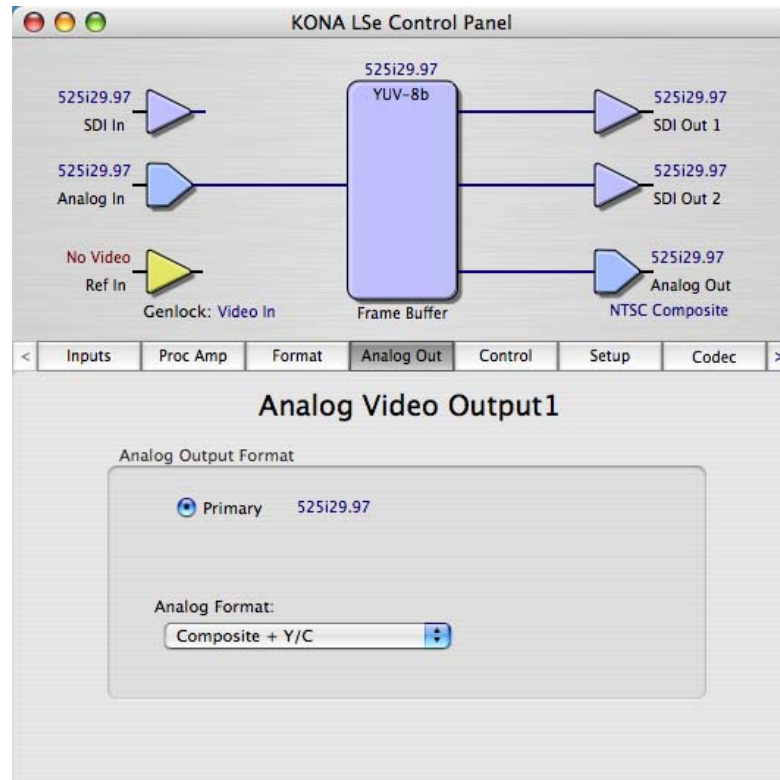

KONA LS Control Panel, Analog Out Tab

Analog Out Screen Settings

Analog Format—choices in the Analog Format pulldown menu vary depending upon the Analog Output video standard. Analog formats can include:

- Composite + Y/C
- Component (SMPTE/EBU N10)
- Component (Beta)
- Component (RGB)
- Component (RGB -HV)

Control Screen

The KONA LS can be controlled by various software applications running on a host PowerMac, and can also be used as a Macintosh Desktop extension. The Control Screen is where you select how the KONA LS will direct video and be used by application software. This screen also provides control for configuring output timing with regard to external reference video and horizontal/vertical delay.

At the top of the Control screen it will show the current Default KONA LS output and the application currently controlling the KONA LS card (if there is one). For example, in the screen shown here, the default output is the Macintosh Desktop and the only controlling application is the KONA LS Control Panel itself.

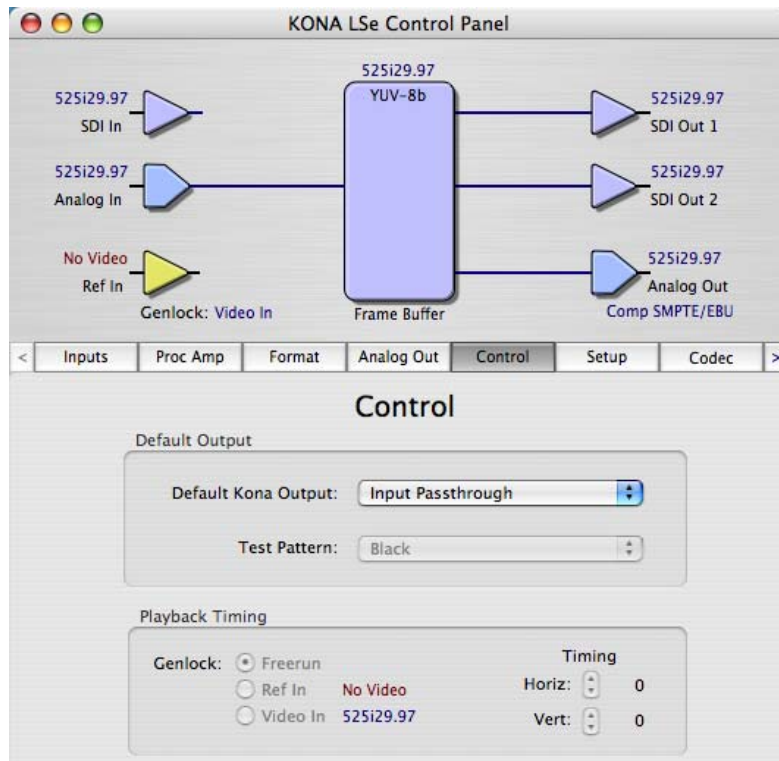

KONA LS Control Panel, Control Tab

Control Screen Settings

Default Kona Output—Here you select what video KONA LS will output as a default *when no application has control of the board*, such as when the Finder is active. Since KONA LS can be controlled by software applications as well as its own control panel, the output can change dynamically. When you select many video applications, they will grab control of the KONA LS card inputs/outputs. These settings determine what happens when an application that doesn't grab the KONA LS inputs/outputs is active. Choices available and their meaning are:

Macintosh Desktop: when selected, this selection causes the KONA LS program video output (digital and analog) to be an extension of the Macintosh desktop. MacOS windows and applications can appear (when applicable) on the KONA outputs.

Input Pass Through: this selection directs KONA LS to route video from its selected input through the card for processing and output. This is similar to using the KONA LS as a VTR in E/E mode (as far as video/audio pass through).

Note: Any application trying to play back audio outside of Final Cut will not work properly in *Input Pass Through*. This happens because while in Input Pass Through all audio is passed straight through the card, and any inserted audio is ignored.

Black: this selection directs KONA LS to output video black whenever an application isn't controlling the card.

Test Pattern: this selection directs KONA LS to output a choice of preset patterns—when no other QuickTime application is using the KONA board. In addition to the preset test pattern choices, a “Load File...” selection at the bottom of the menu allows you to load any standard Mac RGB graphics file (.tif, .psd, etc.) into the frame buffer for display.

Note: the graphic file will not be scaled to fit. If it's smaller than the current frame buffer format, KONA LS will center it in the frame. If it's larger than the current frame buffer format, it will be cropped on the right and bottom.

Once a graphic file is loaded into the frame buffer it will be retained until it is overwritten by another graphic or test pattern, or when power is turned off. Graphic file names are only “remembered” in the menu as long as the Kona Control Panel application is running.

Hold Last Application: this selection directs KONA LS to hold and output the last frame of video from the last application to control KONA LS. This can be helpful when operating in an environment where you're switching back and forth between multiple application windows.

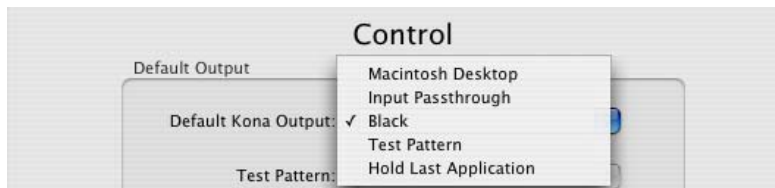

KONA LS Control Panel, Control Tab, Default Kona Output Pull-down Menu

Genlock (*Freerun, Ref In, Video In*)—Selects how KONA LS will synchronize program video:

Freerun: in this mode, KONA LS generates sync without an external reference source

Ref In: directs KONA LS to use the Ref Video source for sync (usually an analog black burst video signal)

Video In: directs KONA LS to use whichever video input source has been selected in the *Inputs* tab window for sync

Timing (*Horiz and Vert*)—these two pull-downs allow output timing adjustment with reference to the Ref Video source selected. The Horizontal reference can be adjusted by selecting a number of pixels (clocks) to offset. Vertical can be adjusted by specifying a number of lines to offset.

Setup Screen

KONA LS provides a high-quality analog component or composite output, generally used for monitoring. This screen shows the current settings for that analog output, and allows you to re-configure it when desired.

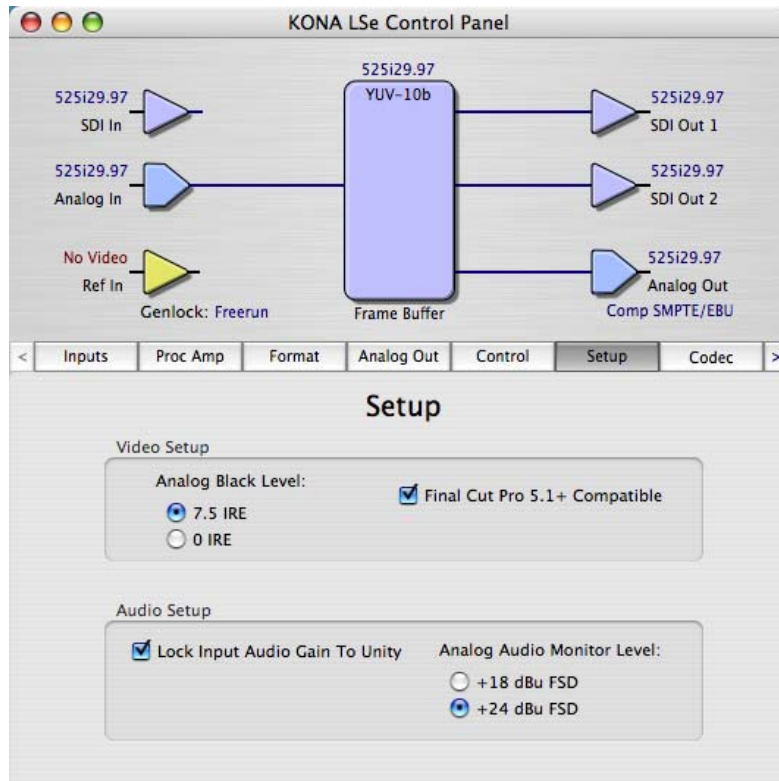

KONA LS Control Panel, Setup Tab

Setup Screen Settings

Analog Black Level—choices in the black Level pulldown menu are only available for the two Composite analog formats. Choices presented are for US or Japan settings:

7.5 IRE (NTSC US)

0 IRE (NTSC Japan)

Final Cut Pro 5.1+ Compatible—set this checkbox if you are running Final Cut Pro 5.1 or newer software. Not checking the box when running 5.1 (or newer) results in reduced capture accuracy.

Analog Audio Monitor Level Audio—when a KL-Box is connected to KONA LS, the button selected determines the audio level that will appear at the Analog Audio Output RCA connector pair (“FSD” is *full-scale-deflection* reading as measured on a VU meter). Select +18 for Europe or +24 for USA.

Lock Input Audio Gain To Unity—When set, the KONA card will ignore the Final Cut Pro gain setting and set the audio gain at unity. When not set, this checkbox tells the KONA card to get the audio gain setting from Final Cut Pro.

Codec Screen

This screen offers a variety of controls that determine how the card behaves under Final Cut Pro.

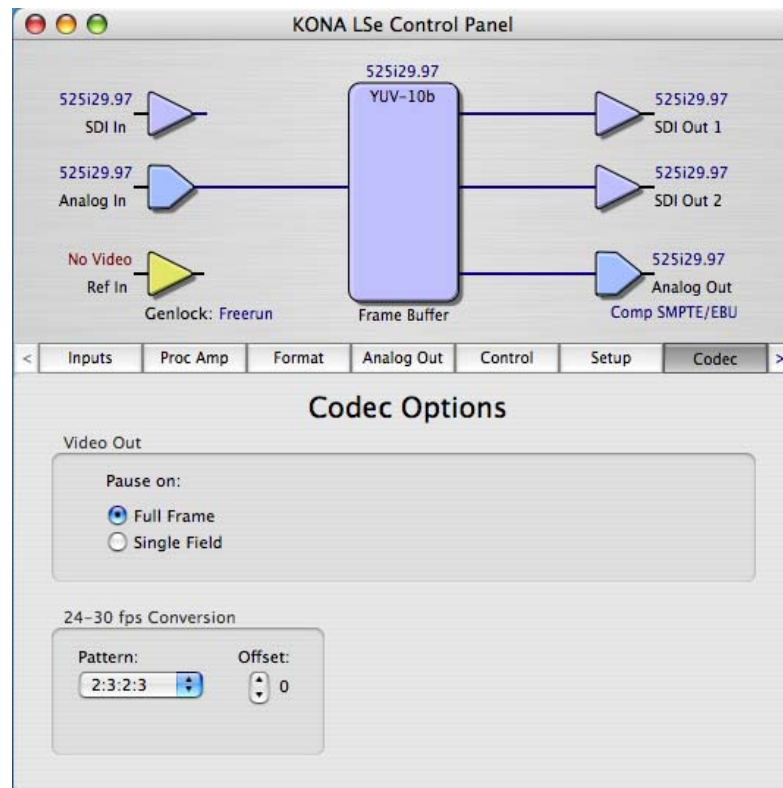

KONA LS Control Panel, Codec Tab

Codec Screen Settings

Pause On—these two choices determine what happens when Final Cut Pro is paused in stop mode:

Full Frame: both fields are displayed resulting in some jitter while paused.

Single Field: a single field is displayed, showing no flicker (useful when color correcting or whenever the flickering would be a distraction).

24-30 FPS Conversion—the value selected in this pulldown is used whenever, due to format selection, you've chosen to do 24 frames-per-second to 30 conversion where extra fields will be added to pad the existing ones. Depending on video content, selection of different field patterns may be useful in reducing jitter due to the content of adjacent fields. The numbers in the pattern choices specify the frequency with which inserted fields will be repeated. For example, "2:3:2:3" means duplicate a field twice, then the next field three times, then the next twice, and then back to three times.

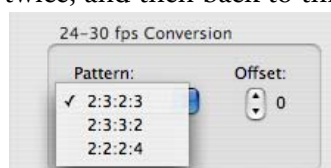

KONA LS Control Panel, Codec Tab, Frame-padding Pattern Choices

Timecode Screen

The timecode is used for both monitoring the RP-188 timecode embedded in the digital data stream and for selecting a timecode offset (if required) for the attached VTR (connected to KONA LS's RS-422 port)—and sent during assemble-edit mode.

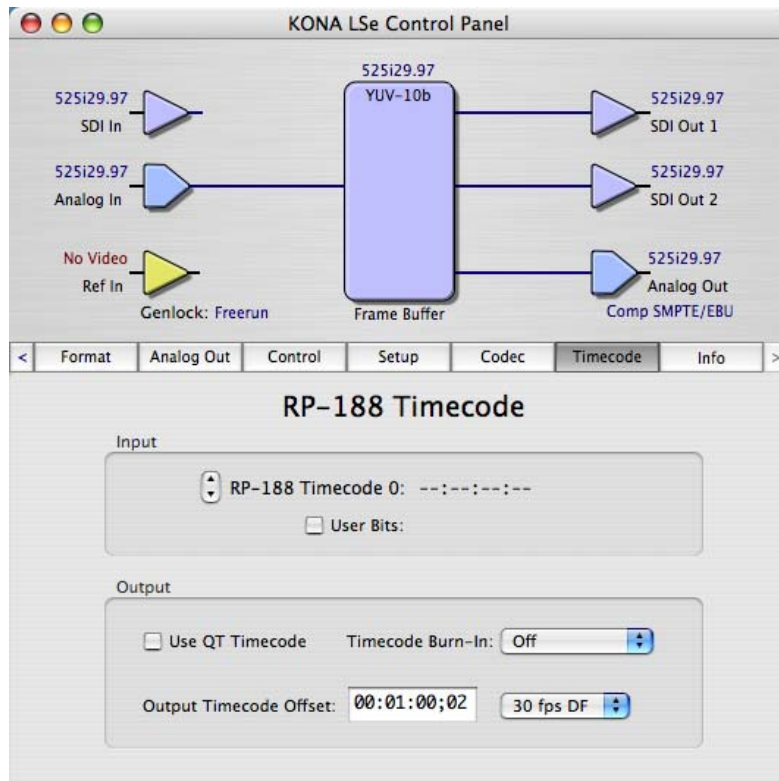

KONA LS Control Panel, Timecode Tab

Timecode Screen Settings

RP-188 Timecode <n>—in RP-188 timecode there can be multiple timecode values in the data stream. Use this pull-down to select the one you wish to monitor. The selection will be displayed in the timecode value displayed to the right of the pull-down.

User Bits—For monitoring Varicam timecode, you may wish to monitor the user bits embedded in the timecode. If you set this checkbox, KONA LS will detect and interpret the Varicam user bits and display them next to the checkbox.

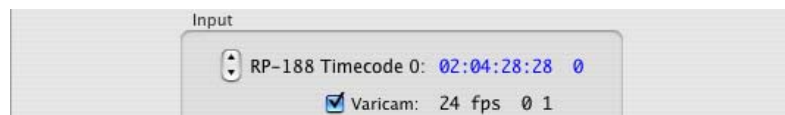

KONA LS Control Panel, Timecode Tab, User Bits Checked

Use QuickTime Timecode—when checked, this directs KONA to output timecode from the QuickTime timecode track. When not checked, KONA uses the *Output Timecode Offset* value plus the number of frames into the movie. Note: not all QuickTime applications use or support timecode tracks—so sometimes the QuickTime timecode is missing or not meaningful.

Output Timecode Offset (entry field and FPS pull-down)—this text entry field allows you to specify a timecode offset for use with Final Cut Pro (or any other application that has timecode offsets that are user-controlled). In FCP, go to “Timeline Options” and locate the “Starting Timecode” value. Use that same value here as the “Output Timecode Offset” to ensure the timecode is synchronized.

Timecode Burn-in—this pulldown selects whether the timecode value is “burned-in” on video output from KONA LH. If set to “OFF”, timecode will not be keyed over the video. If set to “timecode”, then the timecode value will be keyed over the output video. This can be useful for synchronizing, choosing edit points, dailies, and many other purposes.



Note: SMPTE RP 188 defines a standard for the transmission of time code and control code in the ancillary data space of an SDI video signal. Time code information is transmitted in the ancillary data space as defined in ANSI/SMPTE 291M. Multiple codes can be transmitted within a single digital video data stream. Other time information, such as real time clock, DTTR tape timer information, and other user-defined information, may also be carried in the ancillary time code packet instead of time code. The actual information transmitted through the interface is identified by the coding of a distributed binary bit. Equipment manufacturers can use the meta data for different purposes.

Info Screen

This Tabbed screen shows the KONA LS software files that have been installed on your system. This information may be needed if you talk to an AJA Customer Service representative to determine if files are missing or need updating.

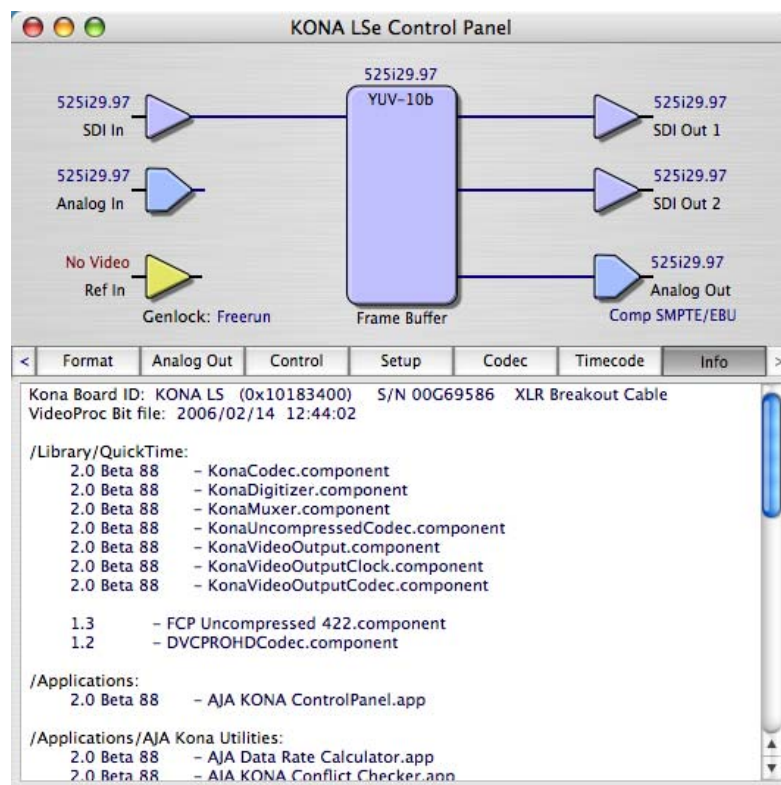

KONA LS Control Panel, Info Tab

Saving Your Control Panel Presets

After configuring the KONA LS Control Panel via the Tabbed screens, you can then save all your settings as a snapshot for later recall—called a preset. In this way, you can organize the presets for all your typical tasks, saving time by not having to manually reconfigure each time. To save a preset, simply go to “File -> Save Preset...”. Be sure to give the preset a meaningful name. Thereafter the preset will be available under the Control Panel “Presets” menu.

Easy Setups for Typical Uses

Final Cut and KONA LS together make working with multiple formats an easy proposition. Inside of Final Cut, equipment and setting presets are available in groups called Easy Setups, from which you can choose typical system configurations. A large set of Easy Setups are supplied with KONA LS and installed along with the KONA LS software. These canned choices can be used directly or as the basis for making your own customized Easy Setups unique to your system. By duplicating an Easy Setup and then making changes to it, you simplify the process of configuring and re-configuring when working with new formats.

Although this manual assumes you’re familiar with Final Cut Pro and have read its documentation, let’s review Easy Setups and how to use them effectively with KONA LS.

At the simplest level, Final Cut lets you choose and edit presets for capturing media, device control, and for project sequences. These presets are defined in the *Audio/Video Settings* menu. Just like Easy Setups, here also there are factory defined choices, plus you can create and make your own. When you have a set of presets you want to use again, you can store them as an “Easy Setup.”

On the following pages we’ll further review the *Easy Setups* menu and *Audio/Video Settings* Menu.

Easy Setups Menu

Both the Easy Setups menu item and the Audio/Video Settings menu item are located under the main *Final Cut Pro* menu.

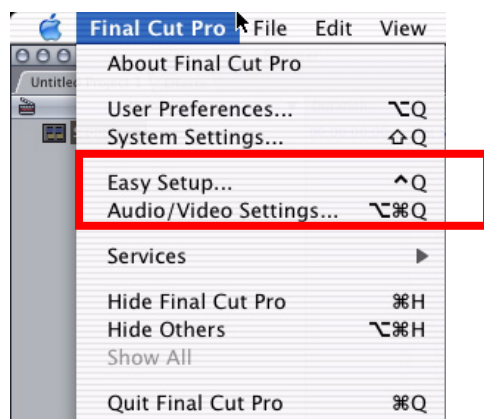

Easy Setup and Audio/Video Menu Items

Click on the Easy Setups menu item and Final Cut Pro will present the Easy Setup dialog window:

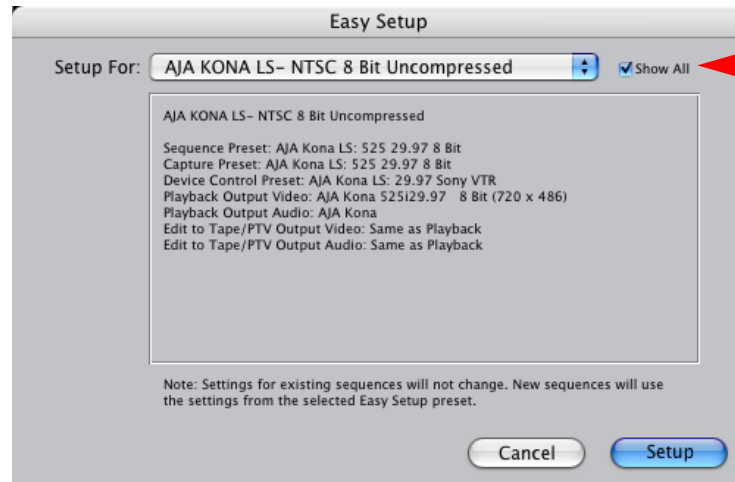

Ensure "Show All" is checked so you can see the AJA Easy Setups

Easy Setup Dialog

At the top of the Easy Setup dialog is the currently selected Easy Setup. It can be changed by clicking on the pulldown arrow at the right. Doing so results in a list of the Apple-supplied Easy Setups stored on the system. If you wish to see all of the Easy Setups, factory, AJA, and user-defined, then ensure the "Show All" checkbox is marked at the right side of the dialog.

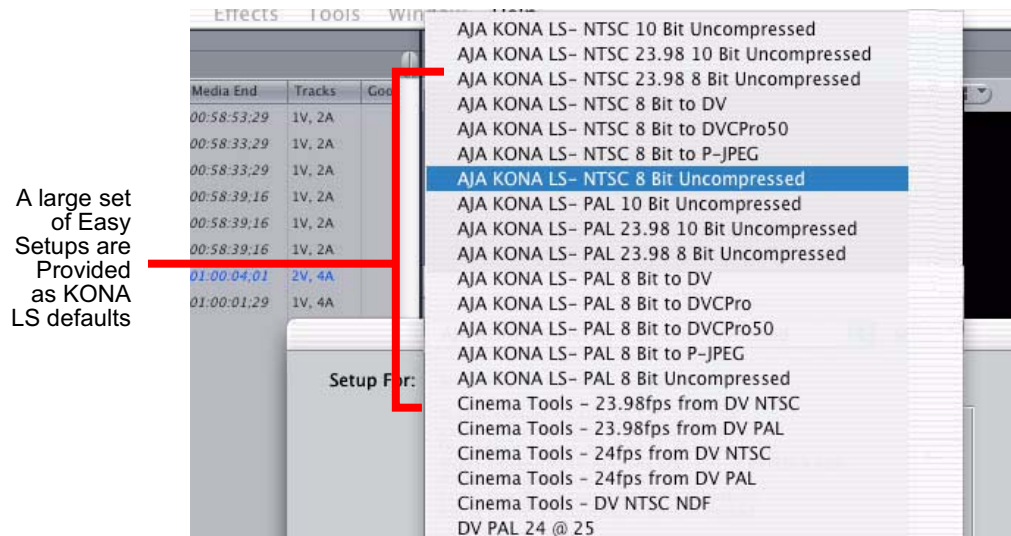

Factory Easy Setups

To choose a new Easy Setup from the list, click on the pulldown menu and select a desired choice. The choice won't take effect until you click the *Setup* button, but you will be able to see the description for the choice just by selecting it (without clicking the *Setup* button). Descriptions provide a paragraph summarizing what the Easy Setup is intended for and then each of the presets are explained (Sequence, Capture, Device, Playback Output, and Edit to Tape Video/Audio Outputs).

Note: Easy Setups and Final Cut Pro presets can be tricky to configure for optimal performance. We highly recommend choosing an AJA KONA preset close to your desired configuration and then editing a copy of this preset instead of trying to set one up from scratch.

Easy Setups For Use With KONA LS

The factory default Easy Setups currently shipped with KONA LS are shown below. Your list may differ as AJA is continually improving and adding functionality.

Easy Setup (as listed in FCP Pulldown)	Description/Usage
AJA KONA LS- NTSC 8 bit uncompressed	Use this preset when working with 625 at a 29.97 framerate. Material will be processed as Uncompressed 8-bit.
AJA KONA LS- NTSC 10 bit uncompressed	Use this preset when working with 625 at a 29.97 framerate. Material will be processed as Uncompressed 10-bit.
AJA KONA LS- NTSC 8 bit to DV	Use this preset when working with 625. Material will be processed as DV.
AJA KONA LS- NTSC 8 bit to DVCPro50	Use this preset when working with 625. Material will be processed as DVCPro50.
AJA KONA LS- NTSC 23.98 8 bit uncompressed	Use this preset when working with 625 at a 23.98 framerate. Material will be processed as Uncompressed 8-bit.
AJA KONA LS- NTSC 23.98 10 bit uncompressed	Use this preset when working with 625 at a 23.98 framerate. Material will be processed as Uncompressed 10-bit.
AJA KONA LS- NTSC 8 Bit to P-JPEG	Use this preset when working with 625. Material will be processed as Photo JPEG.
AJA KONA LS- PAL 8 bit uncompressed	Use this preset when working with 525 at a 29.97 framerate. Material will be processed as Uncompressed 8-bit.
AJA KONA LS- PAL 10 bit uncompressed	Use this preset when working with 525 at a 29.97 framerate. Material will be processed as Uncompressed 10-bit.
AJA KONA LS- PAL 8 bit to DV	Use this preset when working with 625. Material will be processed as DV.
AJA KONA LS- PAL 8 bit to DVCPPro	Use this preset when working with 625. Material will be processed as DVCPPro.
AJA KONA LS- PAL 8 bit to DVCPPro50	Use this preset when working with 625. Material will be processed as DVCPPro50.
AJA KONA LS- PAL 23.98 8 bit uncompressed	Use this preset when working with 525 at a 23.98 framerate. Material will be processed as Uncompressed 8-bit.
AJA KONA LS- PAL 23.98 10 bit uncompressed	Use this preset when working with 525 at a 23.98 framerate. Material will be processed as Uncompressed 10-bit.
AJA KONA LS- PAL 8 Bit to P-JPEG	Use this preset when working with 525. Material will be processed as Photo JPEG.

Audio/Video Settings Menu

The Audio/Video Settings menu in Final Cut Pro contains a series of tabbed windows where you define the presets in specific categories such as A/V devices or in what format media is captured. When you open the Audio/Video Settings window, it shows a summary of the currently selected Easy Setup. Other tabbed windows are available with greater details about each category. On the initial summary window you can see the selected presets for the Easy Setup as well as change specific presets.

The presets you can change on the Summary window are:

Sequence Preset—select one of these as the editing timebase for new sequences. If you make a change to Sequence Presets, the change will only take effect on any new sequences you create—currently active sequences will not be changed.

Capture Preset—select one of these to set the incoming source format you'll be capturing. Ideally select the maximum quality format you'll be using for most of the material so there will be no need to re-render later as clips are added from the bin to the sequence.

Device Control Preset—select the AJA Video KONA LS device (NTSC or PAL as desired). This tells Final Cut to control the VTR attached to KONA LS or KL-Box.

A/V Devices (Audio and Video Playback)—select the KONA LS as video and audio playback devices for Final Cut and the format to be output.



Audio/Video Settings, Summary Window

To Create A New Easy Setup

If you have a group of presets that you'd like to use continually, then you can create a new Easy Setup by modifying the settings of the Easy Setup currently selected (pick one most like the one you want to create) and then saving it under a new name:

1. Change the currently selected Easy Setup by making changes at the Summary tabbed window via the pulldown menus.
2. When everything is set as desired, click on the *Create Easy Setup* button at the bottom of the Summary window.
3. A new dialog will pop up. Enter a descriptive name for the new Easy Setup (i.e., 10-bit SDI from Video Server) in the *Name* field.
4. Enter a sentence or two describing what is unique about the Easy Setup in the *Description* field.
5. Click the *Create* button to store the new Easy Setup.

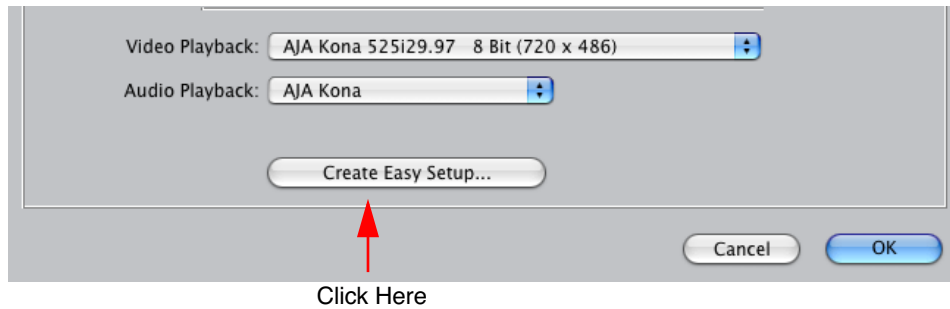

Audio/Video Settings, Creating a New Easy Setup

At any point in the above procedure you can go to the other tabbed windows and make additional changes. For example, in the Sequence Presets, Capture Presets, and Device Control Presets windows you can select a preset and click on an *Edit* button to change specific aspects of the preset. As an example, under *Device Control Preset* you might wish to change the Time Source on your VTR from LTC to VITC, or change the pre-roll and post-roll values. When you save a Setup, it defaults to saving in the Final Cut Pro *Custom Setups* folder.

Each of the tabbed preset screens are described on the following pages for your convenience. For more information, please read the Final Cut Pro user documentation.

The Sequence Presets Window

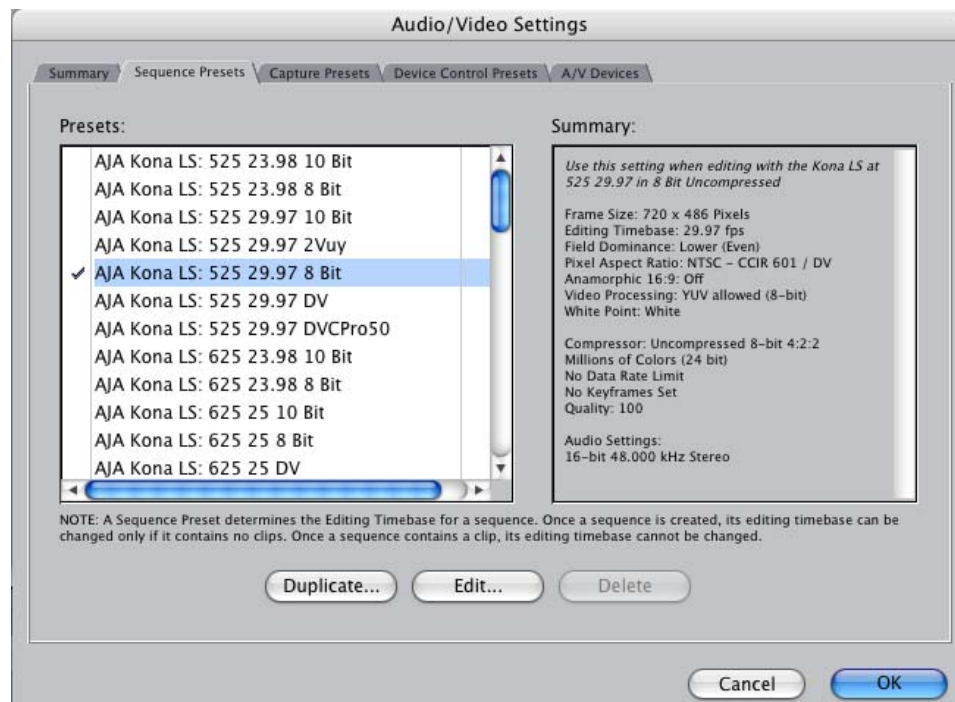

Audio/Video Settings, Sequence Presets Window

This window allows you to select an editing timebase for the current sequence.

Once you add a clip to the sequence this cannot be changed. For example, once you've selected uncompressed 10-bit NTSC 48 kHz, you then have to stay in that timebase and can't switch to another. By clicking in the leftmost column (see the checkmark in the sample screen above), you select a new Sequence Preset for use. The checkmark tells which Preset is in use—highlighting a choice alone does not select it.

If you select an editing timebase you can then edit it (click the Edit button) or copy and rename it as another (click Duplicate). When editing a timebase you can change the following:

- Select video processing properties (how to render)
- Frame size and aspect ratio
- Pixel aspect ratio
- Field dominance (none, upper, or lower)
- Editing timebase
- Set QuickTime video codec settings (quality and type)
- Select audio sample rate

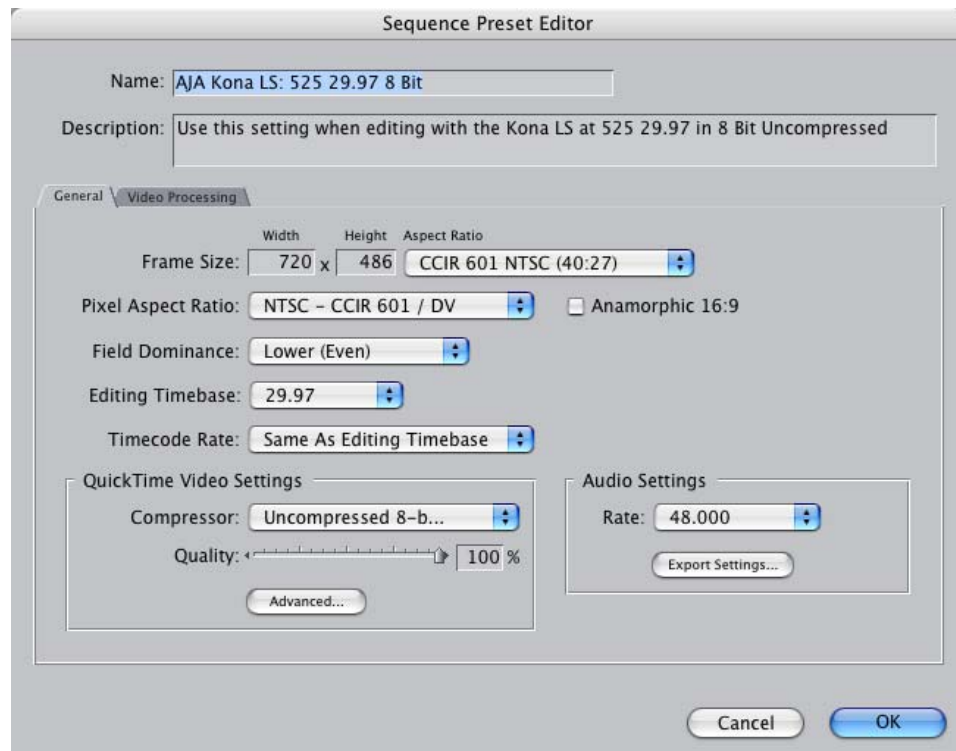

Audio/Video Settings, Sequence Presets Editor Window

The Capture Presets Window

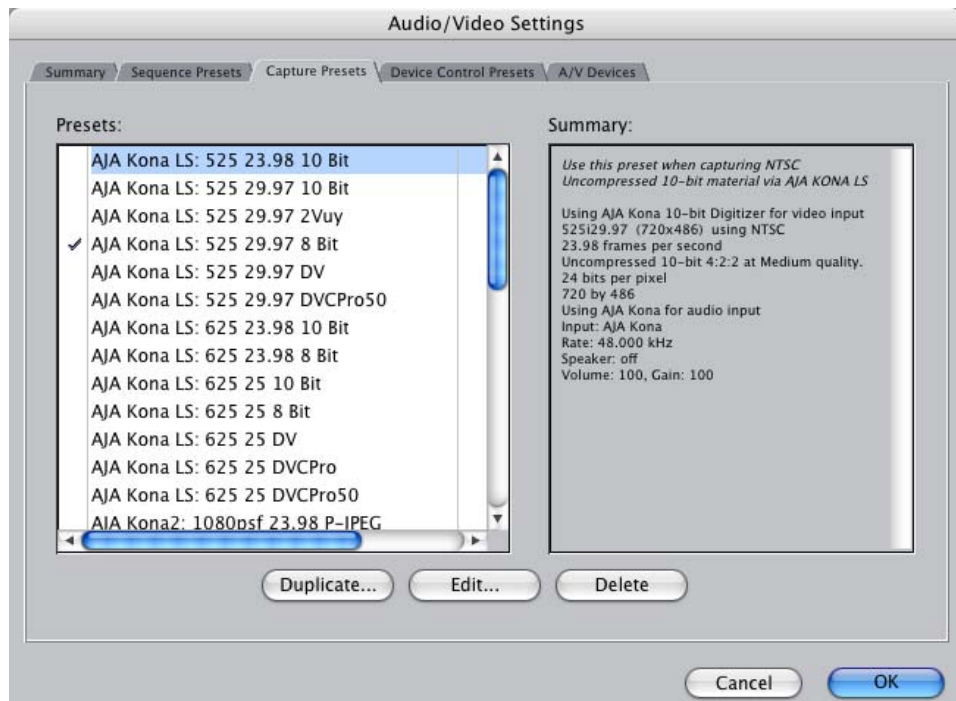

Audio/Video Settings, Capture Presets Window

This window lets you choose a preset format for incoming source video and audio media you'll be capturing. Select the maximum quality format you'll be using for most of the material so there will be no need to re-render later. The information on the right window pane describes the preset and all its parameters. If you select a format by making a checkmark in the left column, you can edit it (click the Edit button) or copy and rename it as another (click Duplicate). The only exceptions to this are those presets marked with a lock icon; those can be duplicated, but when you try to edit one the system reports they're locked and can only be copied (it will create the copy for you when you try to edit).

Factory AJA presets are easily identified by "AJA" at the beginning of their name.

Since Capture Presets will be used frequently as you bring media into KONA LS, we'll discuss the edit screen next.

Capture Presets Editing

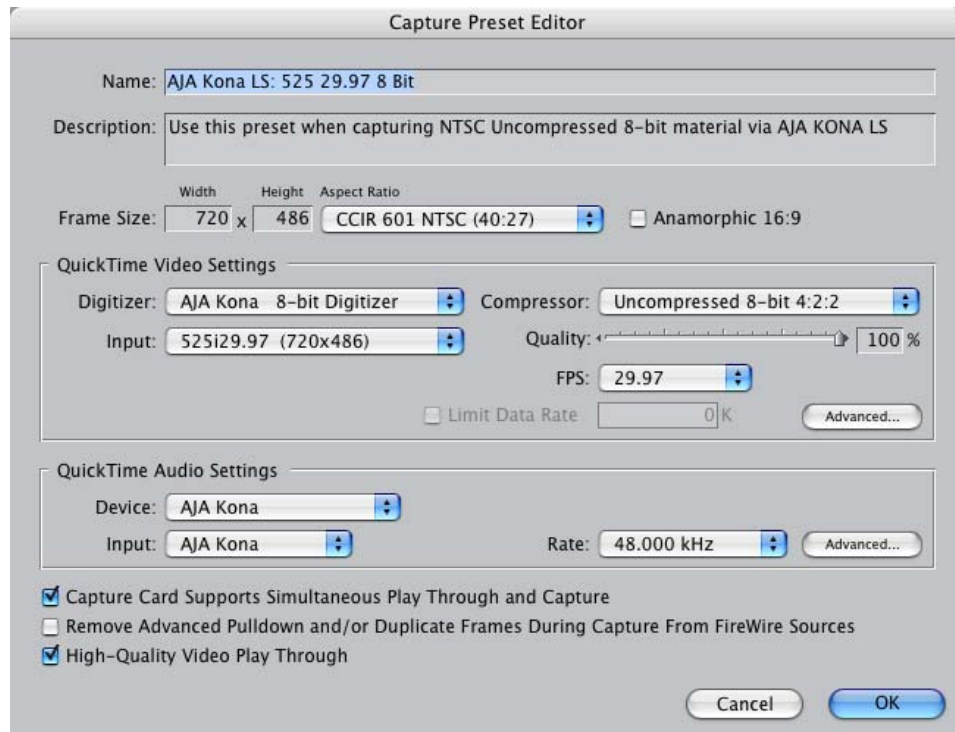

Audio/Video Settings, Capture Presets Editing Window

Note: Whenever a Preset is being copied as the basis of a new preset, always change the name and description to fit the new preset so users aren't confused between it and the original.

Frame Size—below the name and description are the frame size settings. These can be changed via the pulldown menu. Selecting a new *Aspect Ratio* value also changes the values in the width and height fields.

QuickTime Video Settings—these settings select a video input source and affect how it's processed by Final Cut Pro. The *Digitizer* pull-down menu selects whether you want the selected input source to be digitized as 8-bit or 10-bit uncompressed video as it comes into KONA LS. The *Input* pull-down selects the primary format KONA LS will use to capture input video. The *Compressor* pull-down selects a codec that tells Final Cut how to process the video; the codec selected should be chosen for compatibility with the Digitizer setting selected. For example, if your Digitizer setting is 10-bit Uncompressed, then the Compressor setting should be one of the 10-bit choices available. The *Quality* slider should be set to 100 percent when capturing uncompressed; for other formats use an appropriate quality level. Set the *FPS* (Frames Per Second) setting to the correct frame rate. The *Advanced* settings button opens a new screen providing choices of codec-specific options. For uncompressed codecs these probably are not unneeded; for other codecs choose the options desired.

QuickTime Audio Settings—these settings select an audio input source and affect how it's processed by Final Cut Pro. The *Device* pull-down should be set to AJA Kona. The *Input* pull-down selects that KONA LS (AJA Kona) will be used for capturing audio—it does not select the specific inputs. For specific audio input selection use the KONA LS Control Panel. The *Rate* pull-down selects a sample rate; it should always be set to 48 kHz for KONA LS. By clicking on the *Advanced* button, a new screen will be displayed where you can select between 8- and 16-bit sampling—AJA recommends 16-bit for optimum sound quality. (This has nothing to do with input format, as KONA LS supports 20-bit SD embedded audio, and 24-bit AES audio.)

The Device Control Presets Window

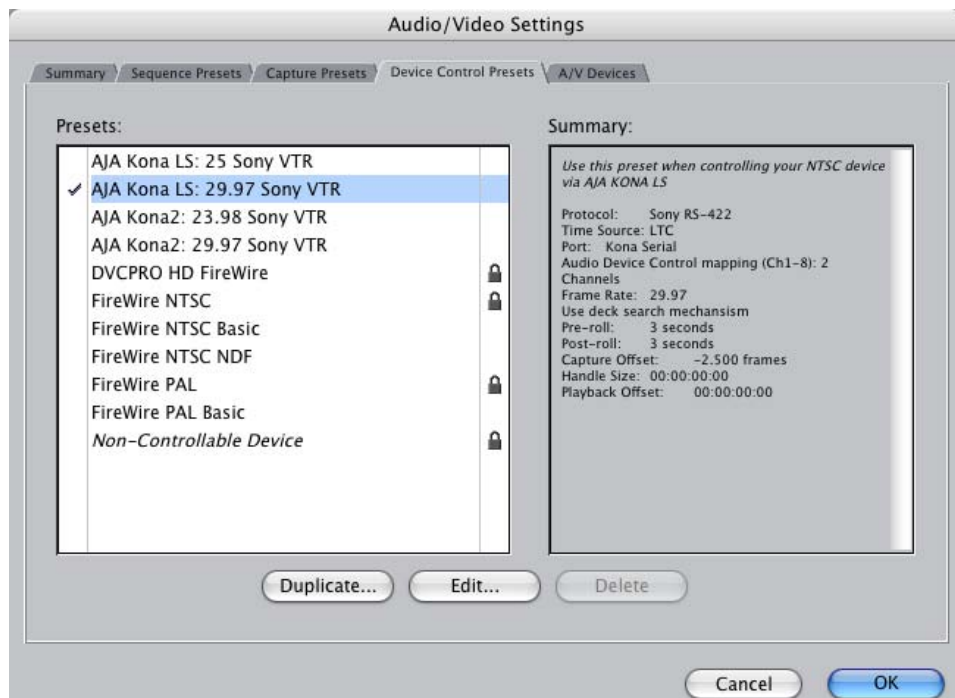

Audio/Video Settings, Device Control Presets Window

This window selects machine control parameters for an attached VTR. Your choice here tells Final Cut to use the VTR attached to KONA LS. Alternatively, you could also select a different device for input/output instead of KONA LS; for example, if you have a IEEE 1394 camcorder attached to the Power Mac's FireWire port you might choose "FireWire NTSC." The information on the right window pane describes the current machine control settings and parameters for the VTR attached. For KONA LS presets this means the VTR attached at the RS422 port on KONA LS. For non-KONA LS presets, this means camcorder/VTRs attached directly at the FireWire port or via some other interface.

If you select a preset you can edit it (click the Edit button) or copy and rename it as another (click Duplicate). The only exceptions to this are those presets marked with a lock icon; those can be duplicated, but when you try to edit one the system reports they're locked and can only be copied (it will create the copy for you when you try to edit).

When editing a Device Control preset you can change the following:

- Name and description of Device Control preset
- Protocol for capture/playback VTR (for KONA LS this will be RS422)
- Audio Mapping
- Time Source (LTC/VITC/both/etc.)
- Port
- Frame Rate
- Default Timecode (Drop Frame etc.)
- Capture/Playback Offsets (to correct for VTR versus Final Cut timing issues)
- Handles/Pre-roll/Post-roll
- Auto Record and PTV

KONA LS ships with VTR Device Control Presets for Sony and Panasonic VTRs. Select a Device Control Preset for the desired frame rate. Presets for both Sony and Panasonic VTRs are provided with these frame rates: 23.98, 24, 25, 29.97, and 59.94.



Device Control Preset Editor

Name:

Description:

Protocol:

Audio Mapping:

Time Source:

Port:

Frame Rate:

Default Timecode:

Use Deck Search Mechanism

Capture Offset: Pre-roll: seconds

Handle Size: Post-roll: seconds

Playback Offset: Auto Record and PTV after: seconds

Audio/Video Settings, Device Control Presets Editor Window

The A/V Devices Window



Audio/Video Settings, A/V Devices Window

The A/V Devices window selects the current hardware playback device for both audio and video. Typically, you'll select KONA LS for both playback devices. The format chosen determines the Primary format for the KONA LS board during playback. The *Video Options* button is greyed out for KONA LS (use the KONA LS Control Panel for video configuration; the *Audio Options* button opens a second dialog where Final Cut gives options for changing bit depth, number of channels, and the sample rate. Since Final Cut currently only supports 2 channels of audio, AJA recommends you leave all of these settings as set in the factory defaults.

You may wish to use a different KONA LS output for final Print-to-tape from Final Cut. You can select that in this window by clicking the checkbox "Different Output for Edit to Tape/Print to Video." This allows you to select via a pull-down menu any KONA LS video output and audio output.

The window also allows you to turn on and off device and audio output warnings.

Checking the System with a Simple Test Project of Bars and Tone

To test that you've installed the KONA LS drivers and have audio and video monitoring correctly configured, try creating a simple Final Cut Pro project with bars and tone.

1. Select an Easy Setup as previously discussed (go to the Final Cut Pro menu and select *Easy Setup*; then select a desired preset).
2. Select *New Project* from the File menu.

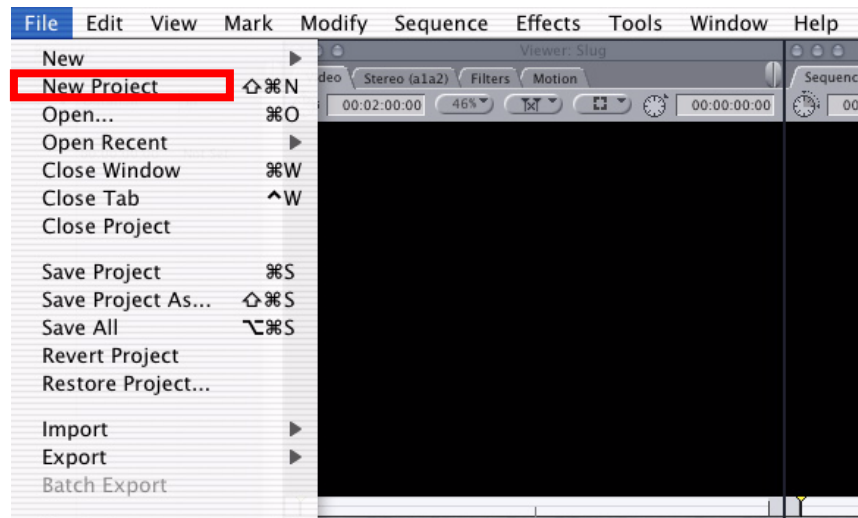

Create a New Project

3. The Sequence window timeline will be at the bottom of the screen and a Browser window will be at the top left. Look at the Browser window and locate the “Effects” tab at the top right. Click on it.
4. Locate the Viewer window in Final Cut and click on the Filmstrip pulldown menu button (it’s a “filmstrip” icon with an “A” on it). Select “Bars and Tone NTSC” or “Bars and Tone PAL”. The viewer window will display bars after you do this.
5. Click the mouse cursor on the Bars and Tone in the Viewer window and drag it to the beginning of the sequence window. You’ll see the bars and tone show up on the sequence where it can them be played.
6. Go to the beginning of the sequence by clicking on the left-most icon and then click the “Play” icon. You should see and hear the bars and tone on your video monitor and audio monitoring system.

If you don't see bars on the external video monitor and hear tone, check your connections and ensure KONA LS is selected in the Easy Setups and Audio/Video Settings as necessary.



Click Filmstrip Button in Viewer Window

...Then select "Bars and Tone"

Finally, click in the viewer window and drag the "bars" to the Sequence window.

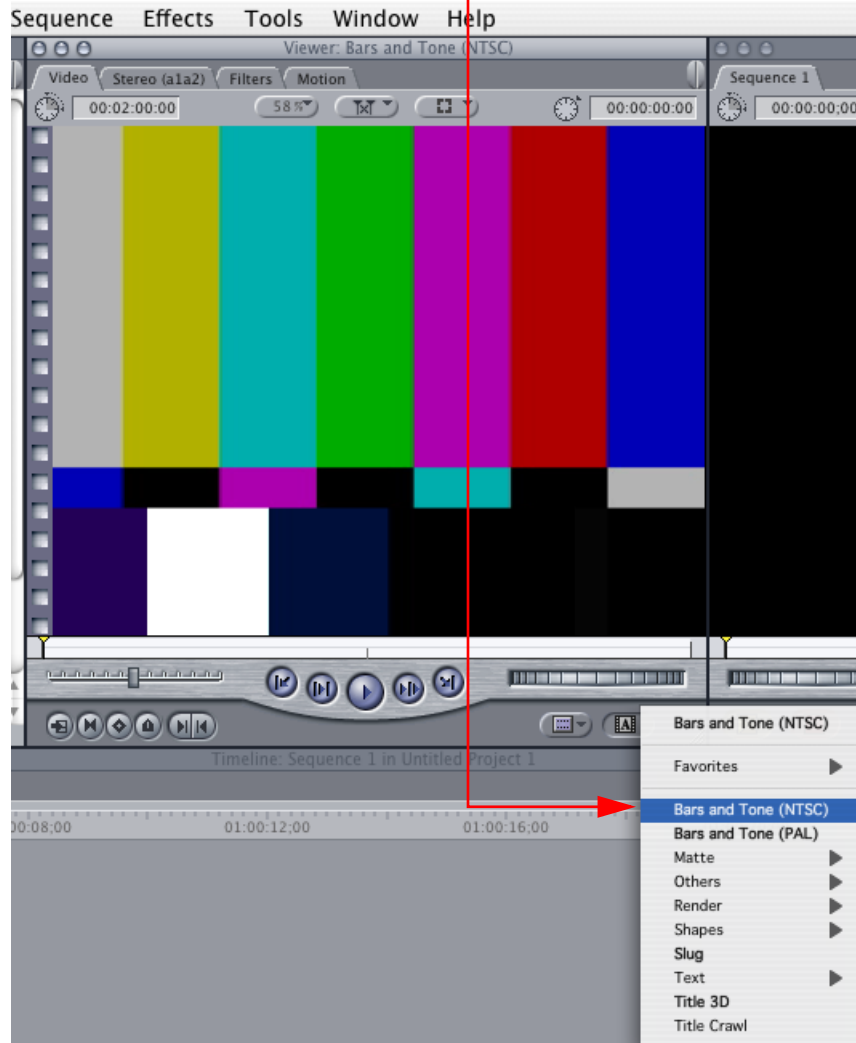

Click and Drag Bars and Tone From Viewer Window to Sequence



Bars and Tone
In Sequence
Window

Click "Play" to
Test the
System

Sequence Window Showing Bars and Tone Clip Dragged from Viewer

If everything works properly, go ahead and try capturing audio and video media from your VTR.

Using 8-bit Versus 10-bit Video

While both 8- and 10-bit uncompressed video are capable of providing excellent quality broadcast video, 10-bit represents a significantly higher quality and is preferable in many situations.

Because 10-bit video has four times the numerical precision when compared to 8-bit, it has a signal-to-noise ratio 12 db higher than 8-bit video.

Visually, in 8-bit video compared to 10-bit video, you will notice a substantial difference. In 8-bit video there will be “contour lines” or “striations” visible, particularly noticeable in scenes having soft gradients like a ramp or sunset. For example, if a sky region is mostly the same color but varies by only a few digital numbers from one side of the picture to another, you may see contour lines where the signal passes from one digital value to the next higher value.

Since each numerical value in a 10-bit system is only one fourth as large as an 8-bit system's, these contours become invisible and the sky varies smoothly.

10-bit video is often used when the source and output video (or “master”) is also 10-bit. Even if the input and/or output video is 8-bit, a 10-bit “project” will still maintain a higher quality when there is a significant amount of effects rendering involved.

Industry standard professional mastering formats—Sony Digital Betacam for Standard Definition and Panasonic D5 for High Definition—are both true 10-bit formats.



Chapter 5: Troubleshooting

If You Run Into Problems

One useful way to find the source of problems is to isolate your system to the smallest size where the problem still occurs and then note all the symptoms. This serves to eliminate areas not involved in the problem and make finding the problem easier.

Once you've noted problem symptoms, look through the following table and see if any of the symptoms are listed. If so, check the items listed. If you later need to call for customer service, let them know all of the things you've tried and when and how the symptoms appeared.

Table 5-1. Problem Solving by Matching Symptoms to Remedies

Symptom	Check
Disk RAID cannot keep up (dropped frames etc.).	Ensure the disk system is providing at least 50 MB/second sustained transfer rate
Dropped frames during playback.	<ol style="list-style-type: none">1. Canvas/Viewer zoom setting exceeds the fit-to-window setting. Change to "Fit-to-Window."2. RAID cannot sustain the data rate of the clip/sequence.3. The sequence setting does not match the "playback output setting" found at FCP Audio/Video Settings -> AV Output.4. Virus checking software running in the background (disable it).5. Scratch drive not set to the RAID.
Dropped frames during record.	<ol style="list-style-type: none">1. RAID cannot sustain the data rate of the capture preset codec.2. Virus checking software running in the background (disable it).3. Scratch drive not set to the RAID.
Media is not being captured from desired external device.	Check the settings in the <i>Input</i> tab of the KONA LS Control Panel application. Also check equipment cables.

Table 5-1. Problem Solving by Matching Symptoms to Remedies

Symptom	Check
Dropped frames during playback	Look for scroll bars in the viewer or canvas as a warning sign that the zoom setting exceeds the fit-to-window.
Changes made to Final Cut's configuration aren't remembered or you need to force a change to them.	<p>Under some circumstances, Final Cut Pro may need to be initialized back to the factory default state as it was when you installed it. The easiest way to do this is to locate Final Cut's preference file and discard it.</p> <p>To do so, follow this procedure:</p> <ol style="list-style-type: none"> 1. Locate the file named "Final Cut Pro 4.0 Preferences". <p><i>Note: path to file is "Macintosh HD/users/username/library/preferences/final cut user data."</i></p> <ol style="list-style-type: none"> 3. Click and drag that file to the Trash Can icon and drop it there. <p>When you next start up Final Cut Pro, it will present the "Choose Setup" prompt (as in initial installation) where you can again choose a desired KONA LS input format in the "Setup For" pulldown and re-enter a desired system scratch disk (your RAID).</p>
Video in the canvas stays frozen during playback.	<ol style="list-style-type: none"> 1. The sequence setting does not match the "playback output setting" found at FCP Audio Video Settings -> AV Output. 2. Canvas/Viewer zoom setting exceeds the fit-to-window setting. Change to "Fit-to-Window."
Video output is black.	<ol style="list-style-type: none"> 1. External video is set to "No Frames" (View -> External Video). 2. The "Playback output setting" found at FCP Audio Video Settings -> AV Output is set to "none" or to a non-KONA LS device.
Video stutter during playback.	RAID cannot sustain data rate.
Red render bar occurs when placing a clip on a sequence.	The sequence setting does not match the clip setting.

Updating Software

Check on the AJA Video website (www.aja.com/support_kona.html) for software updates. If any are available, download the file and read any associated instructions prior to installing the software.

Support

When calling for support, first check over your system configuration and ensure everything is connected properly and that current Final Cut presets and Easy Setups match what you are trying to do. Even if you cannot find the cause of the problem, having this information at hand will help when you call Apple or AJA Customer Support for help.

If the problem is unknown or you need general help, first contact the dealer where you purchased the product. AJA dealers offer product support for many service requirements.

If the problem is a Final Cut Pro operational issue, Power Mac system issue, or Xserve RAID issue, then call Apple Customer Support for help.

If the problem is an AJA Video KONA LS issue, then contact AJA Video Customer Support using one of the methods listed below:

Contacting by Mail Address:

443 Crown Point Circle, Grass Valley, CA. 95945 USA

Telephone: 1.800.251.4224 or 1.530.274.2048

Fax: 1.530.274.9442

Web: <http://www.aja.com>

Support Email: support@aja.com

Apple Resources

Apple provides a large amount of support information online at their support website. Information provided includes answers to top questions, discussions on specific topics, and software downloads for updates and utilities.

You may also enroll in AppleCare for extended support of hardware and software products. Information is provided on the Apple Support website on how to enroll in AppleCare.

General Apple Support Website for information on all products:
<http://www.info.apple.com/>

Power Mac Support Area: <http://www.apple.com/support/powermac/>

Xserve Support Area: <http://www.info.apple.com/usen/xserve/>

Xserve Discussion Area:

<http://discussions.info.apple.com/>

WebX?f50@176.UAD8aKWnمبر.0@.3bb84b79

Final Cut Pro Web Support: <http://www.info.apple.com/usen/finalcutpro/>

Final Cut Discussion Area:

<http://www.apple.com/support/finalcutpro/>



Appendix A: Specifications

Video Input

Digital:	8 or 10 bit SDI, SMPTE-259
Analog:	
Composite/S-Video (Y/C):	NTSC, NTSCJ, PAL 12 bit A/D, 2x oversampling 5 line adaptive comb filter decoding +/- .25 db to 5.0 MHz Y Frequency Response +/- .25 db to 1 MHz C Frequency Response .5% 2T pulse response < 1.5% Diff Phase < 1.5% Diff Gain
Component:	SMPTE/EBU N10, Betacam 525 line, Betacam 525J, 12 bit A/D, 2x oversampling +/- .25 db to 5.5 MHz Y Frequency Response +/- .25 db to 2.5 MHz C Frequency Response .5% 2T pulse response <2 ns Y/C delay inequity

Video Output

Digital:	8 or 10 bit SDI, SMPTE-259
Analog:	
Composite/S Video:	NTSC, NTSCJ, PAL 12 bit D/A, 8x oversampling +/- .2 db to 5 MHz Y Frequency Response +/- .2 db to 1 MHz C Frequency Response .5% 2T pulse response < 1% Diff Phase < 1% Diff Gain
Component:	SMPTE/EBU N10, Betacam 525 line, Betacam 525J, RGB 12 bit D/A, 8x oversampling +/- .2 db to 5.5 MHz Y Frequency Response +/- .2 db to 2.5 MHz C Frequency Response .5% 2T pulse response <1 ns Y/C delay inequity

Audio Input

Digital:	2-channel 24 bit AES/EBU, 48KHz sample rate Synchronous or Non-synchronous (Internal sample rate conversion)
	24 bit SMPTE-259 SDI embedded audio, 6 ch, 48kHz synchronous
Analog:	2-channel balanced input +24dbu Full Scale Digital 24 bit A/D, 48 KHz sample rate +/- 0.2db 20 to 20 KHz Frequency Response 108db dynamic range -94db THD



Audio Output

Digital: 24 bit AES/EBU, 48 KHz sample rate, 2-channel

24 bit SMPTE-259 SDI embedded audio, 6 ch, 48 KHz synchronous

Analog: 2-channel Balanced output (XLR)

+24dbu Full Scale Digital (0dbFS)

24 bit D/A, 48 KHz sample rate

+/- 0.2db 20 to 20 KHz Frequency Response

100db dynamic range

-88db THD

2-channel unbalanced output (RCA-jack): requires KL-Box option

Reference Input

Analog Color Black (1V) or Composite Sync (2 or 4V)

Non terminating, 75 ohm (1 BNC on standard breakout cable; with optional KL-Box, 2 BNCs, one of which is a loop-through)

Machine Control

RS-422, Sony 9-pin protocol Connector provided on KONA LS card endplate and on optional KL-Box. 9-pin D-connector pinout is as follows:

1 GND
2 RX-
3 TX+
4 GND
5 No Connection
6 GND
7 RX+
8 TX-
9 GND
Shell GND

Index

Symbols

.pkg 29

Numerics

10-bit video 63

48kHz audio 2

8-bit Versus 10-bit Video 63

8-channel 24-bit 48kHz AES 2

9-pin D 2

9-pin D-connector 2

A

A/V Devices 52

AES audio 2

AES/EBU 28

AES/EBU Audio Inputs 12

Analog 4 Channel Balanced/Unbalanced Audio 12

analog component 42, 45

analog composite 42, 45

Analog Format 42, 45, 46

Analog monitor output 12

Analog Out Screen 42

Analog Out Screen Settings 42, 45, 46

Apple Support 67

aspect ratio 54

ATA 6

ATA/IDE 7

Audio 2, 1

Audio Input 40

audio input/output 25

Audio Inputs And Outputs 12

Audio Mapping 58

Audio, Monitor 45

Audio/Video Settings 49

Audio/Video Settings Menu 51

B

Balanced 12

Bars and Tone, sample FCP project 60

Betacam 13

Black 44

black burst 13

Black Level 45, 46

black-level 42

Block Diagram Screen 36

Blue 37

BNC Connectors 11

BNC connectors 11

BNCs for Audio 26, 27

Box 3

Box Contents 20

Browser window 60

C

Cable Connections 9, 25

Cable connector descriptions 11

cables, K-Box 9

cables, set-up diagrams 20

cables, what's included 20

Cabling the System 25

camcorders 12

capacity 8

Capture Preset 51

CD 3

CD, KONA 2 Software 3

CD-ROM 28

Chassis 3

Chassis Connections 28

Checking the System 60

codec settings 54

Color Meanings, Control Panel 37

Component Analog Video Out 27

Component settings 42

Component video 12

Component/Composite 12

composite output 42, 45

Composite settings 42

Composite video 12

Configuration 29

configuring output timing 43

Connector Descriptions 11, 12

Connectors 11

connectors 25

Control Panel Basics 36

Control Panel Presets 49

Control Panel, AJA Software 3

Control Panel, KONA 2 35

Control Panel, Tabbed Screens 38

Control Screen 43

Control Screen Settings 43

Conversion Icons, Control Panel 37

customer service 65

D

data protection 8
DB9 12, 27
Default Kona Output 43
Device Control Preset 52
Digital Out Screen 42
Digital System 27
Disk Storage Solutions 6
Disk Utility 8
drivers 28
Drop Frame 58
DV (DV25) 17
DV50 17
DVCPProHD 17

E

Easy Setup (as listed in FCP Pulldown) 51
Easy Setups 49
Easy Setups Menu 49
EBU N10 13
editing timebase 53
embedded audio 2

F

Factory Easy Setups 50
Features 6
features 2
Features, KONA 2 software 3
Fibre Channel 6
Field dominance 54
Final Cut Pro 4 3, 5, 35
Final Cut Pro and KONA 2 35
Final Cut Pro menu 49
Final Cut Pro™ 3
Final Cut Pro™ support 3
Format Screen Settings 41
format, primary 13
format, secondary 36
Formats and Transfer Rates/Storage Table 8
Formats Screen 41
formats, mixing and matching 18
Frame Rate 58
Frame Size 56
Frame size 54
Framebuffer 37
Freerun 44

G

G4 5
G5 24
Genlock 44
Genlock and Your System 34
Getting Help 66
Green 37

H

hard drives 7
Hardware 2
hardware and software requirements 4
Hold Last Application 44
hot-swap 8
Hours of Storage 8
house reference 13
house reference sync 27
house sync 34

I

Icons 37
Icons, Control Panel 37
Info Screen 48
Input Pass through 43
Input Screen 38
Input Screen Settings 39
Input/Output 37
Installation Overview 19
Installation Software CD-Rom 3
Installer Screen 30
Installing Io Software 28
Installing the KONA 2 Card 23
Installing the KONA LSe 21
Introduction, KONA 2 1
IRE 45

K

K-Box 9
K-Box connector descriptions 11
K-Box, Front and Rear 11
KONA 2 Control Panel 35
KONA 2 Software 28
KONA 2 will synchronize program video 44

L

Limitations 6
Lock Input Audio Gain To Unity 45

Log On Authenticate Prompt 29
LTC 58

M

Machine Control 12
machine control 2
machine control parameters 57
Machine Control, pinout 2
Macintosh Desktop 43
Macintosh Desktop extension 43
Manual 13
minimum hardware and software requirements 4
minimums 5
Mirroring 7
Mixing and Matching Formats 18
Monitor Audio 45, 46
Monitor Out 12

O

Operating System 5
optional K-Box 9
OS X installer files 29
OS X, version 10.25 5
output default, setting 43
output video black 44

P

packaging 4
Parity 7
PCI Slot Detail 24
PCI-Express slots 21
PhotoJPEG 17
pinout, RS-422 D-connector 2
Pixel aspect ratio 54
playback device 59
Post-roll 58
Pre-roll 58
Presets 49
presets 49
Presets, KONA 2 Control Panel 49
Primary Format 37
Primary format 13
Print-to-tape 59
problem symptoms 65
Problems, what to do 65
problems, what to do if you encounter 65

Q

QuickTime Audio Settings 57
QuickTime video 54
QuickTime Video Settings 56
QuickTime™ Drivers, AJA KONA 2 3

R

RAID 6, 7, 8
RAID 0 7
RAID 1 7
RAID 5 7
RAID 50 8
RAID controller 23
RAIDs 7
RCA connector pair, K-Box configuration 45
rear panel 11
Recommended System Requirements 5
Red 37
Ref In 44
Ref Loop 27
Reference Video 13
Requirements 5
Requirements, System 4
RGB 13
RP 188 definition 48
RP-188 47
RP-188 Timecode 47
RS422 12, 57
RS-422 Control Port 2
RS-422, Sony 9-pin protocol. 9-pin D-connector pinout 2

S

sample rate 54
Sample rate conversion 3
Save Preset.. 49
Scenarios, workflow 15
SCSI RAID 6, 7
SDI cables 28
SDI embedded audio 2
SDI Input and Outputs 12
Sequence Preset 51
Sequence window 60
set up 19
Settings 49
shipping 21

- Shipping Box Contents 4
 - Slot Detail 24
 - SMPTE protocol 12
 - SMPTE RP 188 48
 - snapshot, Control Panel settings 49
 - Software 3
 - Software CD 29
 - software files that have been installed 48
 - Software For Striping 8
 - Software License Agreement Screen 31
 - Software on a PowerMac G4 or Xserve Server 28
 - software requirements 4
 - software updates 66
 - software, 3rd-party 35
 - Sony 12
 - Standard Cables 9
 - Storage 5
 - Storage capacity 8
 - Storage Methods 5
 - Storage Requirement Table 8
 - Storage Solutions 6
 - Striping 7
 - Striping data 7
 - Support 66
 - support 66
 - Support, 3rd-party software 3
 - Symptoms and remedies 65
 - Symptoms, problem 65
 - sync generator 13
 - synchronize program video 44
 - synchronizing other video equipment 13
 - system configuration, Control Panel 36
 - System Connections 28
 - system interconnections 27
 - System software 29
- T**
- Tabbed Windows 38
 - Time Source 58
 - timebase 54
 - Timecode 58
 - Timecode Offset 48
 - Timecode Screen 47
 - Timecode Screen Settings 47
 - Timing adjustment, Control Panel 44
 - Transfer Rate 8
- Transfer Rate Table 8
- Troubleshooting 65
- troubleshooting 65
- typical system interconnections 27
- Typical Workflows 16
- U**
- Uncompressed 10-bit 18
 - Uncompressed 8-bit 17
 - uncompressed media 5
 - unpack 3
 - Unpacking 20
 - Up (Conversion) 42
 - Updating Software 66
 - user and password 30
 - User Bits, RP-188 47
 - Using K-Box 11
 - Utility, disk 8
- V**
- video and audio input/output connections 25
 - Video Format 41
 - Video Input 39, 1
 - Video Monitor 27
 - Video Output 1
 - video path 37
 - video processing properties 54
 - Video/Audio connections 25
 - VITC 58
 - VTR 28, 57
 - VTR RS-422 Control Port 12
 - VTRs, 12
- W**
- Workflow 15
 - Workflow General Notes 18
- X**
- Xserve and Xserve RAID 6
 - Xserve RAID 6, 8
- Y**
- Y/R-Y/B-Y 13
 - Yellow 37
 - YPbPr 13
 - YUV 13