

### 75Ω BNC Jack Plug

Model	Suitable Cable	Boot	Die Set
BCJ-C4	RG-59 B/U, LV-61S, Belden 8241, 8279, 88241	CB25	TCD-4CA TCD-451CA

•Standard package (20pcs)

- 1.1 or less VSWR up to 1.5GHz, 1.2 or less up to 2.4GHz.
- Beryllium copper (gold plated) is used on the center contact for its superior spring characteristics. (Center contact is soldered.)

Be sure to use the Canare crimping tool for installing connectors on cables.

### 75Ω BNC Extension Adapter

Model	Description
BCJ-J	Jack to Jack

•Standard package (20pcs / 100pcs)

- Beryllium copper is used on the center contact for its superior spring characteristics.
- 1.1 or less VSWR up to 2GHz. <Fig. 1>

### 75Ω BNC Termination Plugs

Designed for true 75Ω termination

Model	Description
BCP-TA	Standard 75Ω Termination (2.0GHz Type)

•Standard package (20pcs / 100pcs)

- Includes 1/4 watt resistance.
- 1.1 or less VSWR up to 2GHz. (Up to 1GHz for BCP-PT) <Fig. 2>

### BNC Dust Caps

Model	Description
BCJ-DC	Polyethylene (Black)

•Standard package (20pcs / 100pcs)

- Protects unused BNC receptacles from dirt and dust.

### 75Ω N Solder Plug

Model	Suitable Cable
NCP-H8HD	L-8CHD

•Standard package (1pc)

- Gold plating on the contact pin prevents deterioration, even after years of use.
- 1.1 or less VSWR up to 2GHz. <Fig. 3>
- Solder type

Tools required: 17mm and 21mm wrenches

**Caution:** The connecting section of the N connector uses a shape that conforms to the IEC169-16's 75Ω impedance standard. Note that the 50Ω N and other connectors that do not conform to this specification can not be connected.

### 75Ω N to BNC Adapter

Model	Description
NCJ-BCJR	N (F) - BNC (F)

•Standard package (1pc)

- Beryllium copper (gold plated) is used on the center contact for its superior spring characteristics.
- 1.1 or less VSWR up to 2GHz. <Fig. 4>
- Panel mountable as well. For isolation from the panel, use Canare isolation bushing IU-7/16.



BCJ-C4

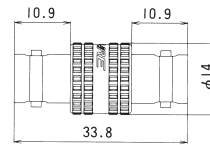

BCJ-J

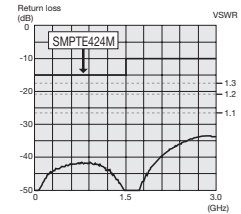
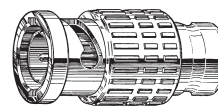

Fig.1 Return loss for BCJ-J



BCP-TA

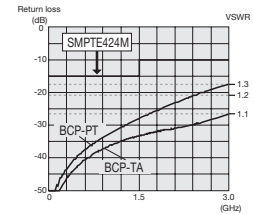
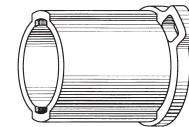
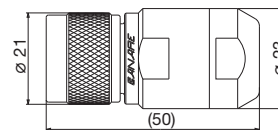

Fig.2 Return loss for BCP-PT, BCP-TA



BCJ-DC



NCP-H8HD

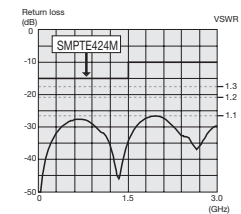
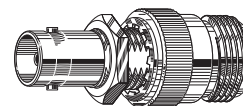

Fig.3 Return loss for NCP-H8HD



NCJ-BCJR

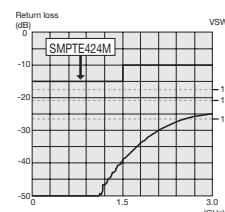
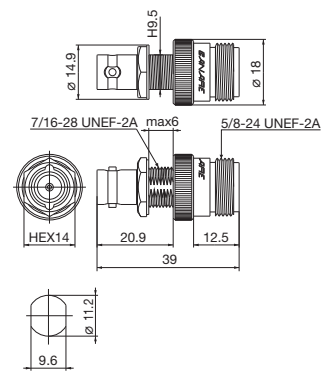

Fig.4 Return loss for NCJ-BCJR



Panel Hole Dimensions