

9550

3G Video Processing Frame Sync

The 9550 HD Processing Frame Sync accepts a 3 Gb/s or 1.5 Gb/s high definition video or standard definition video signal for processing, synchronization and timing.

Flexible Synchronization

An infinitely adjustable timing system genlocks to your house reference. The 9550 genlocks to either composite video (PAL or NTSC) or to Tri-Level Sync. The module can lock to the frame's master reference or reference can be connected directly to the module's external reference BNC. The serial output timing can be set anywhere within a frame of the selected input reference, which can be the module's external BNC reference or the frame's master timing reference.

Upon loss of signal, the 9550 provides freeze frame or black until the signal is recovered. In freeze mode, audio can be muted or passed as desired.

Uncompromised Pictures

The HD or SD SDI input is carried at full, uncompressed bandwidth throughout the entire module.

Complete Proc Amp Functions

The 9550 has a full-featured Proc Amp for adjustment of every signal parameter. Proc controls include Video and Chroma Gain, NTSC-style hue rotation, Black Balance, and Pedestal.

Audio Support

The 9550 includes a full-featured, sixteen-channel audio mixer. The channel swap and shuffle capability allows you to completely rearrange and remix audio channels. It provides precise control over audio level, with up to 12 dB of gain to compensate for low level sources. Delay is adjustable up to one second. The audio mixer can be used for embedded audio and for audio sourced from the AES or analog inputs. The 9615 AES and analog audio I/O software key option is required if you want to use the AES or analog inputs and outputs. The 9615 provides four AES input/output ports for eight channels of I/O and also provides four channels of analog audio I/O.

Dolby and AC-3

The 9550 can be fitted with Dolby and AC-3 encoding and decoding options. The 7615 decoding option can be fed from either an AES input or an AES stream disembedded from the incoming SDI signal. The resulting discrete surround signals are then selectable as inputs to the sixteen channel mixer/shuffler.

The 7630 Dolby encoder is fed from selected outputs of the sixteen channel mixer/shuffler. The resulting encoded bitstream can be output both on an AES output and embedded into the SDI output.

LevelTrack™ Audio Loudness Control AGC Software and Compliance Options

The 9670 LevelTrack Audio Loudness Control AGC software key can be added as an option. LevelTrack provides control for keeping audio levels consistent in program material.

The 9690 Audio Compliance and Monitoring Software can be added for compliance verification and archiving.

Total Control

Every function and parameter on the 9550 can be controlled from an Avenue Touch Panel or the Avenue PC Control Application. Memory registers can be used to save the complete configuration of the module, making it easy to change instantly between different configurations.

Features

- **3G, HD or SD SDI I/O**
 - **Full-featured Frame Synchronizer**
 - **Comprehensive Proc Amp controls**
 - **Color correction**
 - **External genlock reference input**
 - **Internal Color Bar Generator**
 - **Passes embedded audio**
 - **AES option for 4 streams/8 channels**
 - **Analog audio I/O option**
 - **Data mux and demux as per SMPTE 337M**
 - **Dolby encoding and decoding options**
 - **Audio Loudness Control AGC option**
 - **Memory registers**
-

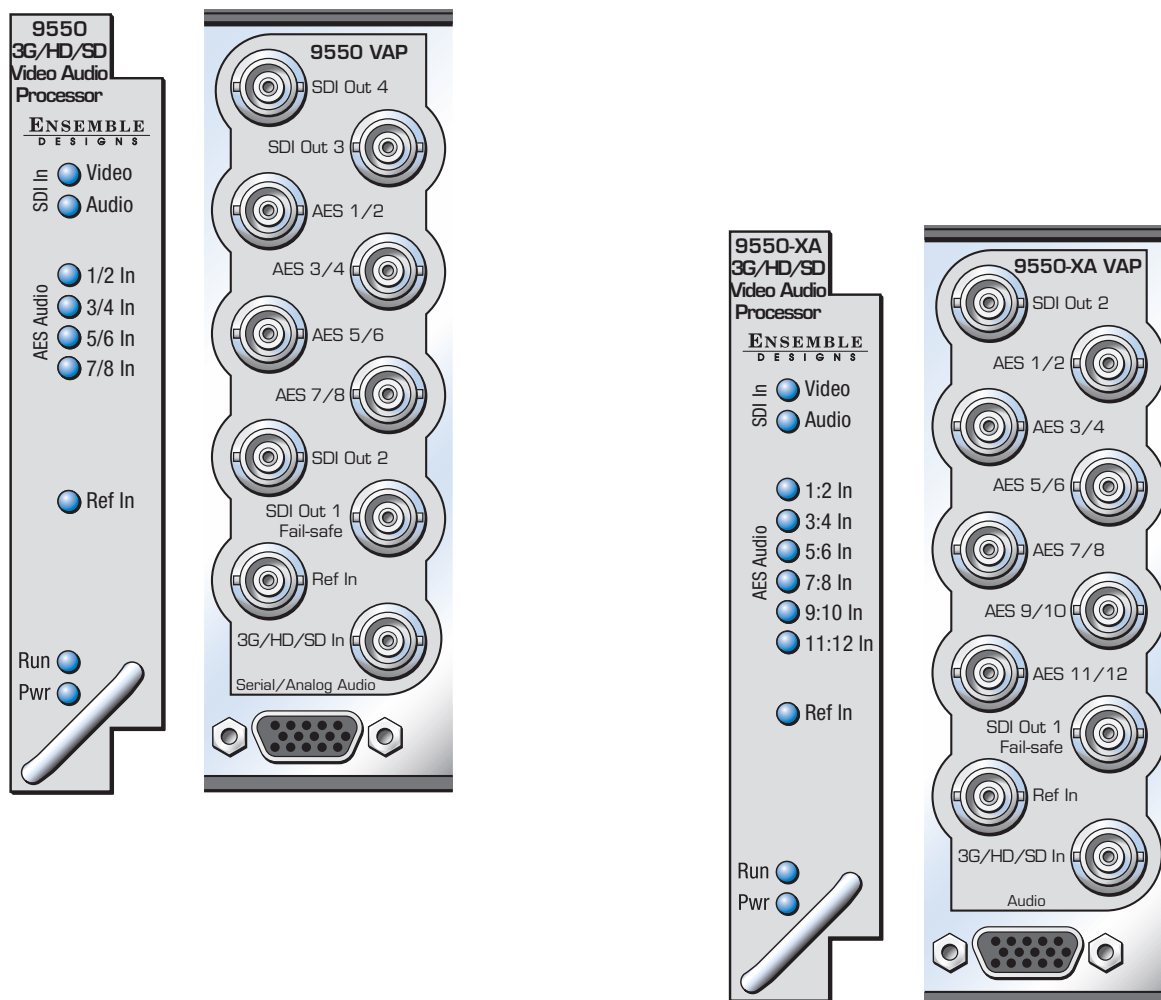

Order Info

9550	3G/HD/SD Video Processor module
9550-XA	3G/HD/SD Video Processor module with extra audio outputs XA configuration provides 12 channels of AES I/O and 2 SDI outputs
7615	Dolby E, Dolby D, AC-3 Decoder sub module and software key option Dolby processing options incur 1 frame of delay
7630	Dolby E Encoder sub module and software key option Dolby processing options incur 1 frame of delay
7635	Dolby D/AC-3 Encoder sub module and software key option Dolby processing options incur 1 frame of delay
9615	AES, analog audio, and data I/O software key option
9670	LevelTrack Audio Loudness Control AGC software key option
9690	Audio Compliance and Monitoring Software

9550

3G Video Processing Frame Sync

Input

Number	One
Signal Type	HD Serial Digital 1.485 Gb/s, SMPTE 274M, 292M or 296M HD Serial Digital 2.97 Gb/s, SMPTE 424M, 425M SD Serial Digital 270 Mb/s, SMPTE 259M
Impedance	75 Ω
Return Loss	>15 dB DC to 1.5 GHz
Max Cable Length	270 Mb/s 300 meters Belden 1694A 1.485 Gb/s 100 meters Belden 1694A 2.97 Gb/s 70 meters Belden 1694A
Automatic Cable Input Equalization	

Standards Supported

1080i 50, 59.94 or 60 Hz, SMPTE 274M -4,5,6
720p 50, 59.94 or 60 Hz, SMPTE 296M -1,2,3
1080p 50, 59.94 Hz, SMPTE 424M, 425M, Level A
625i 50, 525i 59.94
Data, SMPTE 337M

Output

Number	Four (one fail-safe bypass)
Signal Type	HD or SD Serial Digital, follows input
Impedance	75 Ω
Return Loss	>15 dB DC to 1.5 GHz
Delay	Up to 8 frames

Reference Input

Number	One external (modules BNC) One internal (frame master ref BNC)
Signal Type	PAL or NTSC composite video or Tri-Level Sync
Return Loss	>40 dB (applies to external ref input)

AES/EBU Digital Inputs (requires 9615 option)

Number	Four (total of eight channels) selectable as inputs or outputs
Type	AES3id or data, SMPTE 337
Connector	Coaxial, 75 Ω
Bit Depth	20 and 24 bit
Sample Rate	30 kHz to 100 kHz (sample rate converted internally to 48 kHz)
Crosstalk	<144 dB
Dynamic Range	>144 dB
Reference Level	-18 or -20 dBFS (selectable)

AES/EBU Digital Outputs (requires 9615 option)

Number	Four (total of eight channels) selectable as inputs or outputs
Type	AES3id or data
Connector	Coaxial, 75 Ω
Bit Depth	20 and 24 bit
Sample Rate	48 kHz, synchronous to video output
Reference Level	-18 or -20 dBFS (selectable)

Analog Audio Inputs (requires 9615 option)

Number	Four, selectable as inputs or outputs
Type	Balanced
Connector	15 pin D
Impedance	>15K Ω
Maximum Input Level	24 dBu
CMRR	>60 dB, 20 Hz to 10 KHz
Quantization	24 bits, 128 x oversampled
Sample Rate	48 KHz
Reference Level	-10 dBu or +4 dBu
Frequency Response	\pm 0.1 dB, 20 Hz to 20 KHz
Crosstalk	<106 dB
Dynamic Range	>106 dB

Analog Audio Outputs (requires 9615 option)

Number	Four, selectable as inputs or outputs
Type	Balanced, transformerless
Connector	15 pin D
Impedance	30 Ω
Maximum Output Level	24 dBu
Resolution	24 bits, 128 x oversampled
Reference Level	-10 dBu or +4 dBu
Frequency Response	\pm 0.1 dB, 20 Hz to 20 KHz
Crosstalk	<106 dB
Dynamic Range	>106 dB

Dolby Metadata Inputs/Outputs (requires 9615 option)

Signal Type	Dolby metadata, RS-422, RS-485
Number	Four, selectable as inputs or outputs, share with analog audio I/O
Connector	HD-15, balanced

Embedded Output (In SDI Outputs)

Group Assign	Cascade or replace
Channels	Sixteen
Bit Depth	24 Bit

General Specifications

Power Consumption	10 watts
Temperature Range	0 to 40°C ambient (all specs met)
Relative Humidity	0 to 95%, noncondensing
Altitude	0 to 10,000 ft

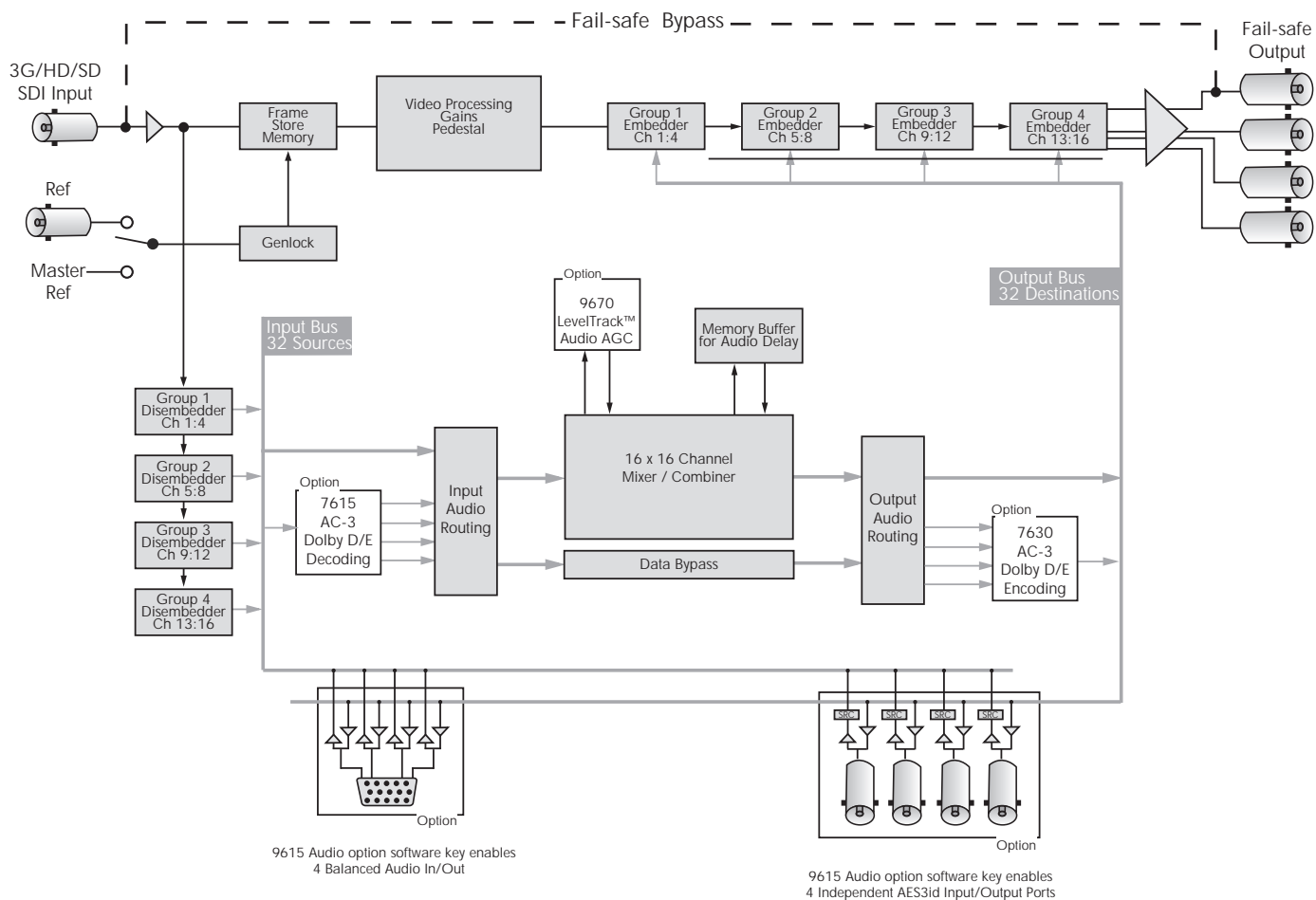

Above, block diagram for the 9550 3G/HD/SD Video Processor module

Alternately, for 12 channels of AES I/O and 2 SDI outputs, order the 9550-XA