

**1. CONDUCTOR**

Material: Tin Plated Copper  
Construction: See Table 1

**2. INSULATION**

Material  
Layer 1: Irradiation Crosslinked Polyolefin  
Layer 2: Irradiation Crosslinked PVDF  
Wall thickness  
Layer 1: 0.006" nominal  
Layer 2: 0.003" nominal  
Diameter: See Table 1  
Color: See Table 3

**3. PAIR**

Two (2) Insulated Conductors together

**4. CABLE**

# Components: See Table 1  
Lay: 14 x Cabled Core OD  
Fillers: Optional

**5. BRAID SHIELD**

Material: 36 AWG Tinned Copper  
Coverage: 85% min  
Barrier Tape: Optional

**6. JACKET**

Material: Irradiation Crosslinked PVDF  
Thickness: 0.009" nominal  
Color: White  
Marking: JUDD WIRE FLEXRAD 44 M TP #XX  
AWG ZZ/ZZ 150°C 600V (YYYY)

M – Denotes Number of components  
XX – Denotes AWG Size  
ZZ/ZZ – Denotes Conductor Standing  
YYYY – Denotes Year of Manufacture

**7. PHYSICAL CHARACTERISTICS**

Temperature rating: 150°C  
Voltage rating: 600V  
Weight: See Table 1

**8. PERFORMANCE PROPERTIES – AS81044/12**

Mechanical  
Elongation 150%, min  
Tensile Strength 2500 psi, min  
Concentricity 70%, min  
Wicking 2.25", max  
Bend Test See Table 2 for Mandrel Requirements  
Print Durability 125 Cycles, 500g  
Mandrel Wrap Test See Table 2 for Mandrel Requirements  
No Cracks, Pass Wet Dielectric Test

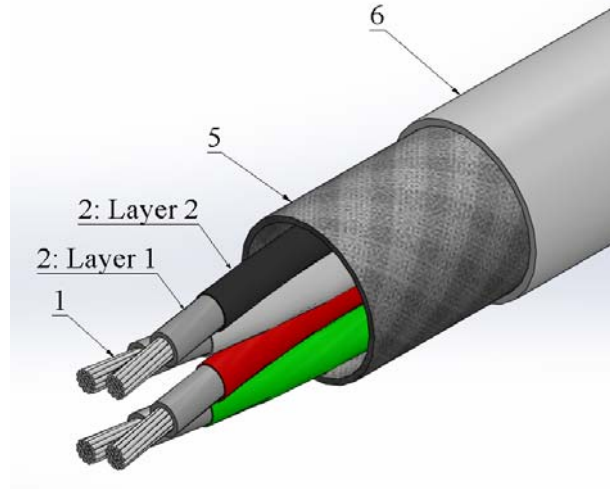

**PERFORMANCE PROPERTIES (Con't)**

Electrical  
Impulse Dielectric Test 6.0/8.0 kV<sub>ac</sub>  
Wet Dielectric Test (5 hrs @ 25°C)  
5% NaCl Solution, 2500 V, 5 min  
Insulation Resistance 5000 MΩ/kft, min  
Direct Current Resistance @ 20°C See Table 1  
Surface Resistance 500 MΩ·in, Initial and Final Readings, min  
Spark Test 1500 V  
Thermal  
Shrinkage (6 hrs @ 300°C) 0.125 in, max  
Life Cycle (168 hrs @ 200°C)  
No Cracks, No Conductor Pitting  
Accelerated Aging I (6 hrs @ 300°C)  
No Cracks, No Conductor Pitting  
Pass Wet Dielectric Test  
Accelerated Aging II (6 hrs @ 225°C)  
Print shall Remain Legible  
Cold Bend (4 hrs @ -65°C)  
See Table 2 for Mandrel Requirements  
No Cracks, Pass Wet Dielectric Test  
Thermal Shock Resistance  
High Temperature 30 min @ 150°C  
Low Temperature 30 min @ -55°C  
Number of Cycles 4  
Change in Measurement 0.060", max  
Humidity Resistance 5000 MΩ/kft, min  
Blocking (24 hrs @ 225°C)  
Adjacent Wire Shall not Stick  
Flammability 60° Angle  
Maximum Burn Time 30 sec  
Maximum Char Length 3.0"  
Tissue Paper No Flame



**JUDD WIRE INC.**  
124 Turnpike Road  
Turners Falls, MA 01376  
(413) 863-4357

Date	Rev	By	Appr'd	ECN
06/20/13	--	EM	GT	---
09/25/13	A	EM	GT	13-1430
Customer Approval:				

Description: <b>TP, TPC, FLEXRAD 44, BSH, XLPVDF 150°C, 600V</b>	
Specification Number: <b>JW1507-13</b>	Page: 1 of 2

Smoke Test (15 min @ 200°C)  
No Indication of Visible Smoke

Turbine Fuel

5%

Chemical

Immersion Tests (20 hrs @ 50°C)  
No Cracks, Pass Wet Dielectric  
OD Increase, Max

Lubricating Oil 5%  
Hydraulic Fluid 5%  
Isopropyl Alcohol 5%

**9. REFERENCE SPECIFICATION**

SAE AS81044  
SAE AS81044/12

Table 1 - Construction Details

# Pairs	Size	Stranding	DCR Ω/kft, max	Insulated OD			Finished OD, in			Weight lbs/kft, nom
	AWG	#S/AWG		min	nom	max	min	nom	max	
2	20	19/32	9.88	0.053	0.055	0.057	0.209	0.229	0.249	40.1
2	16	19/29	4.91	0.071	0.073	0.075	0.266	0.286	0.306	56.1

Table 2: Test Requirements

Size (AWG)	Bend Test Requirements				
	Mandrel Diameter (in)			Test Load (lbs)	
	Life Cycle and Acc. Aging Test	Cold Bend Testing	Wrap Test	Life Cycle and Acc. Aging Test	Cold Bend Test
24	0.50	0.50	0.250	0.38	0.50
22	0.75	0.75	0.250	0.36	1.00
20	0.75	1.00	0.250	0.36	1.00
18	1.00	1.50	0.375	0.50	1.00
16	1.00	1.50	0.375	0.50	1.00
14	1.50	2.00	0.500	1.00	3.00
12	2.00	2.00	0.500	1.00	3.00

Table 3: Color Code

Component #	Pair #	Color
1	1	Black
2	1	White
3	2	Red
4	2	Green



**JUDD WIRE INC.**  
124 Turnpike Road  
Turners Falls, MA 01376  
(413) 863-4357

Description:

**TP, TPC, FLEXRAD 44, BSH,  
XLPVDF 150°C, 600V**

Specification Number:

**JW1507-13**

Rev:  
**A**

Page:  
2 of 2