

NOTICE TO ALL PERSONS RECEIVING THIS DRAWING
 THIS DRAWING IS ONLY CONDITIONALLY ISSUED, AND NEITHER RECEIPT NOR POSSESSION THEREOF CONFERS OR TRANSFERS ANY RIGHT IN, OR LICENSE TO USE THE SUBJECT MATTER OF THE DRAWING OR ANY DESIGN OR TECHNICAL INFORMATION SHOWN THEREON. NOR ANY RIGHT TO REPRODUCE THIS DRAWING OR ANY PART THEREOF EXCEPT FOR MANUFACTURE BY VENDORS FOR HARCO LABORATORIES INC AND FOR MANUFACTURE UNDER THE CORPORATION'S WRITTEN LICENSE. NO RIGHT TO REPRODUCE THIS DRAWING IS GRANTED UNLESS BY WRITTEN AGREEMENT WITH OR WRITTEN PERMISSION FROM HARCO LABORATORIES INC

ECP	ECR	REL DATE	REV. LET.	REVISION	REV. BY	CHK BY	APPROVED BY		
							DE	M.E.	QE
		5-17-11	B	DCRA 23597-014B, 1) REPLACED "HEAD ON" VIEW WITH TWISTED VIEW 2) NOTE 1 - ADDED MIL-C-27500 SPEC 3) REPLACED ALL INSTANCES OF ALUMEL WITH KN (AL) AND ALL INSTANCES OF CHROMEL WITH KP (CR) 4) ADDED NOTES 5 & 6	RFP	RFP	AJH	GW	AAH
		01-15-13	C	DCRA 23597-014C. - 1.) IN NOTE 1, SPEC WAS MIL-C-27500, ADDED "RIGHT HAND LAY.....LENGTH". 2.) REMOVED NOTE 3. 3.) ADDED NOTE 7. 4.) 36 AWG NPC BRAID 90% COVERAGE WAS "SCREEN - NICKEL PLATED COPPER. 5.) PTFE WAS TEFLON, AND ADDED .010 THICK NOMINAL, 2 PLACES. 6.) JACKET CALL-OUT WAS " JACKET - TEFLON EXTRUDED OR TAPE WRAPPED".	JAV	JAV	AJH	GW	AAH

NOTES:

- (C1) (B2) 1. ALL CABLES TO BE LAID UP & SHIELDED IN ACCORDANCE WITH MIL-DLT-27500. WIRES MUST BE TWISTED IN ACCORDANCE WITH MIL-C-27500. RIGHT HAND LAY 1 1/4" NOMINAL LAY LENGTH.
- (B3) (A) 2. KN (AL) & KP (CR) CONDUCTORS TO BE TYPE K THERMOCOUPLE GRADE MATERIAL PER ANSI MC96.1 .
- (C2) 3. REMOVED.
- 4. CABLES TO BE SPOOLED WITH INCREMENTAL LENGTHS NOT SHORTER THAN 250 FEET.
- (B4) 5. DO NOT PURCHASE FROM THERMAL WIRE & CABLE CORPORATION DUE TO PAST QUALITY ISSUES.
- (B4) 6. ACCEPTABLE TRADE NAMES FOR OUTER JACKET TEFLON THAT MAY BE USED:
 - PTFE (POLYTETRAFLUOROETHYLENE)
 - FEP (FLOURINATED ETHYLENE PROPYLENE)
- (C3) 7. MUST BE PURCHASED FROM APPROVED SUPPLIERS:

RSCC AEROSPACE (P/N HAR-23597-014 20 2C 7S KP/KN WHT JACKET)
 OR
 QUIRK WIRE (P/N T/CK207-2 CSFJ-NPC)

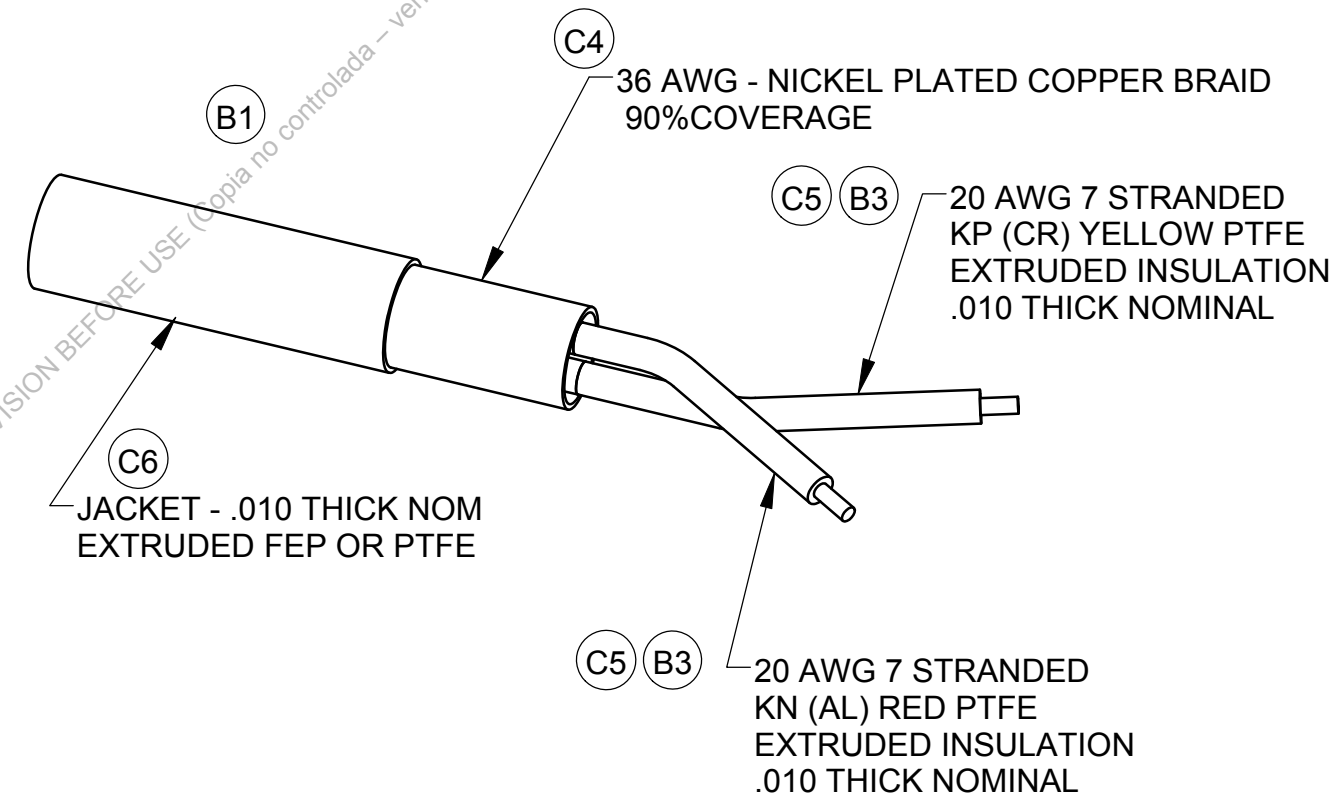

23597-014
 PART NUMBER

UNLESS OTHERWISE SPECIFIED: DIMENSION ARE IN INCHES. TOLERANCES ARE:		APPROVALS	DATE
DECIMALS:	±.010	DRAWN BY: JRC	12-21-04
FRACTIONS:	±1/32	CHECKED BY: JRC	12-21-04
ANGLES:	±2°	D.E.: PC	12-22-04
ALL DIAMETERS	±.010	M.E.: JZ	12-22-04
BREAK EDGES:	.005-.020	Q.A.: AJH	12-23-04
FILLET TO BE:	.005-.020		
SURFACE FINISH:	125/		

LABORATORIES, INC.
 BRANFORD, CT 06405-0010

TITLE
**CABLE, THERMOCOUPLE,
 TYPE K, 20 GA SJPR, (M27500)**

MATERIAL SPEC	FINISH SPEC	SIZE B	CAGE CODE 00060	DRAWING NUMBER 23597-014	REV. C
-	-	SCALE NONE	SHEET 1 OF 1		