

NOTICE TO ALL PERSONS RECEIVING THIS DRAWING  
 THIS DRAWING IS ONLY CONDITIONALLY ISSUED, AND NEITHER RECEIPT NOR POSSESSION THEREOF CONVEYS OR TRANSFERS ANY RIGHT IN, OR LICENSE TO USE THE SUBJECT MATTER OF THE DRAWING OR ANY DESIGN OR TECHNICAL INFORMATION THEREON. NO RIGHT TO REPRODUCE THIS DRAWING OR ANY PART THEREOF EXCEPT FOR MANUFACTURE BY VENDORS FOR HARCO LABORATORIES, INC. AND FOR MANUFACTURE UNDER THE CORPORATION'S WRITTEN LICENSE. NO RIGHT TO REPRODUCE THIS DRAWING IS GRANTED UNLESS BY WRITTEN AGREEMENT WITH OR WRITTEN PERMISSION FROM HARCO LABORATORIES, INC.

ECP	ECR	REL DATE	REV. LET.	REVISION	REV. BY	CHK BY	APPROVED BY
		6-21-11	D	DCRA 24854D. 011 IN TITLE BLOCK VENDOR 1 WAS VENDOR 2. SHEET 2 D2) CARLISLE/TENSOLITE WAS TENSOLITE. SHEET 3 IN TITLE BLOCK VENDOR 3 WAS VENDOR 2. ADDED SHEET 4.	RVA	RVA	RCG SMA WDG
		10-13-11	E	DCRA 24854E. ON SHEET 4 E1, IN TENSILITE P/N /18004LT WAS /18004LT. E2, UPDATED OVERALL CABLE NOTE. E3, NOTE F WAS COMBINED WITH NOTE E. E4, IN NOTE 6 AS-85485 WAS MIL-C-85485 & .015 OHMS PER METER WAS 0.01 OHMS PER METER. ADDED FOR 24854-007 THROUGH 24854-013. E5, IN SOURCE OF SUPPLY TABLE P/N -007, -008 & -009 THROUGH -013 IN THE CARLISLE P/N /18004LT WAS /18004LT. ADDED SHEET 5.	RVA	RVA	RCG SMA WDG
		11-16-11	F	DCRA 24854F. - ON SHT 4, 1.) ADDED NOTE 8. 2.) IN SOURCE OF SUPPLY CHART, NOMINAL WEIGHT COLUMN WAS CAGE NO. AND NOMINAL OD OVER JACKET COLUMN WAS NAME AND ADDRESS. 3.) Ø WAS .405 - .445 MAX NOM. 4.) Ø WAS (.547) 5.) WIRE IDENT. 10 & 11 WAS 14 & 15. 6.) WIRE IDENT 12 & 13 WAS 14 & 15. 7.) Ø WAS (.579) 8.) Ø WAS .593 - .623 NOM MAX. 9.) WIRE IDENT 12 & 13 WAS 14 & 15. 10.) Ø WAS (.547). 11.) TENSOLITE P/N WAS 20444/18004LT13. ON SHT 5, 12.) ADDED NOTE 8. 13.) WIRE IDENT. 10 & 11 WAS 14 & 15. 14.) WIRE IDENT. 12 & 13 WAS 14 & 15. 15.) WIRE IDENT. 12 & 13 WAS 14 & 15. 16.) THERMAX P/N WAS 1289-130. 17.) IN CHART, THERMAX WAS TENSOLITE.	JAV	JAV	RCG SMA WDG
		05-08-12	G	DCRA 24854G. - 1.) REMOVED NOTES 4 & 5 ON SHEETS 2 THRU 5. 2.) NOTE 6 ON SHEETS 4 & 5 CHANGED, ADDED *TRANSFER IMPEDANCE PER METER SHALL BE LESS THAN (2 * P1) * FREQUENCY * 1 (mH) / METER FOR ALL MEASURED FREQUENCIES FROM 10 MHz THROUGH 100 MHz.* 3.) ADDED NOTE TO BOTTOM OF SHEET 5. ON SHT 4, 4.) Ø WAS (.257) 5.) Ø WAS (.391) 6.) Ø WAS (.409) 7.) Ø WAS (.512) 8.) Ø WAS (.527) 9.) Ø WAS (.530) 10.) Ø WAS (.503) 11.) IN SOURCE OF SUPPLY TABLE, CHANGED VALUES FOR WEIGHT AND OD FROM NOMINAL TO MAX.	JAV	JAV	RCG SMA WDG
		02-26-13	H	DCRA 24854H. SHEET 4: 1) ADDED P/N 24854-014; 2) REVISED SOURCE OF SUPPLY TABLE; 3) DISCONTINUED P/N 24854-013; 4) REVISED NOTES 1F & 6.	WHH	WHH	RCG SMA WDG
		05-14-13	J	DCRA 24854J; 1) REVISED NOTE 6 ON SHEET 4. 2) ON SHEET 4 HARCO P/N 24854-014 REVISED TENSILITE P/N.	WHH	WHH	RCG SMA WDG

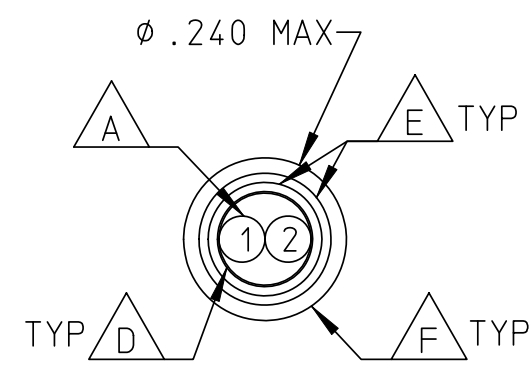

HARCO P/N 24854-000  
 JUDD P/N JW703-99 (2/20)

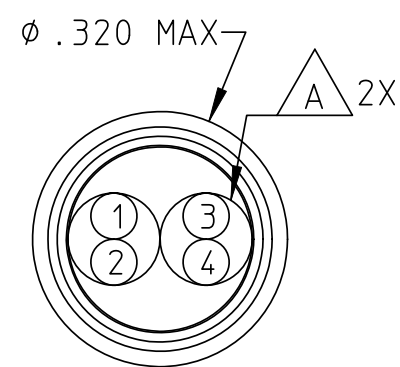

HARCO P/N 24854-001  
 JUDD P/N JW704-99 (4/20)

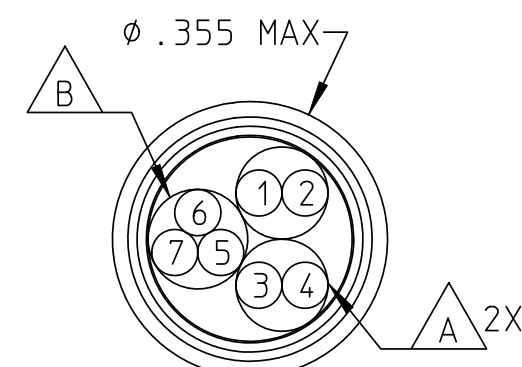

HARCO P/N 24854-002  
 JUDD P/N JW698-99 (7/20)

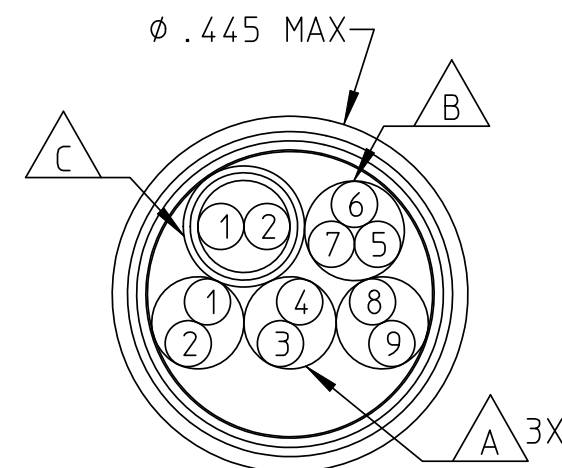

HARCO P/N 24854-003  
 JUDD P/N JW699-99 (11/20)

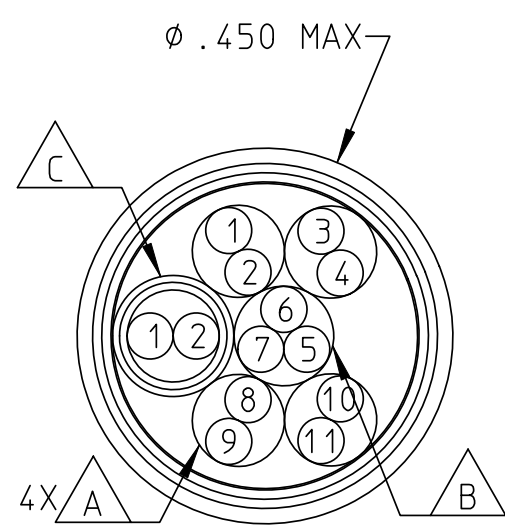

HARCO P/N 24854-004  
 JUDD P/N JW700-99 (13/20)

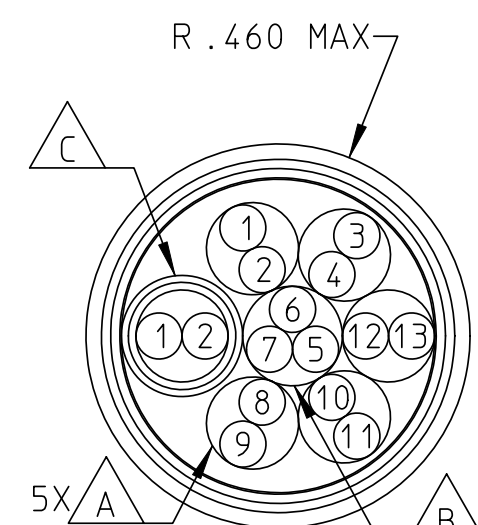

HARCO P/N 24854-005  
 JUDD P/N JW701-99 (15/20)

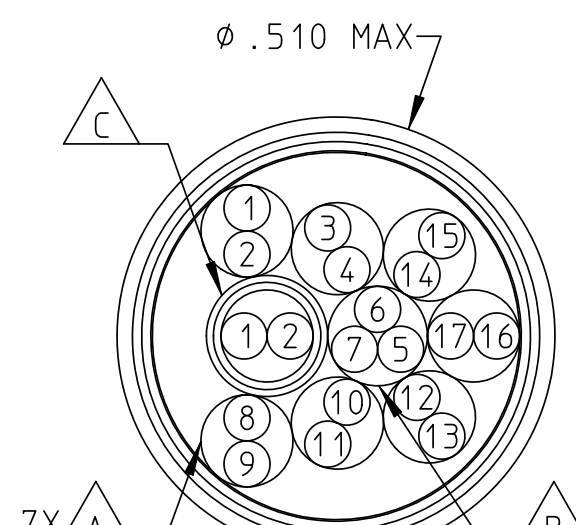

HARCO P/N 24854-006  
 JUDD P/N JW702-99 (19/20)

NOTES:

- CONDUCTOR: 20AWG 7X9/38 NICKEL PLATED HIGH STRENGTH ALLOY 135  $\pm 0.0415 \pm .001$ ; DCR 13 OHM/1000FT MAXIMUM. DIELECTRIC. EXTRUDED XLETFE; .009 MINIMUM WALL;  $0.059 \pm .002$ , COLORS OPTIONAL.
  - A TWISTED PAIR: 2 CONDUCTOR; 1.50 INCH LH LAY;  $\phi .122$  MAXIMUM.
  - B TWISTED TRIPLE: 3 CONDUCTOR; 1.75 INCH LH LAY;  $\phi .132$  MAXIMUM.
  - C SHIELDED JACKETED TWISTED PAIR: 2 CONDUCTOR; 1.75 INCH LH LAY SHIELD: 38 AWG NICKEL COPPER BRAID; 50 MICROINCHES MINIMUM NICKEL, 90% COVERAGE MINIMUM, 5 ENDS, 16 CARRIERS. JACKET: EXTRUDED XLETFE (.009 NOMINAL) .005 MIN WALL THICKNESS;  $\phi .152$  ( $\phi .164$  MAX).
  - D INNER TAPE WRAP: .004 X 10% MINIMUM OVERLAP, SKIVED PTFE.
  - E OVERALL SHIELDS: COATING THICKNES SHALL BE 40 TO 150 MICROINCHES OF NICKEL. SHIELDS SHALL BE CONTINUOUS (NO SPLICES) PER REEL. CABLE CONSTRUCTION SHALL IN ACCODANCE WITH MIL-C-27500. INNER SHIELD: 36 AWG NICKEL PLATED COPPER, 90% MINIMUM COVERAGE, 40-50 DEGREE BRAID ANGLE. OUTER SHIELD: 36 AWG NICKEL PLATED COPPER, 90% MINIMUM COVERAGE, 40-50 DEGREE BRAID ANGLE.
  - F OVERALL JACKETS: THE CABLES SHALL HAVE AN EXTRUDED YELLOW XLETFE FLEXIBLE JACKET. WALL THICKNESS = (.024 NOM, .012 MIN) THE JACKET MATERIAL SHALL BE 100% VIRGIN MATERIAL. VIRGIN MATERIAL SHALL BE NEW MATERIAL WHICH HAS BEEN THROUGH ONLY THE PROCESSES ESSENTIAL TO ITS MANUFACTURE OR APPLICATION AND HAS BEEN THROUGH THIS PROCESS ONE TIME ONLY. THE USE OF ANY RECLAIMED MATERIALS SHALL BE CAUSE FOR REJECTION. PRINT LEGEND \*JUDD P/N 12703 MO YR LOT#\*
  - G OUTER TAPE WRAP: .004" WITH A 25-50% OVERLAP, SKIVED PTFE.
- CABLES SUPPLIED TO THIS DRAWING CAN NOT BE CHANGED WITHOUT PRIOR APPROVAL OF HARCO LABORATORIES, INC.
- CABLES SUPPLIED TO THIS DRAWING SHALL BE CAPABLE OF NORMAL OPERATION AT ANY EXPOSURE TO TEMPERATURE LIMITS OF  $-75^{\circ}\text{C}$  TO  $+90^{\circ}\text{C}$ .
- CABLES SUPPLIED TO THIS DRAWING SHALL BE QUALIFIED BY SIMILARITY IN ACCORDANCE WITH BOEING SPECIFICATION S280W501.
- KEY SHIELD PERFORMANCE: WHEN TESTED IN ACCORDANCE WITH MIL-C-85485, THE TRANSFER IMPEDANCE SHALL BE LESS THAN 0.01 OHMS PER METER.
- CABLE BUNDLE SHALL BE ROUND. USE OF FILLERS CREATE ROUND BUNDLE IS ALLOWED.
- WIRE COLOR CODING: WHITE BACKGROUND WITH COLOR STRIPE IS OPTIONAL. SOLID COLORS ARE ACCEPTABLE. i.e. WHT/ORG MAY BE ORANGE. WHT/GRN MAY BE GREEN.

WIRE NO.	COLOR(S)	OPTIONAL
1	WHT	
2	WHT/BLK	
3	WHT/BRN	
4	WHT/RED	
5	WHT/GRN	
6	WHT/ORG	
7	WHT/YEL	
8	WHT/BLU	
9	WHT/VIO	
10	WHT/GRY	
11	WHT/BLK/BRN	
12	WHT/BLK/RED	
13	WHT/BLK/ORN	
14	WHT/BLK/GRN	
15	WHT/BLK/YEL	
16	WHT/BLK/VIO	
17	WHT/BLK/BLU	

SOURCE OF SUPPLY			
SUPPLIER DATA			
HARCO P/N	PART NO.	CAGE NO.	NAME AND ADDRESS
24854-000	JW703-99 (2/20)		JUDD
24854-001	JW704-99 (4/20)		
24854-002	JW698-99 (7/20)		
24854-003	JW699-99 (11/20)		
24854-004	JW700-99 (13/20)		
24854-005	JW701-99 (15/20)		
24854-006	JW702-99 (19/20)		

IDENTIFICATION OF THE SUGGESTED SOURCE OF SUPPLY HEREON IS NOT TO BE CONSTRUED AS A GUARANTEE OF PRESENT OR CONTINUED AVAILABILITY AS A SOURCE OF SUPPLY FOR THE ITEM.

SOURCE CONTROL DRAWING

UNLESS OTHERWISE SPECIFIED: DIMENSIONS ARE IN INCHES		APPROVALS		DATE
TOLERANCES ARE:		DRAWN	WAC	03-16-05
DIMENSIONS	.010	CHECKED	WAC	03-16-05
FRACTIONS	1/32	ENGR	-	
ANGLES	30, 0.10	DE	MW	03-22-05
ALL DIAMETERS	±0.010	M.E.	PC	03-30-05
BREAK EDGES	.005-.020	QA	AJH	03-29-05
FILLET TO BE	.005-.020	PREPARED UNDER CONTRACT		
SURFACE FINISH	125	FURNISHED UNDER CONTRACT		

**Laboratories, Inc.**  
 BRANFORD, CT 06405-0010  
 CABLE, 20GA, MULTI-CONDUCTOR,  
 JUMPER, FBW, VENDOR 1

MATERIAL SPEC	FINISH SPEC	PREPARED UNDER CONTRACT	SCALE	1:1	SHEET	1 OF 5

NOTICE TO ALL PERSONS RECEIVING THIS DRAWING  
 THIS DRAWING IS ONLY CONDITIONALLY ISSUED, AND NEITHER RECEIPT NOR POSSESSION THEREOF CONFER OR TRANSFERS ANY RIGHT IN, OR LICENSE TO USE THE SUBJECT MATTER OF THE DRAWING OR ANY DESIGN OR TECHNICAL INFORMATION SHOWN THEREON, NOR ANY RIGHT TO REPRODUCE THIS DRAWING OR ANY PART THEREOF EXCEPT FOR MANUFACTURE BY VENDORS FOR HARCO LABORATORIES, INC. AND FOR MANUFACTURE UNDER THE CORPORATION'S WRITTEN LICENSE. NO RIGHT TO REPRODUCE THIS DRAWING IS GRANTED UNLESS BY WRITTEN AGREEMENT WITH OR WRITTEN PERMISSION FROM HARCO LABORATORIES, INC.

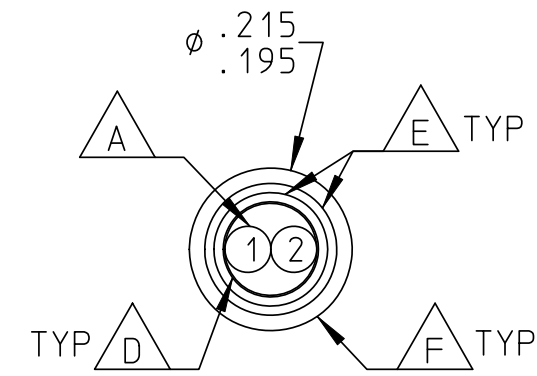

HARCO P/N 24854-000  
 TENSOLITE P/N 20444/9E004LT-2

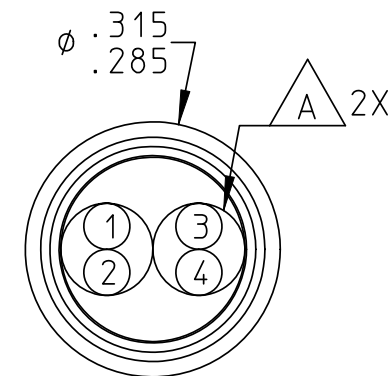

HARCO P/N 24854-001  
 TENSOLITE P/N 20444/9E004LT-4

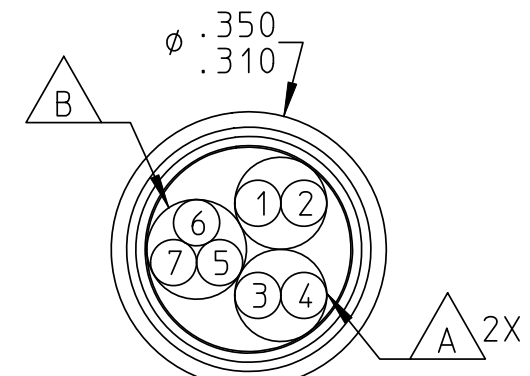

HARCO P/N 24854-002  
 TENSOLITE P/N 20444/9E004LT-7

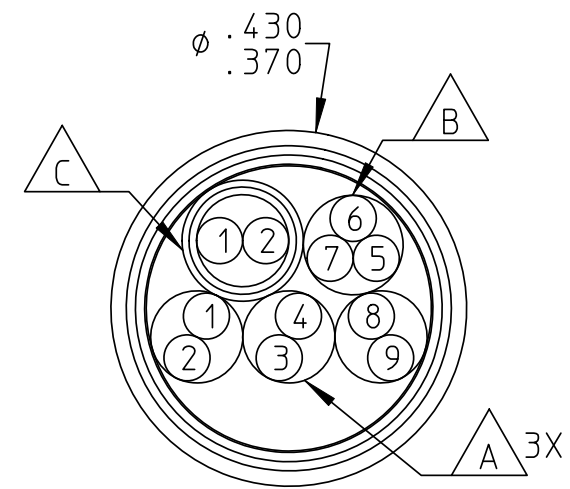

HARCO P/N 24854-003  
 TENSOLITE P/N 20444/9E004LT-11

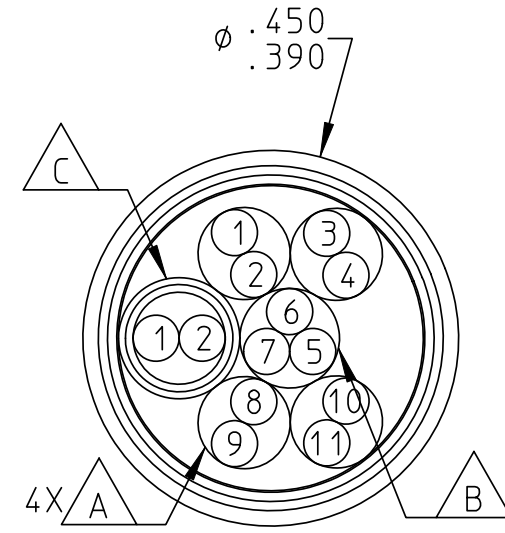

HARCO P/N 24854-004  
 TENSOLITE P/N 20444/9E004LT-13

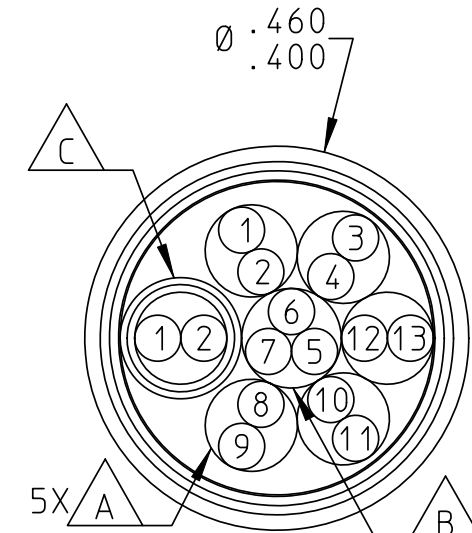

HARCO P/N 24854-005  
 TENSOLITE P/N 20444/9E004LT-15

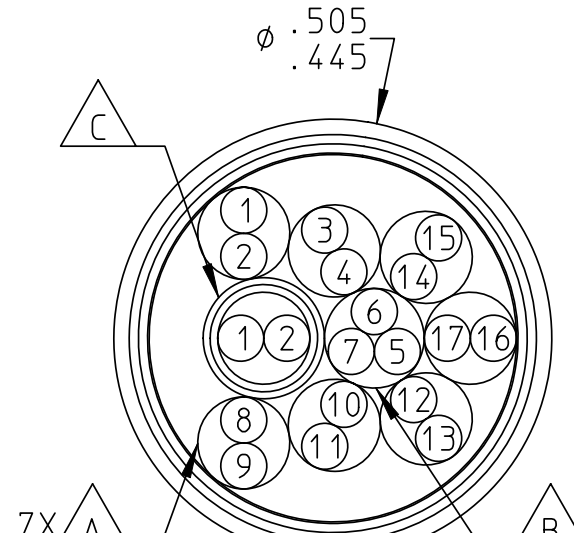

HARCO P/N 24854-006  
 TENSOLITE P/N 20444/9E004LT-19

WIRE NO.	HARCO TOP LEVEL	TENSOLITE
1	WHT	WHT
2	WHT/BLK	BLK
3	WHT/BRN	BRN
4	WHT/RED	RED
5	WHT/GRN	GRN
6	WHT/ORG	ORG
7	WHT/YEL	YEL
8	WHT/BLU	BLU
9	WHT/VIO	VIO
10	WHT/GRY	GRY
11	WHT/BLK/BRN	BLK/BRN
12	WHT/BLK/RED	BLK/RED
13	WHT/BLK/ORG	BLK/ORG
14	WHT/BLK/GRN	BLK/GRN
15	WHT/BLK/YEL	BLK/YEL
16	WHT/BLK/VIO	BLK/VIO
17	WHT/BLK/BLU	BLK/BLU

NOTES:

1. CONDUCTOR: 20AWG 65/38 NICKEL PLATED HIGH STRENGTH ALLOY 135  $\pm 0.0415 \pm .001$ ; DCR 13 OHM/1000FT MAXIMUM. DIELECTRIC. EXTRUDED PTFE; .008 MINIMUM WALL;  $0.059 \pm .002$ , COLORS AS SHOWN.

A TWISTED PAIR: 2 CONDUCTOR; 1.50 INCH LH LAY.

B TWISTED TRIPLE: 3 CONDUCTOR; 1.75 INCH LH LAY.

C SHIELDED JACKETED TWISTED PAIR: 2 CONDUCTOR; 1.25 INCH LH LAY  
 SHIELD: 38 AWG NICKEL COPPER BRAID; 50 MICROINCHES MINIMUM NICKEL, 90% COVERAGE MINIMUM.  
 JACKET: 2 LAYERS CROSSWRAP UNSINTERED PTFE .003 X 3/4 45-50% LAP BOTH WRAPS,  $0.158$  MAXIMUM.

D BINDER: PTFE TAPE .003 X 10% MINIMUM OVERLAP APPLIED AT CABLE OPERATION WITH FIBERGLASS FILLER AS REQUIRED.

E OVERALL SHIELDS: THE CABLES SHALL HAVE TWO (2) OVERALL BRAIDED SHIELDS OF #36 OR #34 AWG NICKEL COATED COPPER WITH EACH HAVING 4% COVERAGE OF NOT LESS THAN 90%. THE BRAID ANGLE SHALL BE  $40^{\circ}$ - $50^{\circ}$ . THE COATING THICKNESS SHALL BE 40 TO 150 MICROINCHES OF NICKEL. SHIELDS SHALL BE CONTINUOUS (NO SPLICES) PER REEL. CABLE CONSTRUCTION SHALL BE IN ACCORDANCE WITH MIL-C-27500.

F OVERALL JACKETS: THE CABLES SHALL HAVE A PTFE TAPE WRAP JACKET. THE INNER TAPE SHALL BE WHITE. THE JACKET SHALL BE CONSTRUCTED AS FOLLOWS:

- TAPE ONE: .004" PTFE (WHITE) - 25-50% LAP
- TAPE TWO: .003" PTFE (YELLOW) - 25-50% LAP
- TAPE THREE: .003" PTFE (YELLOW) - 25-50% LAP
- TAPE FOUR (CABLE  $0.350$ " AND LARGER): .003" PTFE (YELLOW) - 25-50% LAP

JACKET MATERIAL SHALL BE 100% VIRGIN MATERIAL. VIRGIN MATERIAL SHALL BE NEW MATERIAL WHICH HAS BEEN THROUGH ONLY THE PROCESSES ESSENTIAL TO ITS MANUFACTURE OR APPLICATION AND HAS BEEN THROUGH THIS PROCESS ONE TIME ONLY. THE USE OF ANY RECLAIMED MATERIALS SHALL BE CAUSE FOR REJECTION. THE JACKET MUST BE PRINTED WITH THE TENSOLITE PART NUMBER, CAGE CODE, AND TRACEABILITY INFO.

2. CABLES SUPPLIED TO THIS DRAWING CAN NOT BE CHANGED WITHOUT PRIOR APPROVAL OF HARCO LABORATORIES, INC.

3. CABLES SUPPLIED TO THIS DRAWING SHALL BE CAPABLE OF NORMAL OPERATION AT ANY EXPOSURE TO TEMPERATURE LIMITS OF  $-75^{\circ}\text{C}$  TO  $+90^{\circ}\text{C}$ .

G1 4. REMOVED

G1 5. REMOVED

KEY 6. SHIELD PERFORMANCE: WHEN TESTED IN ACCORDANCE WITH MIL-C-85485, THE TRANSFER IMPEDANCE SHALL BE LESS THAN 0.01 OHMS PER METER.

UNCONTROLLED COPY - VERIFY REVISION BEFORE USE (Copia no controlada - verificar revision antes de usar)

SOURCE OF SUPPLY			
SUPPLIER DATA			
HARCO P/N	CARLISLE TENSOLITE PART NO.	CAGE NO.	NAME AND ADDRESS
24854-000	20444/9E004LT-2	92607	TENSOLITE COMPANY ST. AUGUSTINE, FLORIDA
24854-001	20444/9E004LT-4		
24854-002	20444/9E004LT-7		
24854-003	20444/9E004LT-11		
24854-004	20444/9E004LT-13		
24854-005	20444/9E004LT-15		
24854-006	20444/9E004LT-19		

IDENTIFICATION OF THE SUGGESTED SOURCE OF SUPPLY HEREON IS NOT TO BE CONSTRUED AS A GUARANTEE OF PRESENT OR CONTINUED AVAILABILITY AS A SOURCE OF SUPPLY FOR THE ITEM.

SOURCE CONTROL DRAWING

**Laboratories, Inc.**  
 BRANFORD, CT 06405-0010

TITLE: CABLE, 20GA, MULTI-CONDUCTOR, JUMPER, FBW, VENDOR 2

SIZE: D	CAGE CODE: 00060	DRAWING NO: 24854	REV: J
SCALE: NONE	SHEET 2 OF		5

NOTICE TO ALL PERSONS RECEIVING THIS DRAWING  
 THIS DRAWING IS ONLY CONDITIONALLY ISSUED, AND NEITHER RECEIPT NOR POSSESSION  
 THEREOF CONFER OR TRANSFERS ANY RIGHT IN, OR LICENSE TO USE THE SUBJECT MATTER  
 OF THE DRAWING OR ANY DESIGN OR TECHNICAL INFORMATION SHOWN THEREON, NOR ANY  
 RIGHT TO REPRODUCE THIS DRAWING OR ANY PART THEREOF EXCEPT FOR MANUFACTURE BY  
 VENDORS FOR HARCO LABORATORIES, INC. AND FOR MANUFACTURE UNDER THE CORPORATION'S  
 WRITTEN LICENSE. NO RIGHT TO REPRODUCE THIS DRAWING IS GRANTED UNLESS BY  
 WRITTEN AGREEMENT WITH OR WRITTEN PERMISSION FROM HARCO LABORATORIES, INC.

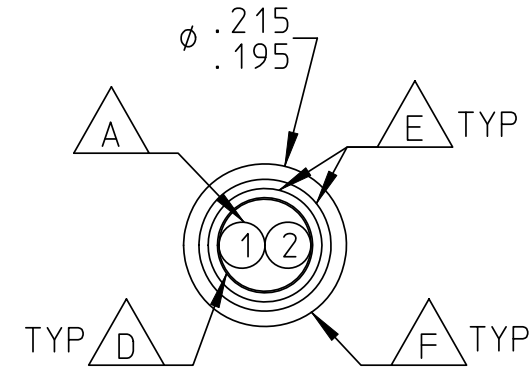

HARCO P/N 24854-000  
 BRAND-REX P/N T-14299 (2/20)

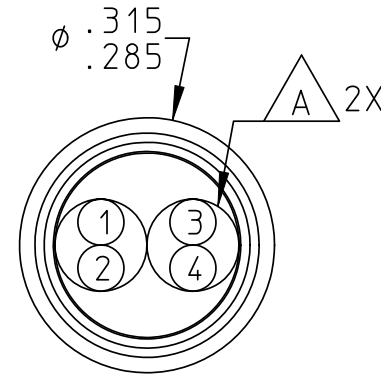

HARCO P/N 24854-001  
 BRAND-REX P/N T-14299 (4/20)

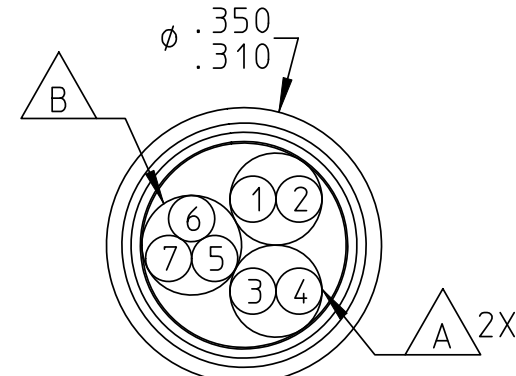

HARCO P/N 24854-002  
 BRAND-REX P/N T-14299 (7/20)

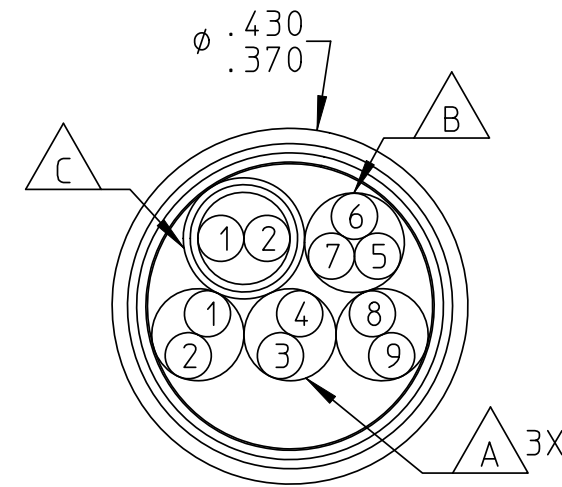

HARCO P/N 24854-003  
 BRAND-REX P/N T-14299 (11/20)

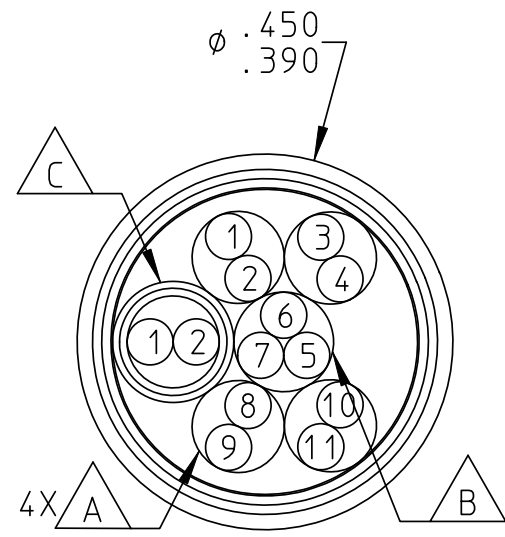

HARCO P/N 24854-004  
 BRAND-REX P/N T-14299 (13/20)

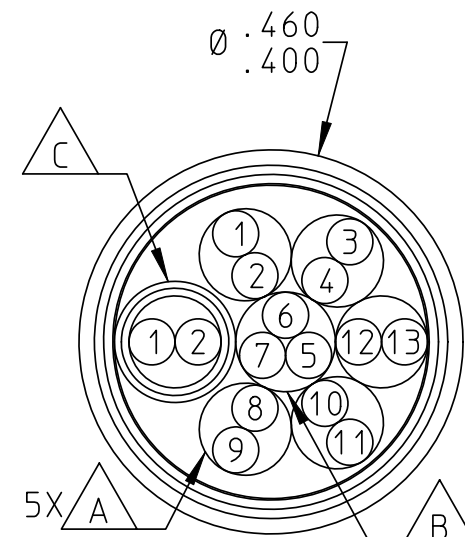

HARCO P/N 24854-005  
 BRAND-REX P/N T-14299 (15/20)

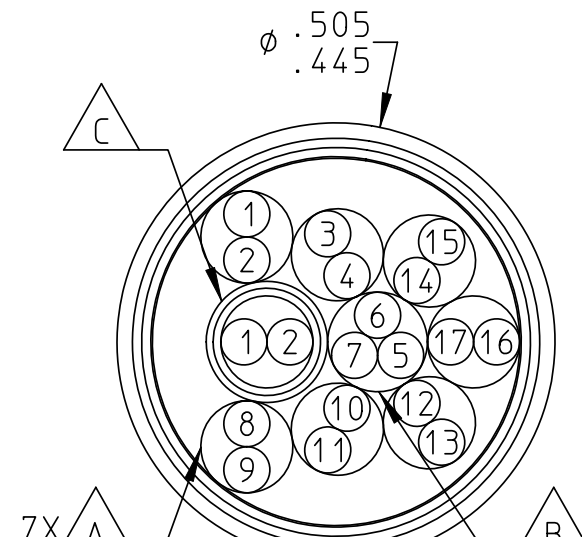

HARCO P/N 24854-006  
 BRAND-REX P/N T-14299 (19/20)

WIRE NO.	COLOR(S)
1	WHT
2	WHT/BLK
3	WHT/BRN
4	WHT/RED
5	WHT/GRN
6	WHT/ORG
7	WHT/YEL
8	WHT/BLU
9	WHT/VIO
10	WHT/GRY
11	WHT/BLK/BRN
12	WHT/BLK/RED
13	WHT/BLK/ORG
14	WHT/BLK/GRN
15	WHT/BLK/YEL
16	WHT/BLK/VIO
17	WHT/BLK/BLU

NOTES:

1. CONDUCTOR: 20AWG 63/38 NICKEL PLATED HIGH STRENGTH ALLOY 135  $\pm$  0.0415 $\pm$  .001; DCR 13 OHM/1000FT MAXIMUM. DIELECTRIC. EXTRUDED PTFE; .008 MINIMUM WALL;  $\pm$  0.059 $\pm$  .002, COLORS AS SHOWN.

A TWISTED PAIR: 2 CONDUCTOR; 1.50 INCH LH LAY.  $\phi$ .122 MAXIMUM

B TWISTED TRIPLE: 3 CONDUCTOR; 1.75 INCH LH LAY.  $\phi$ .132 MAXIMUM

C SHIELDED JACKETED TWISTED PAIR: 2 CONDUCTOR; 1.25 INCH LH LAY  
 SHIELD: 38 AWG NICKEL COPPER BRAID; 50 MICROINCHES MINIMUM NICKEL, 90% COVERAGE MINIMUM. 5 ENDS, 16 CARRIERS.  
 JACKET: 2 LAYERS CROSSWRAP UNSINTERED PTFE .003 X 3/4 45-50% LAP BOTH WRAPS,  $\phi$ .158 MAXIMUM.

D BINDER: PTFE TAPE .003 X 10% MINIMUM OVERLAP.

E OVERALL SHIELDS: THE CABLES SHALL HAVE TWO (2) OVERALL BRAIDED SHIELDS OF #36 OR #34 AWG NICKEL COATED COPPER WITH EACH HAVING A COVERAGE OF NOT LESS THAN 90%. THE BRAID ANGLE SHALL BE 40°-50°. THE COATING THICKNESS SHALL BE 40 TO 150 MICROINCHES OF NICKEL. SHIELDS SHALL BE CONTINUOUS (NO SPLICES) PER REEL. CABLE CONSTRUCTION SHALL BE IN ACCORDANCE WITH MIL-C-27500.

F OVERALL JACKETS: THE CABLES SHALL HAVE A PTFE TAPE WRAP JACKET. THE INNER TAPE SHALL BE WHITE. THE JACKET SHALL BE CONSTRUCTED AS FOLLOWS:

- TAPE ONE: .004" PTFE (WHITE) - 25-35% LAP
- TAPE TWO: .003" PTFE (YELLOW) - 25-35% LAP
- TAPE THREE: .003" PTFE (YELLOW) - 25-35% LAP
- TAPE FOUR (CABLE  $\phi$ .350" AND LARGER): .003" PTFE (YELLOW) - 25-35% LAP

JACKET MATERIAL SHALL BE 100% VIRGIN MATERIAL. VIRGIN MATERIAL SHALL BE NEW MATERIAL WHICH HAS BEEN THROUGH ONLY THE PROCESSES ESSENTIAL TO ITS MANUFACTURE OR APPLICATION AND HAS BEEN THROUGH THIS PROCESS ONE TIME ONLY. THE USE OF ANY RECLAIMED MATERIALS SHALL BE CAUSE FOR REJECTION. AND TRACEABILITY INFO.

2. CABLES SUPPLIED TO THIS DRAWING CAN NOT BE CHANGED WITHOUT PRIOR APPROVAL OF HARCO LABORATORIES, INC.

3. CABLES SUPPLIED TO THIS DRAWING SHALL BE CAPABLE OF NORMAL OPERATION AT ANY EXPOSURE TO TEMPERATURE LIMITS OF -75°C TO +90°C.

G1 4. REMOVED

G1 5. REMOVED

KEY 6. SHIELD PERFORMANCE: WHEN TESTED IN ACCORDANCE WITH MIL-C-85485, THE TRANSFER IMPEDANCE SHALL BE LESS THAN 0.01 OHMS PER METER.

UNCONTROLLED COPY - VERIFY REVISION BEFORE USE (Copia no controlada - verificar revision antes de usar)

SOURCE OF SUPPLY			
SUPPLIER DATA			
HARCO P/N	PART NO.	CAGE NO.	NAME AND ADDRESS
24854-000	T-14299 (2/20)	00012	BRAND-REX COMPANY 1000 WEST MAIN ST. WILLIMANTIC, CT 06226-1128
24854-001	T-14299 (4/20)		
24854-002	T-14299 (7/20)		
24854-003	T-14299 (11/20)		
24854-004	T-14299 (13/20)		
24854-005	T-14299 (15/20)		
24854-006	T-14299 (19/20)		

IDENTIFICATION OF THE SUGGESTED SOURCE OF SUPPLY HEREON IS NOT TO BE CONSTRUED AS A GUARANTEE OF PRESENT OR CONTINUED AVAILABILITY AS A SOURCE OF SUPPLY FOR THE ITEM.

SOURCE CONTROL DRAWING

⑬

**Laboratories, Inc.**  
 BRANFORD, CT 06405-0010

CABLE, 20GA, MULTI-CONDUCTOR,  
 JUMPER, FBW, VENDOR 3

SIZE	CAGE CODE	DRAWING NO.	REV.
D	00060	24854	J
SCALE 1:1	SHEET 3 OF 5		

NOTICE TO ALL PERSONS RECEIVING THIS DRAWING  
 THIS DRAWING IS ONLY CONDITIONALLY ISSUED, AND NEITHER RECEIPT NOR POSSESSION THEREOF CONVEYS OR TRANSFERS ANY RIGHT IN, OR LICENSE TO USE THE SUBJECT MATTER OF THE DRAWING OR ANY DESIGN OR TECHNICAL INFORMATION THEREON, NOR ANY RIGHT TO REPRODUCE THIS DRAWING OR ANY PART THEREOF EXCEPT FOR MANUFACTURE BY VENDORS FOR HARCO LABORATORIES, INC. AND FOR MANUFACTURE UNDER THE CORPORATION'S WRITTEN LICENSE. NO RIGHT TO REPRODUCE THIS DRAWING IS GRANTED UNLESS BY WRITTEN AGREEMENT WITH OR WRITTEN PERMISSION FROM HARCO LABORATORIES, INC.

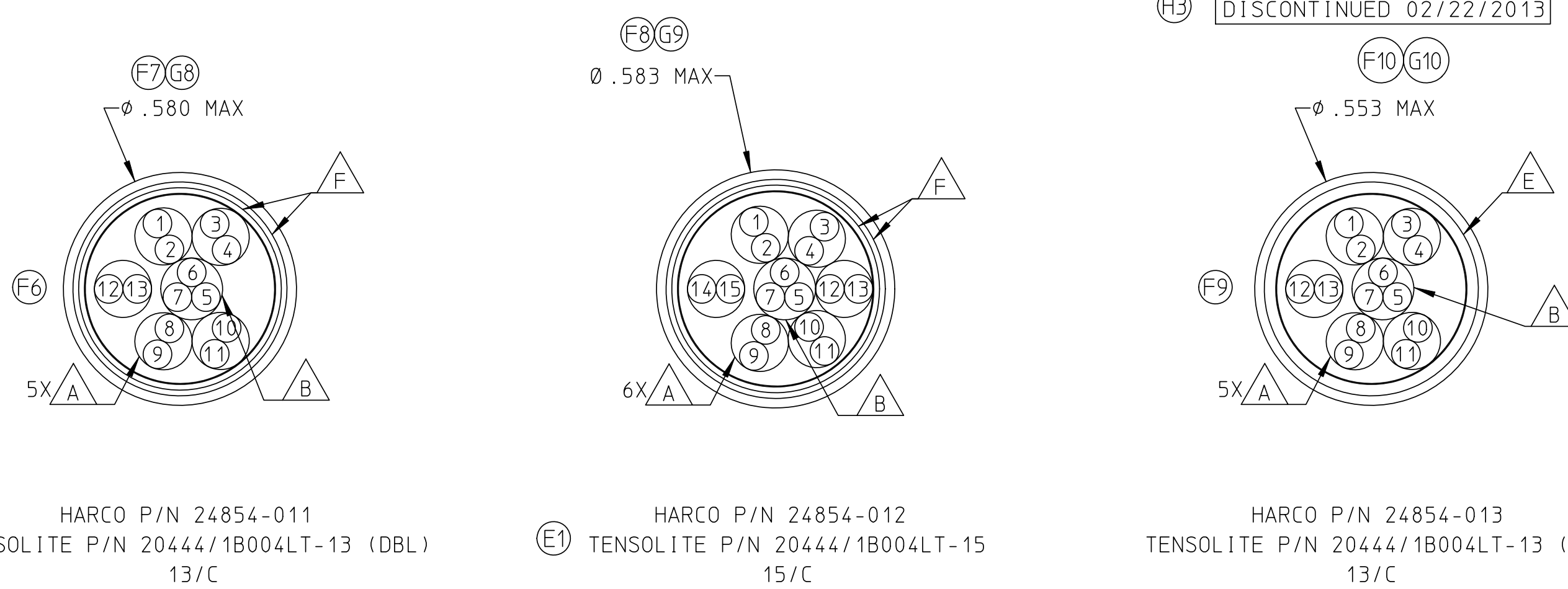
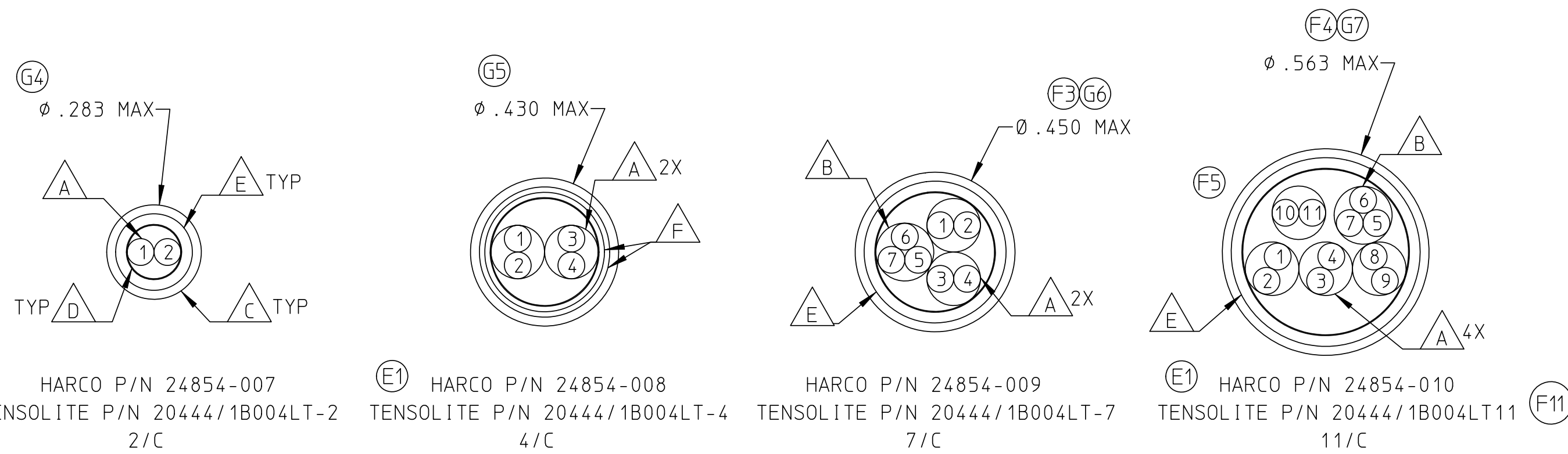

WIRE NO.	HARCO TOP LEVEL	TENSOLITE
1	WHT	WHT
2	WHT/BLK	BLK
3	WHT/BRN	BRN
4	WHT/RED	RED
5	WHT/GRN	GRN
6	WHT/ORG	ORG
7	WHT/YEL	YEL
8	WHT/BLU	BLU
9	WHT/VIO	VIO
10	WHT/GRY	GRY
11	WHT/BLK/BRN	BLK/BRN
12	WHT/BLK/RED	BLK/RED
13	WHT/BLK/ORG	BLK/ORG
14	WHT/BLK/GRN	BLK/GRN
15	WHT/BLK/YEL	BLK/YEL
16	WHT/BLK/VIO	BLK/VIO
17	WHT/BLK/BLU	BLK/BLU

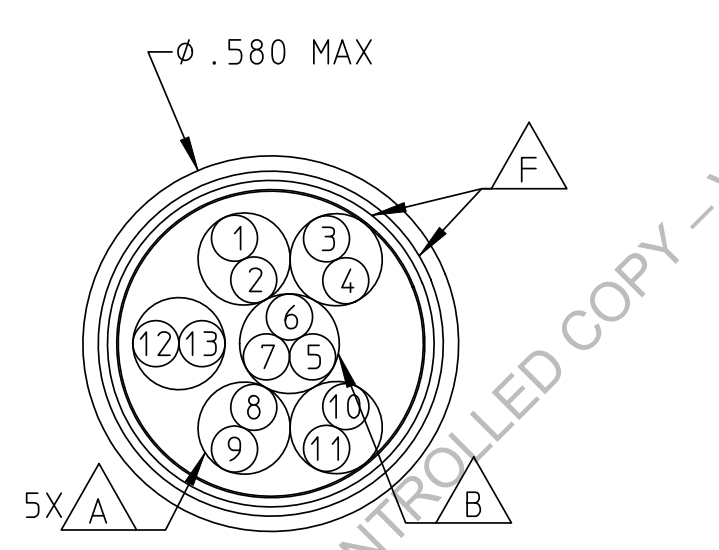

HARCO P/N	SOURCE OF SUPPLY		MAX WEIGHT	MAX OD OVER JACKET	NOTES
	CARLISLE TENSOLITE PART NO.	SUPPLIER DATA			
24854-000	20444/9E004LT-2				
24854-001	20444/9E004LT-4				
24854-002	20444/9E004LT-7				
24854-003	20444/9E004LT-11				
24854-004	20444/9E004LT-13				
24854-005	20444/9E004LT-15				
24854-006	20444/9E004LT-19				
24854-007	20444/1B004LT-2		52.5 LBS/MFT	.283*	
24854-008	20444/1B004LT-4		98.8 LBS/MFT	.430*	
24854-009	20444/1B004LT-7		123.1 LBS/MFT	.450*	
24854-010	20444/1B004LT-11		217.7 LBS/MFT	.563*	
24854-011	20444/1B004LT-13 (DBL)		226.2 LBS/MFT	.580*	
24854-012	20444/1B004LT-15		241.7 LBS/MFT	.583*	
24854-013	20444/1B004LT-13 (SGL)		192.0 LBS/MFT	.553*	DISCONTINUED
24854-014	20444/1D008LT-13 (DBL95)		240.0 LBS/MFT	.580*	

NOTES:

- CONDUCTOR: MATERIAL: NICKEL-COATED COPPER ALLOY (50 MICROINCHES MIN) SIZE:AWG 20  
 COSTRUCTION: 19 X 32 OD(NOM): .0373" DC RESISTANCE (MAX): 11.4 OHMS/1,000FT.  
 INSULATION: MATERIAL: EXTRUDED PTFE OD: .090" +/- .004  
 CONCENTRICITY: 80% MIN @ PRIMARY EXTRUSION.  
 A COMPONENT #1 (TWISTED PAIR COMPONENT):  
 CABLE TWO (2) INSULATED CONDUCTORS TOGETHER. LAY(NOM): 2 1/4" LHL  
 B COMPONENT #2 (TWISTED TRIPLE COMPONENT)  
 CABLE THREE(3) INSULATED CONDUCTORS TOGETHER. LAY(NOM): 2 1/2" LHL  
 E2 OVERALL CABLE  
 CABLE COMPONENTS ALONG WITH FIBERGLASS FILLERS AS NECESSARY FOR ROUNDNESS,  
 AND TO MINIMIZE VISIBLE CONVOLUTIONS AND HIGH SPOTS.  
 C OVERALL JACKETS:  
 1\* LAYER: .004" (NOM) PTFE TAPE; 50% MIN; 53% NOM OVERLAP  
 2\* LAYER: .003" (NOM) PTFE TAPE; 50% MIN; 53% NOM OVERLAP  
 3\* LAYER: .003" (NOM) PTFE TAPE; 50% MIN; 53% NOM OVERLAP  
 4\* LAYER: .003" (NOM) PTFE TAPE; 50% MIN; 53% NOM OVERLAP  
 JACKET MARKING TO INCLUDE - VENDOR PART NUMBER, VENDOR CAGE CODE,  
 VENDOR TRACCABILITY INFORMATION (WORKORDER, LOT#, DATE, ETC)  
 D BINDER: MATERIAL PTFE SKIVED TAPE OVERLAP: 10% (MIN)  
 E OVERALL SHIELDS: MATERIAL NICKEL-COATED COPPER (50 MICROINCHES MIN) CABLES WITH 1 SHIELD  
 SHALL HAVE A COVERAGE OF NOT LESS THAN 90%. THE BRAID ANGLE SHALL BE 40°-50°  
 H4 E3 F CABLES WITH 2 SHIELDS SHALL NOT HAVE ANY SHIELD LESS THAN 80% COVERAGE, EXCEPT AS NOTED BELOW:  
 HARCO P/N 24854-012 94% MIN COVERAGE.  
 HARCO P/N 24854-014 94% MIN COVERAGE.  
 SEE CROSSSECTION VIEW FOR OD.(NOM) AND OD.(MAX), OD REF FOR DESIGNS NOT YET BUILT.
- CABLES SUPPLIED TO THIS DRAWING CANNOT BE CHANGED WITHOUT PRIOR APPROVAL OF HARCO LABORATORIES, INC.
- CABLES SUPPLIED TO THIS DRAWING SHALL BE CAPABLE OF NORMAL OPERATION AT ANY EXPOSURE TO TEMPERATURE LIMITS OF -75°C TO +90°C.
- REMOVED
- REMOVED
- SHIELD PERFORMANCE:  

SHIELD PERFORMANCE TABLE			
HARCO P/N	CARLISLE TENSOLITE PART NO.	MAX TRANSFER INDUCTANCE	MAX TRANSFER SHIELD RESISTANCE
24854-007	20444/1B004LT-2	.500 nH/M	.0150 OHMS/METER
24854-008	20444/1B004LT-4	.500 nH/M	.0084 OHMS/METER
24854-009	20444/1B004LT-7	.500 nH/M	.0130 OHMS/METER
24854-010	20444/1B004LT-11	.500 nH/M	.0089 OHMS/METER
24854-011	20444/1B004LT-13 (DBL)	.500 nH/M	.0052 OHMS/METER
24854-012	20444/1B004LT-15	.045 nH/M	.0038 OHMS/METER
24854-014	20444/1D008LT-13 (DBL95)	.035 nH/M	.0037 OHMS/METER

 WHEN TESTED IN ACCORDANCE WITH AS-85485.
- WEIGHT - SEE TABLE BELOW.
- WIRE COLOR CODING: WHITE BACKGROUND WITH COLOR STRIPE IS OPTIONAL. SOLID COLORS ARE ACCEPTABLE. i.e. WHT/ORG MAY BE ORANGE, WHT/GRN MAY BE GREEN

SOURCE CONTROL DRAWING

**Laboratories, Inc.**  
 BRANFORD, CT 06405-0010  
 CABLE, 20GA, MULTI-CONDUCTOR,  
 JUMPER, FBW, VENDOR 2  
 SIZE: D CAGE CODE: 00060 DRAWING NO: 24854 REV: J  
 SCALE: 1:1 SHEET 4 OF 5

IDENTIFICATION OF THE SUGGESTED SOURCE OF SUPPLY HEREON IS NOT TO BE CONSTRUED AS A GUARANTEE OF PRESENT OR CONTINUED AVAILABILITY AS A SOURCE OF SUPPLY FOR THE ITEM.

NOTICE TO ALL PERSONS RECEIVING THIS DRAWING  
 THIS DRAWING IS ONLY CONDITIONALLY ISSUED, AND NEITHER RECEIPT NOR POSSESSION THEREOF CONFER OR TRANSFERS ANY RIGHT IN, OR LICENSE TO USE THE SUBJECT MATTER OF THE DRAWING OR ANY DESIGN OR TECHNICAL INFORMATION DERIVED THEREFROM, NOR ANY RIGHT TO REPRODUCE THIS DRAWING OR ANY PART THEREOF EXCEPT FOR MANUFACTURE BY VENDORS FOR HARCO LABORATORIES, INC. AND FOR MANUFACTURE UNDER THE CORPORATION'S WRITTEN LICENSE. NO RIGHT TO REPRODUCE THIS DRAWING IS GRANTED UNLESS BY WRITTEN AGREEMENT WITH OR WRITTEN PERMISSION FROM HARCO LABORATORIES, INC.

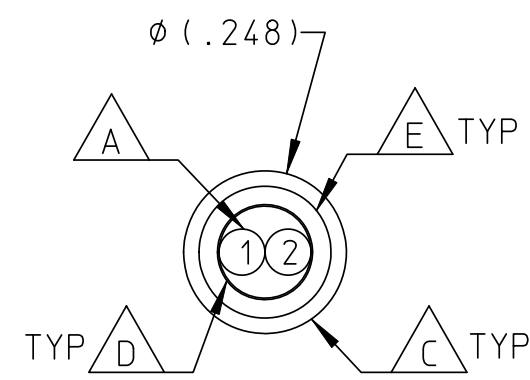

HARCO P/N 24854-007  
 THERMAX P/N 1289-02

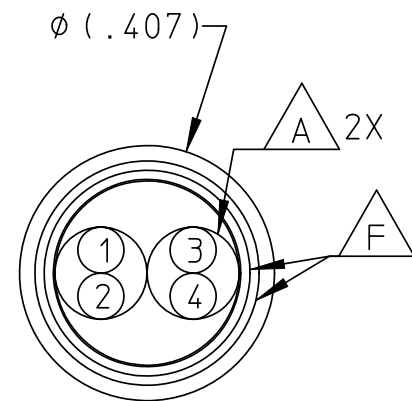

HARCO P/N 24854-008  
 THERMAX P/N 1289-04

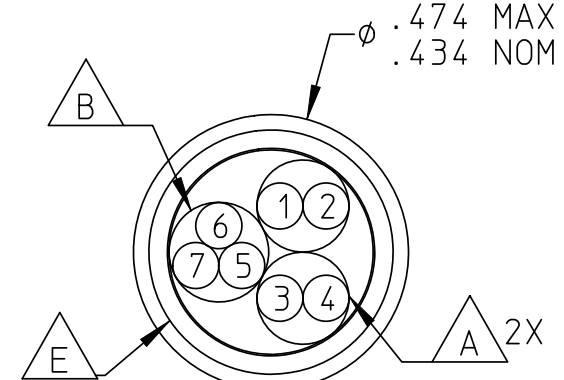

HARCO P/N 24854-009  
 THERMAX P/N 1289-07

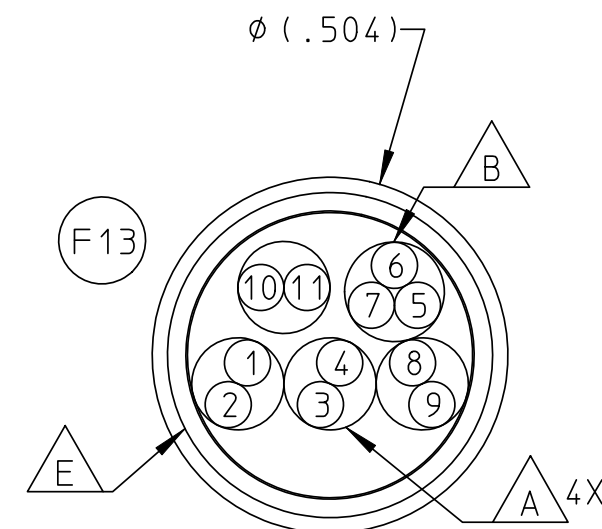

HARCO P/N 24854-010  
 THERMAX P/N 1289-11

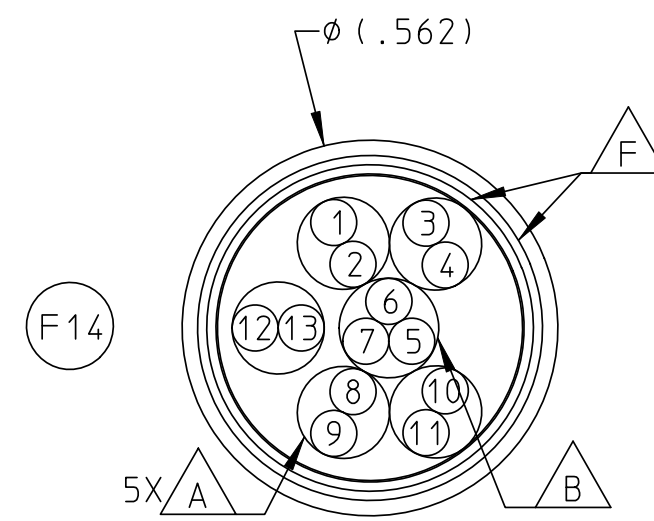

HARCO P/N 24854-011  
 THERMAX P/N 1289-13D

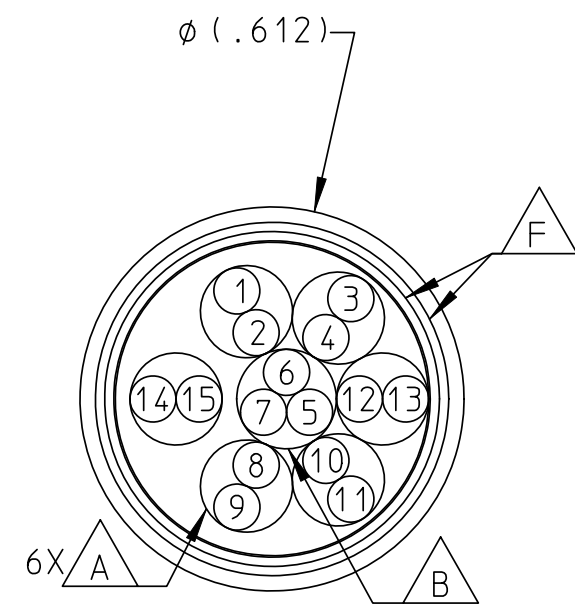

HARCO P/N 24854-012  
 THERMAX P/N 1289-15

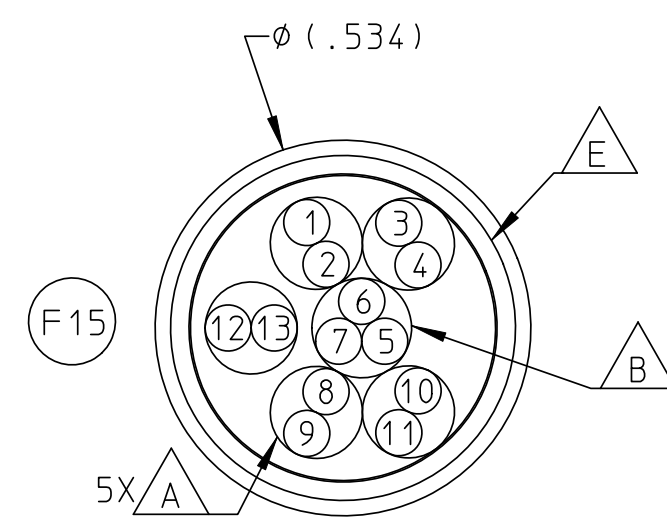

HARCO P/N 24854-013  
 THERMAX P/N 1289-13

WIRE NO.	HARCO TOP LEVEL	THERMAX
1	WHT	WHT
2	WHT/BLK	BLK
3	WHT/BRN	BRN
4	WHT/RED	RED
5	WHT/GRN	GRN
6	WHT/ORG	ORG
7	WHT/YEL	YEL
8	WHT/BLU	BLU
9	WHT/VIO	VIO
10	WHT/GRY	GRY
11	WHT/BLK/BRN	BLK/BRN
12	WHT/BLK/RED	BLK/RED
13	WHT/BLK/ORG	BLK/ORG
14	WHT/BLK/GRN	BLK/GRN
15	WHT/BLK/YEL	BLK/YEL
16	WHT/BLK/VIO	BLK/VIO
17	WHT/BLK/BLU	BLK/BLU

NOTES:

1. CONDUCTOR: MATERIAL: NICKEL-COATED COPPER ALLOY (50 MICROINCHES MIN) SIZE:AWG 20  
 COSTRUCTION: 19 X 32 OD(NOM): .0373" DC RESISTANCE (MAX): 11.4 OHMS/1,000FT.

INSULATION: MATERIAL: EXTRUDED PTFE OD: .090" +/- .004  
 CONCENTRICITY: 80% MIN @ PRIMARY EXTRUSION.

A COMPONENT #1 (TWISTED PAIR COMPONENT):  
 CABLE TWO (2) INSULATED CONDUCTORS TOGETHER. LAY(NOM): 2 1/4" LHL

B COMPONENT #2 (TWISTED TRIPLE COMPONENT)  
 CABLE THREE(3) INSULATED CONDUCTORS TOGETHER. LAY(NOM): 2 1/2" LHL

OVERALL CABLE  
 CABLE COMPONENTS ALONG WITH FIBERGLASS FILLERS AS NECESSARY FOR ROUNDNESS,  
 AND TO MINIMIZE VISIBLE CONVOLUTIONS AND HIGH SPOTS.

C OVERALL JACKETS:

- 1\* LAYER: .004" (NOM) PTFE TAPE; 50% MIN; 53% NOM OVERLAP
- 2\* LAYER: .003" (NOM) PTFE TAPE; 50% MIN; 53% NOM OVERLAP
- 3\* LAYER: .003" (NOM) PTFE TAPE; 50% MIN; 53% NOM OVERLAP
- 4\* LAYER: .003" (NOM) PTFE TAPE; 50% MIN; 53% NOM OVERLAP

JACKET MARKING TO INCLUDE - VENDOR PART NUMBER, VENDOR CAGE CODE,  
 VENDOR TRACABILITY INFORMATION (WORKORDER, LOT#, DATE, ETC)

D BINDER: MATERIAL PTFE SKIVED TAPE OVERLAP: 10% (MIN)

E OVERALL SHIELDS: MATERIAL NICKEL-COATED COPPER (50 MICROINCHES MIN) CABLES WITH 1 SHIELD  
 SHALL HAVE A COVERAGE OF NOT LESS THAN 90%. THE BRAID ANGLE SHALL BE 40°-50°

F CABLES WITH 2 SHIELDS SHALL NOT HAVE ANY SHIELD LESS THAN 80% COVERAGE.

SEE CROSSSECTION VIEW FOR OD.(NOM) AND OD.(MAX), OD REF FOR DESIGNS NOT YET BUILT.

2. CABLES SUPPLIED TO THIS DRAWING CAN NOT BE CHANGED WITHOUT PRIOR APPROVAL OF HARCO LABORATORIES, INC.

3. CABLES SUPPLIED TO THIS DRAWING SHALL BE CAPABLE OF NORMAL OPERATION AT ANY EXPOSURE TO TEMPERATURE LIMITS OF -75°C TO +90°C.

G1 4. REMOVED

G1 5. REMOVED

G2 KEY 6. SHIELD PERFORMANCE: WHEN TESTED IN ACCORDANCE WITH AS-85485, THE TRANSFER IMPEDANCE SHALL BE LESS THAN 0.015 OHMS PER METER FROM DC TO 10 MHZ & LESS THAN .100 OHMS/M TO 100 MHZ FOR 24854-007 THROUGH 24854-013 TRANSFER RESISTANCE SHALL BE LESS THAN .015 OHMS PER METER. TRANSFER INDUCTANCE SHALL BE LESS THAN 3.0 nH PER METER FOR ALL MEASURED FREQUENCIES THROUGH 100 MHZ. TRANSFER IMPEDANCE PER METER SHALL BE LESS THAN (2 \* PI() \* FREQUENCY \* 1 nH)/METER FOR ALL MEASURED FREQUENCIES FROM 10 MHZ THROUGH 100 MHZ.

7. WEIGHT - SEE TABLE BELOW.

F12 8. WIRE COLOR CODING: WHITE BACKGROUND WITH COLOR STRIPE IS OPTIONAL. SOLID COLORS ARE ACCEPTABLE. i.e. WHT/ORG MAY BE ORANGE. WHT/GRN MAY BE GREEN.

SOURCE OF SUPPLY			
SUPPLIER DATA			
HARCO P/N	THERMAX P/N	NOMINAL WEIGHT	NOMINAL OD OVER JACKET
24854-007	1289-02	48 LBS/MFT	.248"
24854-008	1289-04	85 LBS/MFT	.407"
24854-009	1289-07	120 LBS/MFT	.434"
24854-010	1289-11	166 LBS/MFT	.504"
24854-011	1289-13D	219 LBS/MFT	.562"
24854-012	1289-15	247 LBS/MFT	.612"
24854-013	1289-13	190 LBS/MFT	.534"

IDENTIFICATION OF THE SUGGESTED SOURCE OF SUPPLY HEREON IS NOT TO BE CONSTRUED AS A  
 GUARANTEE OF PRESENT OR CONTINUED AVAILABILITY AS A SOURCE OF SUPPLY FOR THE ITEM.

THIS DESIGN (.090" PRIMARY) BY THERMAX IS NOT YET APPROVED BY BOEING. HAS NOT PASSED FLEX & ROTATE QUALIFICATION.

SOURCE CONTROL DRAWING

**Laboratories, Inc.**  
 BRANFORD, CT 06405-0010

TITLE: CABLE, 20GA, MULTI-CONDUCTOR, JUMPER, FBW, VENDOR 4

SIZE: D	CAGE CODE: 00060	DRAWING NO: 24854	REV: J
SCALE: 1:1		SHEET 5 OF 5	