

NOTICE TO ALL PERSONS RECEIVING THIS DRAWING  
 THIS DRAWING IS ONLY CONDITIONALLY ISSUED, AND NEITHER RECEIPT NOR POSSESSION  
 THEREOF CONSTITUTES AN ENDORSEMENT OR WARRANTY BY HARC0 LABORATORIES, INC.  
 FOR THE USE OF THE DRAWING IN ANY MANNER OR FOR THE USE OF THE DRAWING IN ANY  
 MANNER OTHER THAN THAT SPECIFICALLY AUTHORIZED BY HARC0 LABORATORIES, INC.  
 HARC0 LABORATORIES, INC. HAS THE RIGHT TO REVOKE THIS DRAWING AT ANY TIME  
 WITHOUT NOTICE AND WITHOUT LIABILITY TO ANY PERSON RECEIVING THIS DRAWING.  
 HARC0 LABORATORIES, INC. HAS THE RIGHT TO REPRODUCE THIS DRAWING IN ANY  
 MANNER WITHOUT PERMISSION FROM HARC0 LABORATORIES, INC.

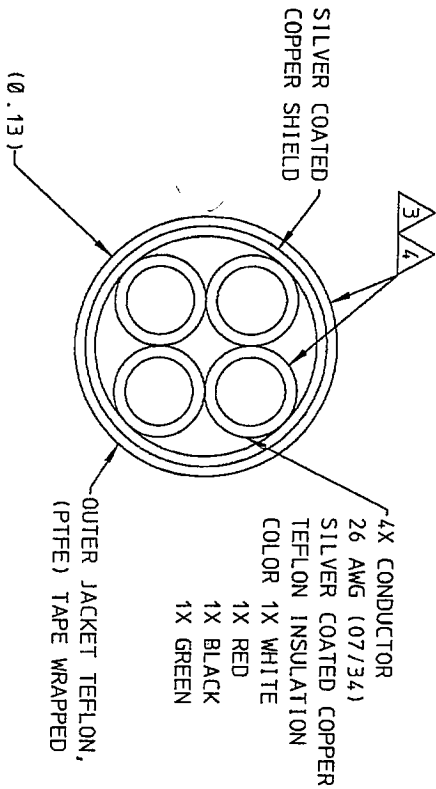

UNCONTROLLED COPY  
 REVISION BEFORE USE

| ECP | EGR | REL DATE | REV. LET. | REVISION            | REV. BY | CHK BY | APPROVED BY |
|-----|-----|----------|-----------|---------------------|---------|--------|-------------|
|     |     | 03-10-02 | -         | SEE DCR# 27257-000- | JAN     | JAN    | ENG H.E. DA |

NOTES:

- CABLE TO MEET THE REQUIREMENTS OF M16878/21BDB9, TYPE E
  - CONDUCTOR CONSTRUCTION.
  - CABLE JACKET INSULATION.
  - SHIELD APPLICATION.
  - ELECTRICAL REQUIREMENTS.
- MARKER TAPE IDENTIFICATION IS NOT REQUIRED IN THIS CABLE.
- INNER JACKETS TO BE ETCHED.
- INSULATION THICKNESS TO BE .010 TYP.

|  |  |                          |  |          |  |                           |  |
|--|--|--------------------------|--|----------|--|---------------------------|--|
| UNLESS OTHERWISE SPECIFIED, DIMENSIONS ARE IN INCHES |  | APPROVALS                |  | DATE     |  | TITLE                     |  |
| TOLERANCES ARE: .010                                 |  | DRAWN JRN                |  | 98-06-02 |  | CABLE, ELECTRICAL,        |  |
| FIT TOLERANCES ARE: .010                             |  | CHECKED -                |  | 98-06-02 |  | 4 COND, 26 GA (M16878/21) |  |
| MATERIAL SPEC: DO NOT SCALE DRAWING                  |  | ENGR DE                  |  | 98-06-98 |  | DRAWING NO. 27257-000     |  |
| FINISH SPEC:   |  | M.E. HW                  |  | 98-08-21 |  | REV. -                    |  |
| NEXT ASSEMBLY:                                       |  | PREPARED UNDER CONTRACT  |  | 98-08-22 |  | SHEET 1 OF 1              |  |
| APPLICATION:   |  | FURNISHED UNDER CONTRACT |  | 98-08-22 |  | PART NUMBER 27257-000     |  |

**Laboratories, Inc.**  
 BRANFORD, CT 06405-0010