

NOTICE TO ALL PERSONS RECEIVING THIS DRAWING

THIS DRAWING IS ONLY CONDITIONALLY ISSUED, AND NEITHER RECEIPT NOR POSSESSION THEREOF CONFERS OR TRANSFERS ANY RIGHT IN, OR LICENSE TO USE THE SUBJECT MATTER OF THE DRAWING OR ANY DESIGN OR TECHNICAL INFORMATION SHOWN THEREON NOR ANY RIGHT TO REPRODUCE THIS DRAWING OR ANY PART THEREOF EXCEPT FOR MANUFACTURE BY VENDORS FOR HARCO LABORATORIES INC AND FOR MANUFACTURE UNDER THE CORPORATION'S WRITTEN LICENSE NO RIGHT TO REPRODUCE THIS DRAWING IS GRANTED UNLESS BY WRITTEN AGREEMENT WITH OR WRITTEN PERMISSION FROM HARCO LABORATORIES INC

| ECP | ECR | REL DATE | REV. LET. | REVISION                         | REV. BY | CHK BY | APPROVED BY |      |     |
|-----|-----|----------|-----------|----------------------------------|---------|--------|-------------|------|-----|
|     |     |          |           |                                  |         |        | ENG         | M.E. | QA  |
|     |     | 4-21-08  | -         | DCRA 28964-000-, INITIAL RELEASE | RFP     | RFP    | RCG         | MCJ  | JSP |

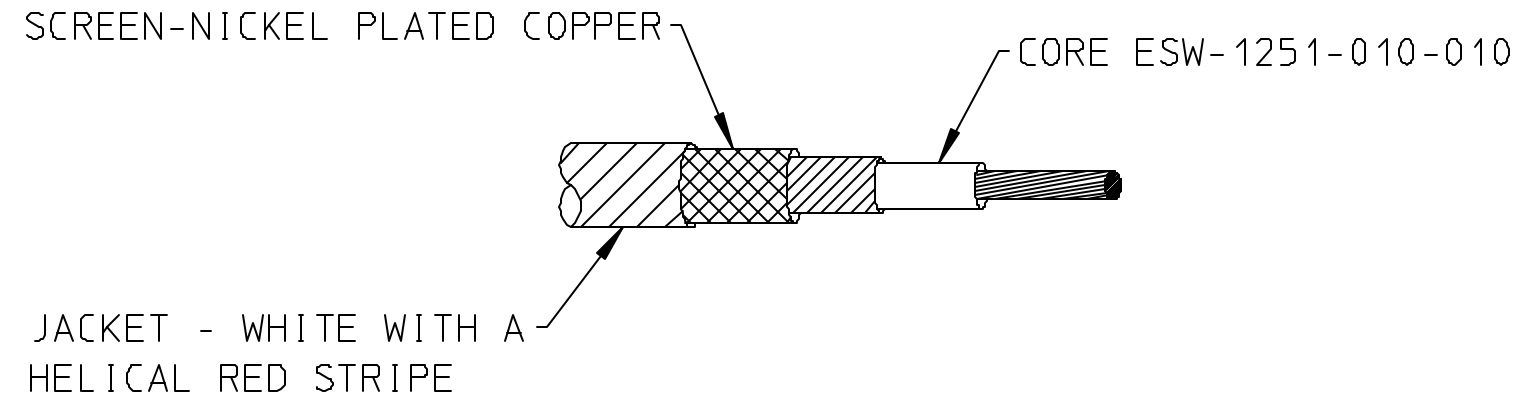

DESCRIPTION:

CONDUCTOR - 010 EUROPEAN ASSOCIATION OF AEROSPACE INDUSTRIES NICKEL PLATED COPPER ALLOY

INSULATION - FIREPROOF INSULATION

SECOND INSULATION - SINTERED PTFE TAPE (.070 OD)

BRAID - NPC

JACKET - WHITE WITH RED HELICAL STRIPE SINTERED PTFE TAPE WRAP (.120 OD)

WIRE MUST BE PURCHASED FROM ROLLS ROYCE APPROVED SOURCE BELDEN, UK DISTRIBUTOR DAX INTERNATIONAL

|           |                  |
|-----------|------------------|
| HARCO P/N | ROLLS ROYCE P/N  |
| 28964-000 | ESW-1253-012-010 |

SPECIFICATION CONTROL DRAWING

UNLESS OTHERWISE SPECIFIED, DIMENSIONS ARE IN INCHES  
 TOLERANCES ARE:  
 DECIMALS ±.010  
 FRACTIONS ±1/32  
 ANGLES ±2°  
 ALL DIAMETERS  $\text{Ⓢ} \text{ } \varnothing .010$   
 BREAK EDGES .005-.020  
 FILLETS TO BE .005-.020  
 SURFACE FINISH 125 ✓

| APPROVALS |     | DATE    |
|-----------|-----|---------|
| DRAWN     | RFP | 4-16-08 |
| CHECKED   | RFP | 4-16-08 |
| ENGR      | -   |         |
| DE        | RCG | 4-18-08 |
| M.E.      | MCJ | 4-18-08 |
| QA        | JSP | 4-18-08 |

**HARCO Laboratories, Inc.**  
 BRANFORD, CT 06405-0010

TITLE: WIRE, 1 COND, ELECT, ESW-1253-012-010

|               |             |                          |               |                        |                       |              |
|---------------|-------------|--------------------------|---------------|------------------------|-----------------------|--------------|
| MATERIAL SPEC | FINISH SPEC | PREPARED UNDER CONTRACT  | SIZE <b>B</b> | CAGE CODE <b>00060</b> | DRAWING NO. 28964-000 | REV. -       |
|               |             | FURNISHED UNDER CONTRACT | SCALE NONE    |                        |                       | SHEET 1 OF 1 |