

1. CONDUCTOR

Material: Tin Plated Copper
 Construction: See Table 1
 Diameter: See Table 1

2. INSULATION

Material
 Layer 1: Irradiation Crosslinked Polyolefin
 Layer 2: Irradiation Crosslinked PVDF
 Wall thickness
 Layer 1: See Table 1
 Layer 2: 0.003" nom
 Diameter: See Table 1
 Color: Customer Specified
 Marking: JUDD WIRE FLEXRAD 44 1/C #XX
 AWG ZZ/ZZ 150°C 600V (YYYY)

XX – Denotes AWG Size
 ZZ/ZZ – Denotes Conductor Standing
 YYYY – Denotes Year of Manufacture

3. PHYSICAL CHARACTERISTICS

Temperature rating: 150°C
 Voltage rating: 600V
 Weight: See Table 1

4. PERFORMANCE PROPERTIES – AS81044/12

Mechanical
 Elongation 150%, min
 Tensile Strength 2500 psi, min
 Concentricity 70%, min
 Wicking 2.25", max
 Bend Test
 See Table 2 for Mandrel Requirements
 Print Durability 125 Cycles, 500g
 Mandrel Wrap Test
 See Table 2 for Mandrel Requirements
 No Cracks, Pass Wet Dielectric Test

Electrical
 Impulse Dielectric Test 6.0/8.0 kV_{ac}
 Wet Dielectric Test (5 hrs @ 25°C)
 5% NaCl Solution, 2500 V, 5 min
 Insulation Resistance 5000 MΩ/kft, min
 Direct Current Resistance @ 20°C See Table 1
 Surface Resistance 500 MΩ·in, Initial and Final Readings, min
 Spark Test 1500 V

Thermal
 Shrinkage (6 hrs @ 300°C) 0.125 in, max
 Life Cycle (168 hrs @ 200°C)
 No Cracks, No Conductor Pitting

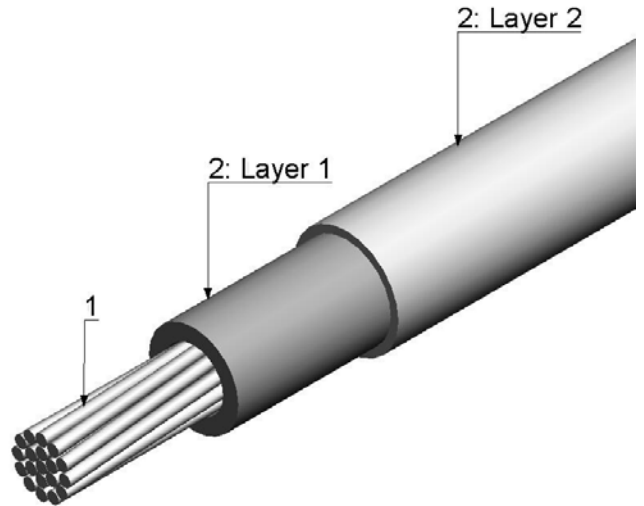

PERFORMANCE PROPERTIES (Con't)

Accelerated Aging I (6 hrs @ 300°C)
 No Cracks, No Conductor Pitting
 Pass Wet Dielectric Test
 Accelerated Aging II (6 hrs @ 225°C)
 Print shall Remain Legible
 Cold Bend (4 hrs @ -65°C)
 See Table 2 for Mandrel Requirements
 No Cracks, Pass Wet Dielectric Test
 Thermal Shock Resistance
 High Temperature 30 min @ 150°C
 Low Temperature 30 min @ -55°C
 Number of Cycles 4
 Change in Measurement 0.060", max
 Humidity Resistance 5000 MΩ/kft, min
 Blocking (24 hrs @ 225°C)
 Adjacent Wire Shall not Stick
 Flammability 60° Angle
 Maximum Burn Time 30 sec
 Maximum Char Length 3.0"
 Tissue Paper No Flame
 Smoke Test (15 min @ 200°C)
 No Indication of Visible Smoke

Chemical
 Immersion Tests (20 hrs @ 50°C)
 No Cracks, Pass Wet Dielectric
 OD Increase, Max
 Lubricating Oil 5%
 Hydraulic Fluid 5%
 Isopropyl Alcohol 5%
 Turbine Fuel 5%

5. REFERENCE SPECIFICATION

SAE AS81044
 SAE AS81044/12



JUDD WIRE INC.
 124 Turnpike Road
 Turners Falls, MA 01376
 (413) 863-4357

Date	Rev	By	Appr'd	ECN
06/20/13	--	EM	GT	---
Customer Approval:				

Description: HOOKUP, TPC, DUAL WALL FLEXRAD 44 150°C, 600V	
Specification Number: JW1501-13	Page: 1 of 2

Table 1 - Construction Details

Size (AWG)	Conductor				Insulation					Ampacity
	Stranding	Diameter		DCR (Ω/kft), max	Layer 1 Wall Thickness (in), nom	Diameter			Weight (lbs/kft)	
		#/AWG	Min			Max	Min	Nom	Max	Nom
24	19/36	0.023	0.026	26.2	0.006	0.038	0.04	0.042	2	6
22	19/34	0.025	0.033	10.2	0.006	0.045	0.047	0.049	2.5	10
20	19/32	0.037	0.041	9.88	0.006	0.053	0.055	0.057	4.4	11
18	19/30	0.046	0.051	6.23	0.006	0.063	0.065	0.067	6.8	15
16	19/29	0.052	0.058	4.81	0.006	0.069	0.072	0.075	8.5	18
16	37/32*	0.053	0.059	4.49	0.006	0.071	0.074	0.077	8.5	18
14	19/27	0.065	0.073	3.06	0.006	0.085	0.089	0.093	13.4	26
12	37/28	0.084	0.09	2.02	0.007	0.104	0.108	0.112	20.7	35
12	65/30*	0.086	0.095	1.81	0.007	0.108	0.112	0.116	21.9	35

* - Stranding not listed in 81044 specification

** - Calculations Based on: Single Conductor Installed in free 40°C air, 110°C Temperature Rating

Table 2: Test Requirements

Size (AWG)	Bend Test Requirements				
	Mandrel Diameter (in)			Test Load (lbs)	
	Life Cycle and Acc. Aging Test	Cold Bend Testing	Wrap Test	Life Cycle and Acc. Aging Test	Cold Bend Test
24	0.50	0.50	0.250	0.38	0.50
22	0.75	0.75	0.250	0.36	1.00
20	0.75	1.00	0.250	0.36	1.00
18	1.00	1.50	0.375	0.50	1.00
16	1.00	1.50	0.375	0.50	1.00
14	1.50	2.00	0.500	1.00	3.00
12	2.00	2.00	0.500	1.00	3.00



JUDD WIRE INC.
 124 Turnpike Road
 Turners Falls, MA 01376
 (413) 863-4357

Description:

**HOOKUP, TPC, DUAL WALL
 FLEXRAD 44 150°C, 600V**

Specification Number:

JW1501-13

Rev:

--

Page:

2 of 2