

1. CONDUCTOR

Material: Tin Plated Copper
 Construction: See Table 1
 Diameter: See Table 1

2. INSULATION

Material
 Layer 1: Irradiation Crosslinked Polyolefin
 Layer 2: Irradiation Crosslinked PVDF
 Diameter: See Table 1
 Color: Customer Specified
 Marking: JUDD WIRE FLEXRAD 44 1/C #XX
 AWG ZZ/ZZ 150°C 2000V (YYYY)

XX – Denotes AWG Size
 ZZ/ZZ – Denotes Conductor Standing
 YYYY – Denotes Year of Manufacture

3. PHYSICAL CHARACTERISTICS

Temperature rating: 150°C
 Voltage rating: 2000V
 Weight: See Table 1

4. PERFORMANCE PROPERTIES

Mechanical
 Elongation 150%, min
 Tensile Strength See Table 2
 Concentricity 70%, min
 Wicking 2.25", max
 Bend Test Pass
 Print Durability 125 Cycles, 500g
 Mandrel Wrap Test
 No Cracks, Pass Wet Dielectric Test

Electrical
 Dielectric Test 5.7 kV_{ac}
 Wet Dielectric Test
 5 hrs @ 25°C, 5% NaCl Solution, 4.5 kV, 5 min
 168 Hrs @ 180°C, 5 kV, 5min
 168 Hrs @ 180°C + 1 Hr @ 150°C 5 kV, 5min
 Insulation Resistance 5000 MΩ/kft, min
 Direct Current Resistance @ 20°C See Table 1
 Surface Resistance
 500 MΩ·in, Initial and Final Readings, min
 Spark Test 10000 V

Thermal
 Shrinkage (6 hrs @ 300°C) See Table 2
 Life Cycle (168 hrs @ 200°C)
 No Cracks, No Conductor Pitting
 Pass Wet Dielectric Test

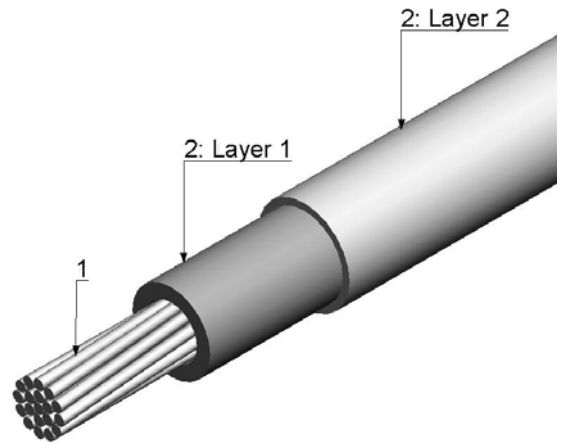

PERFORMANCE PROPERTIES (Con't)

Accelerated Aging I (6 hrs @ 300°C)
 No Cracks, No Conductor Pitting
 Pass Wet Dielectric Test
 Accelerated Aging II (6 hrs @ 225°C)
 Print shall Remain Legible
 Cold Bend (4 hrs @ -65°C)
 See Table 2 for Mandrel Requirements
 No Cracks, Pass Wet Dielectric Test
 Thermal Shock Resistance
 High Temperature 30 min @ 150°C
 Low Temperature 30 min @ -55°C
 Number of Cycles 4
 Change in Measurement 0.060", max
 Humidity Resistance 5000 MΩ/kft, min
 Blocking (24 hrs @ 225°C)
 Adjacent Wire Shall not Stick
 Flammability 60° Angle
 Maximum Burn Time 30 sec
 Maximum Char Length 3.0"
 Tissue Paper No Flame
 Smoke Test (15 min @ 200°C)
 No Indication of Visible Smoke

Chemical

Immersion Tests (20 hrs @ 50°C)
 No Cracks, Pass Wet Dielectric
 OD Increase, Max
 Lubricating Oil 5%
 Hydraulic Fluid 5%
 Isopropyl Alcohol 5%
 Turbine Fuel 5%

5. REFERENCE SPECIFICATION

SAE AS81044
 ICEA S-95-658



JUDD WIRE INC.
 124 Turnpike Road
 Turners Falls, MA 01376
 (413) 863-4357

Date	Rev	By	Appr'd	ECN
06/20/13	B	EM	GT	13-1393
08/06/13	C	EM	GT	13-1413
09/05/13	D	EM	GT	13-1422
Customer Approval:				

Description:
**HOOKUP, TPC, DUAL WALL
 FLEXRAD 44 150°C, 2000V**

Specification Number: **JW1445-13** Page: 1 of 2

Table 1 - Construction

Size (AWG)	Conductor				Insulation					Ampacity
	Stranding	Diameter		DCR (Ω/kft), max (20°C)	Layer 1 Wall Thickness (in), nom	Diameter			Weight (lbs/kft)	
	#/AWG	Min	Max			Min	Nom	Max	Nom	A, max*
20	19/32	0.037	0.041	9.88	0.015	0.076	0.078	0.080	7	13
18	19/30	0.046	0.048	6.23	0.016	0.085	0.088	0.091	10	17
16	19/29	0.056	0.058	4.4	0.016	0.095	0.098	0.101	13	21
14	19/27	0.065	0.075	3.05	0.018	0.108	0.115	0.122	18	28
12	19/25	0.079	0.091	1.92	0.018	0.124	0.131	0.138	25	38
12	37/28	0.084	0.09	2.02	0.018	0.126	0.133	0.140	25	38
12	65/30	0.086	0.095	1.81	0.018	0.129	0.136	0.143	25	38
10	37/26	0.106	0.116	1.26	0.018	0.152	0.160	0.168	40	52
8	37/24	0.132	0.136	0.793	0.021	0.178	0.188	0.198	65	81
8	133/29	0.162	0.171	0.701	0.021	0.210	0.220	0.230	70	81

* - Calculations Based on: Single Conductor Installed in free 40°C air, 110°C Temperature Rating



JUDD WIRE INC.
 124 Turnpike Road
 Turners Falls, MA 01376
 (413) 863-4357

Description:

**HOOKUP, TPC, DUAL WALL
 FLEXRAD 44 150°C, 2000V**

Specification Number:

JW1445-13

Rev:
D

Page:
 2 of 2