

# INSTRUCTION SHEET

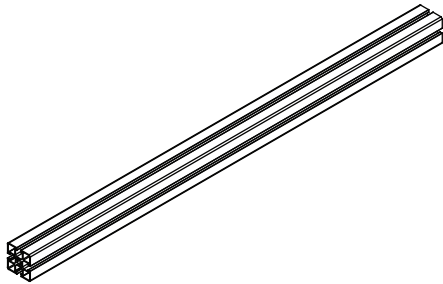
## LD-WK

### LD-12 TO LCD DESK WEDGE JOINER KIT

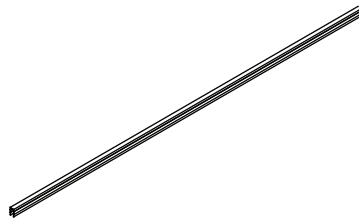
#### PRODUCT FEATURE

The LD-12 to LCD Desk Wedge Joiner Kit (LD-WK), enables the attachment of an LD Series LCD Desk Wedge to an LD-12 Cabinet.

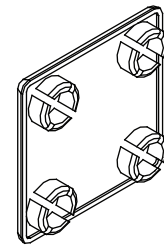
#### PARTS SUPPLIED



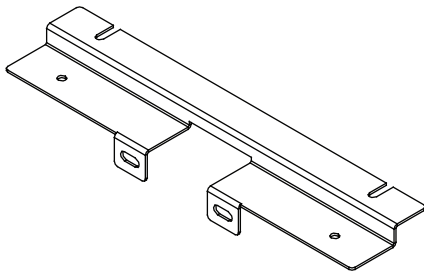
(1) 32" Extrusion



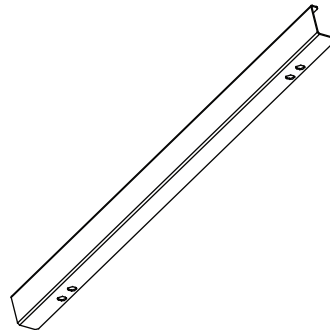
(1) Cover Molding



(2) Square Cap



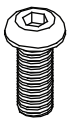
(1) LCD Desk Top Support



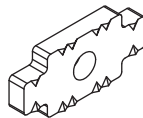
(1) LD-WK Bracket



(2) 1/4-20 Flange Nut



(6) 1/4-20X5/8" Allen Screw



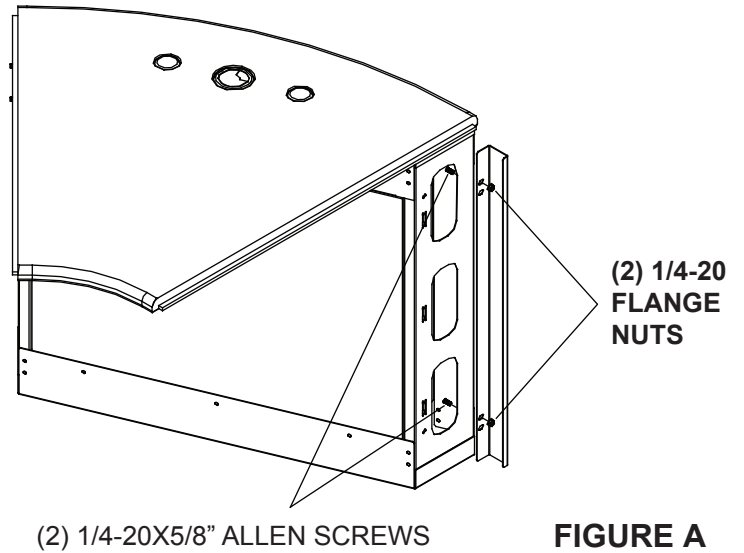
(2) 1/4-20 Sliding Nut



(2) #10 x 5/8" Panhead Screw

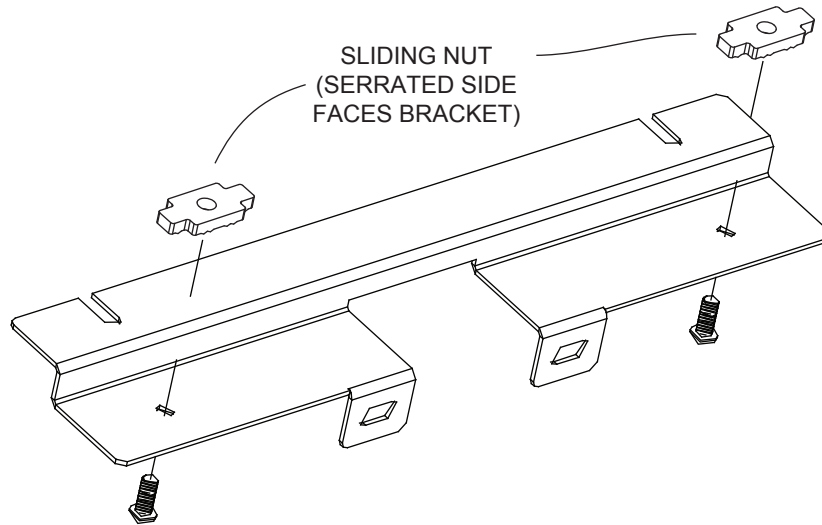
## **INSTALLATION**

- 1) Install LD-WK bracket onto LD Series Wedge as shown. **(FIGURE A)**

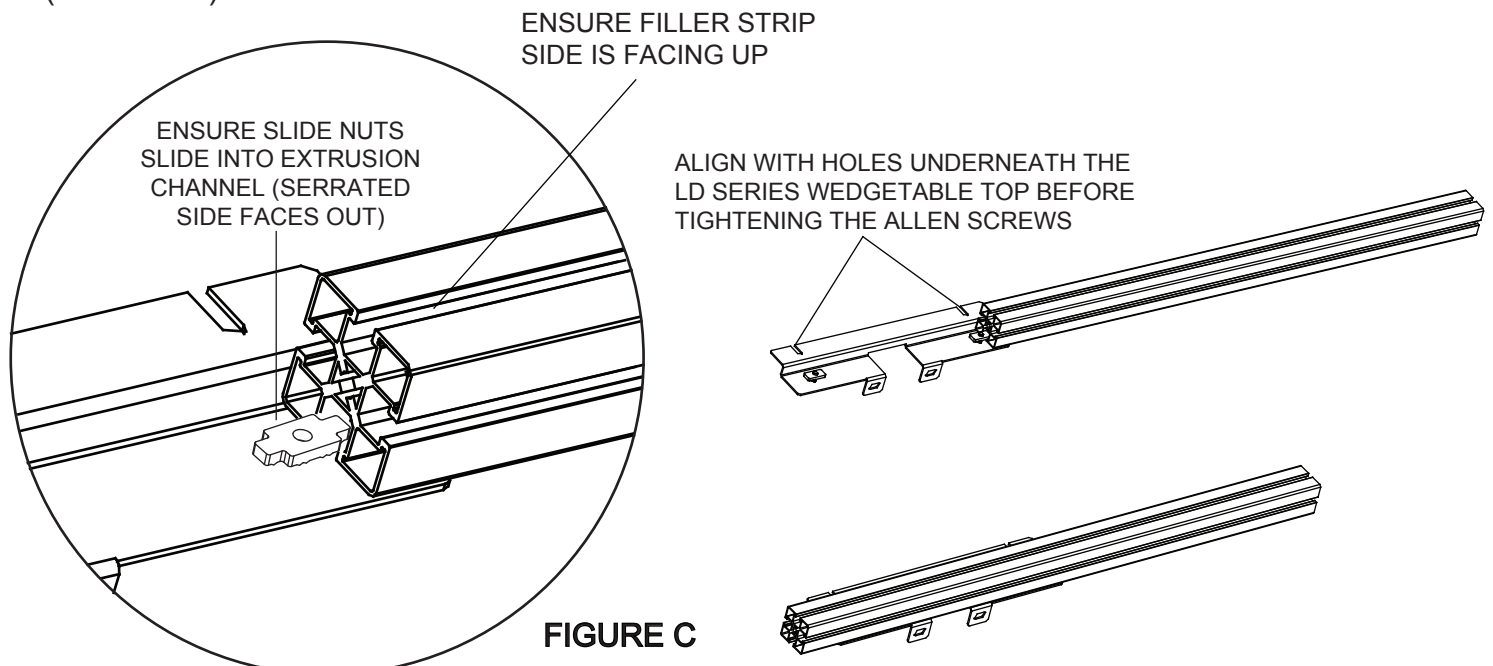


**FIGURE A**

- 2) Loosely install (2) rectangular nuts and (2) allen screws onto the LCD desk support bracket as shown. **(FIGURE B)**



- 3) Slide the extrusion onto the desk support bracket and tighten the allen screws as shown. **(FIGURE C)**



**FIGURE C**

## INSTALLATION (Continued)

- 4) Install the extrusion with assembled desk support bracket onto the LD Series Wedge tab and install (2) 1/4-20x5/8" allen screws as shown. (FIGURE D)

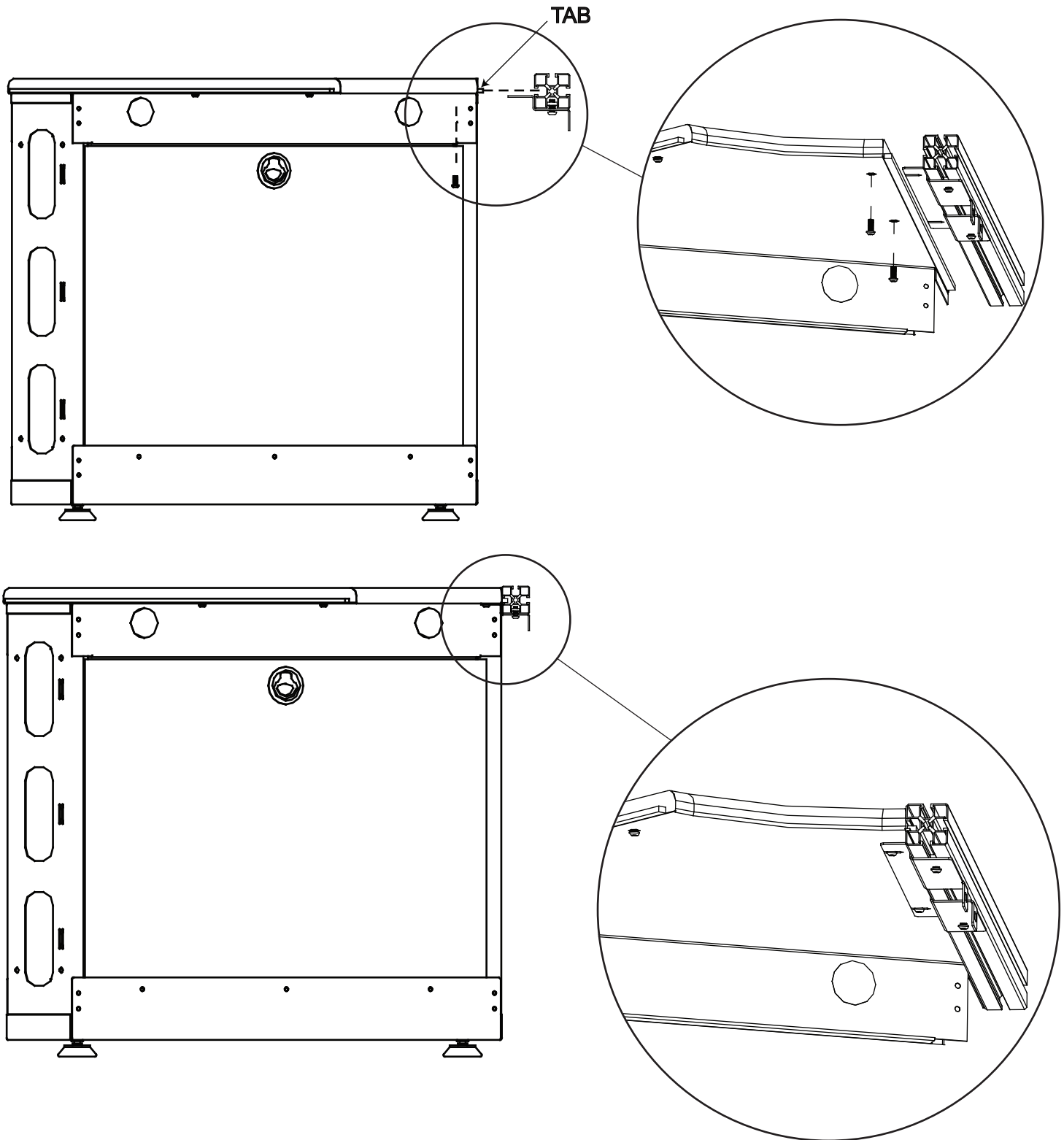
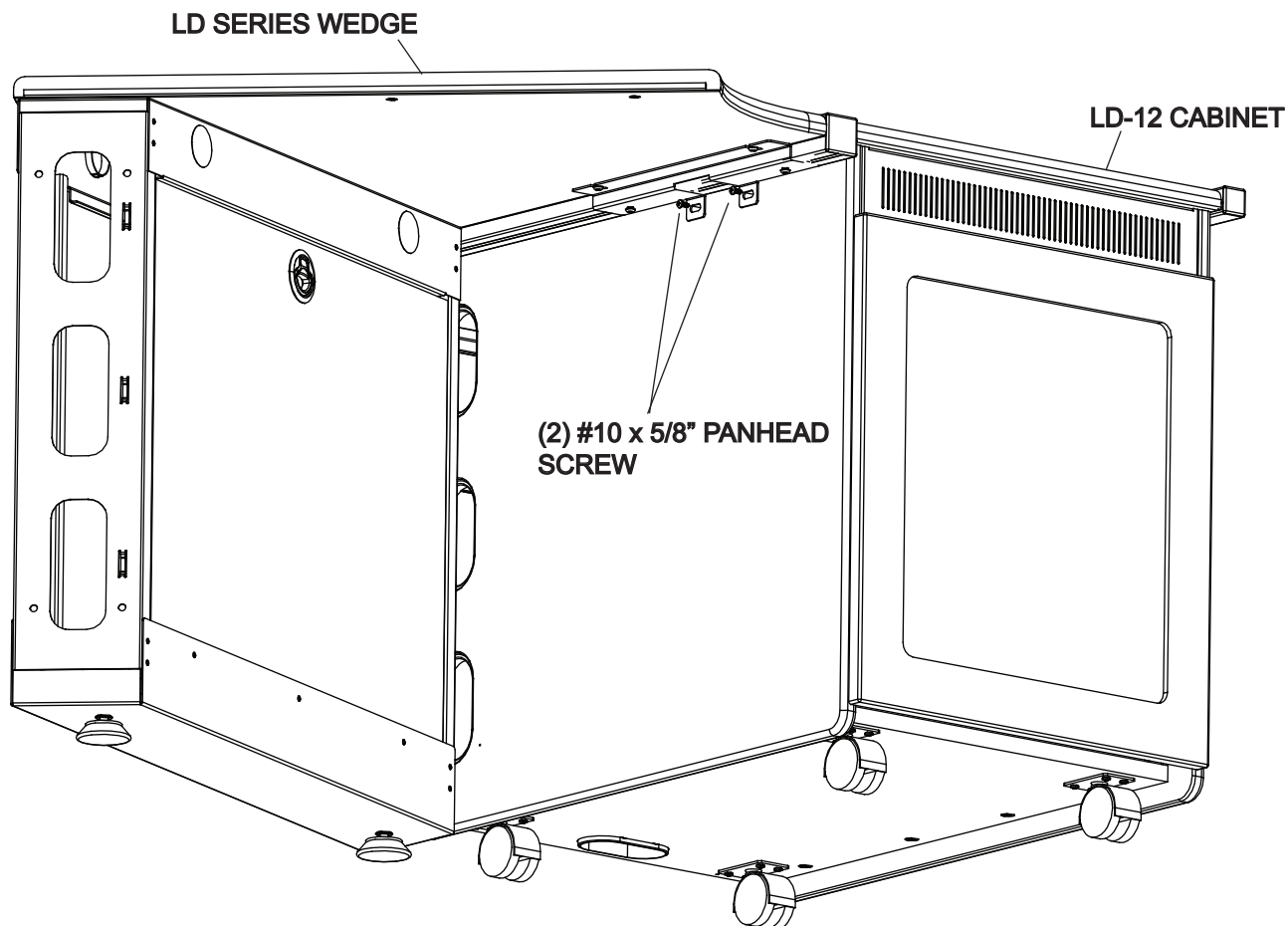


FIGURE D

## INSTALLATION (Continued)

- 5) Install the LD-12 cabinet tab into the extrusion channel and secure the LD-12 to the LD series wedge using (2) #10 x 5/8" panhead screws as shown. **(FIGURE E)**



**FIGURE E**

### **WARRANTY**

Middle Atlantic Products (the "Company") warrants the LD-WK LD to LCD Desk Wedge Joiner Kit to be free from defects in material or workmanship under normal use and conditions for a period of (7) years from the date of shipment by the company. The Company's entire liability to the purchaser, and the purchaser's (or any other party's) sole and exclusive remedy, under this warranty shall be limited, at the Company's option, to either (a) return of and refund of the price paid for, or (b) repair or replacement at the Company's factory of the products purchased, or any part or parts thereof, which the Company has determined to be defective after inspection thereof at the Company's factory.

This warranty does not cover damage due to acts of God, accident, misuse, abuse or negligence by parties other than the Company, or any modification or alteration of the products. In addition, this warranty does not cover damage due to improper handling, assembly, installation or maintenance.

THIS WARRANTY IS IN LIEU OF ALL OTHER WARRANTIES OF ANY KIND, EITHER EXPRESSED OR IMPLIED, INCLUDING, BUT NOT LIMITED TO, IMPLIED WARRANTIES OF MERCHANTABILITY AND FITNESS FOR A PARTICULAR PURPOSE.

TO THE MAXIMUM EXTENT PERMITTED BY APPLICABLE LAW, IN NO EVENT SHALL THE COMPANY BE LIABLE FOR ANY SPECIAL, INCIDENTAL, INDIRECT, OR CONSEQUENTIAL DAMAGES WHATSOEVER (INCLUDING, WITHOUT LIMITATION, DAMAGES FOR LOSS OF BUSINESS PROFITS, BUSINESS INTERRUPTION OR ANY OTHER PECUNIARY LOSS) ARISING OUT OF THE USE OF THE PRODUCTS PURCHASED, EVEN IF THE COMPANY HAS BEEN ADVISED OF THE POSSIBILITY OF SUCH DAMAGES. THE COMPANY'S LIABILITY TO THE PURCHASER (OR ANY OTHER PARTY) HEREUNDER, IF ANY, SHALL IN NO EVENT EXCEED THE PURCHASE PRICE OF THE PRODUCTS PAID TO THE COMPANY.

### **Corporate Headquarters**

Corporate Voice 973-839-1011 - Fax 973-839-1976  
International Voice +1 973-839-8821 - Fax +1 973-839-4982  
middleatlantic.com - info@middleatlantic.com

### **Middle Atlantic Canada**

Voice 613-836-2501 - Fax 613-836-2690  
middleatlantic.ca - customerservicecanada@middleatlantic.ca

### **Factory Distribution**

USA: NJ - CA - IL Canada: ON - BC

At Middle Atlantic Products we are always listening. Your comments are welcome. Middle Atlantic Products is an ISO 9001 and ISO 14001 Registered Company.



**30% Recycled Paper**