

NOTICE

THIS DRAWING EMBODIES A CONFIDENTIAL PROPRIETARY DESIGN ORIGINATED BY G. W. LISK COMPANY, INC. AND ALL DESIGN, MANUFACTURING, REPRODUCTION, USE, AND SALE RIGHTS REGARDING THE SAME ARE EXPRESSLY RESERVED. IT IS SUBMITTED UNDER A CONFIDENTIAL RELATIONSHIP FOR A SPECIFIC PURPOSE, AND THE RECIPIENT AGREES BY ACCEPTING THIS DRAWING NOT TO SUPPLY OR DISCLOSE ANY INFORMATION REGARDING IT TO ANY UNAUTHORIZED PERSON, OR TO INCORPORATE IN OTHER PROJECTS ANY SPECIAL FEATURES PECULIAR TO THIS DESIGN. ALL PATENT RIGHTS HERETO ARE EXPRESSLY RESERVED BY G. W. LISK COMPANY, INC., CLIFTON SPRINGS, NEW YORK.

REVISIONS

REV	DESCRIPTION	DATE	APPROVED
A	M22759/9-22-96 WAS M22759/7-22-96. REMOVED REF. P/N 24146. 30 APRIL 2003 MDD U	30 APR. 03	JCV
B	ADDED "STRIP AND TIN" REQUIREMENT. 2 IN. MIN. WAS 6 IN. MIN., 24-25 IN. WAS 23.750 - 25.750 IN. 10 MARCH 2004 MDD U	15 MAR. 04	GFH
C	34-35 IN. WAS 24-25 IN. 20 JUNE 06 AVB FINAL U NEXT HLA U PART NUMBER U	8 SEPT. 06	JCV
D	COLONIAL WIRE & CABLE ADDRESS WAS 100 CRAWFIELD ST. LEOMINSTER, MA 01453 27JAN10 AVB FINAL U NEXT HLA U PART NUMBER U	26JAN10	JCV
E	4.0 MIN. WAS 2.0 MIN. MDD 4AUG10 FINAL U NEXT HLA U PART NUMBER U	04AUG10	MTL
F	"IEWC GLOBAL SOLUTIONS" WAS "COLONIAL WIRE AND CABLE". MDD 15OCT10 FINAL U NEXT HLA U PART NUMBER U	15OCT10	MTL
G	REVISED NOTES ADDING "NOTE: DO NOT USE ADHESIVE TAPE TO BUNDLE ASSEMBLIES TOGETHER" J.WUNDER 16MAY17 3 P.A.D. U FINAL U NEXT HLA U PART NUMBER U	16MAY17	M.WARE

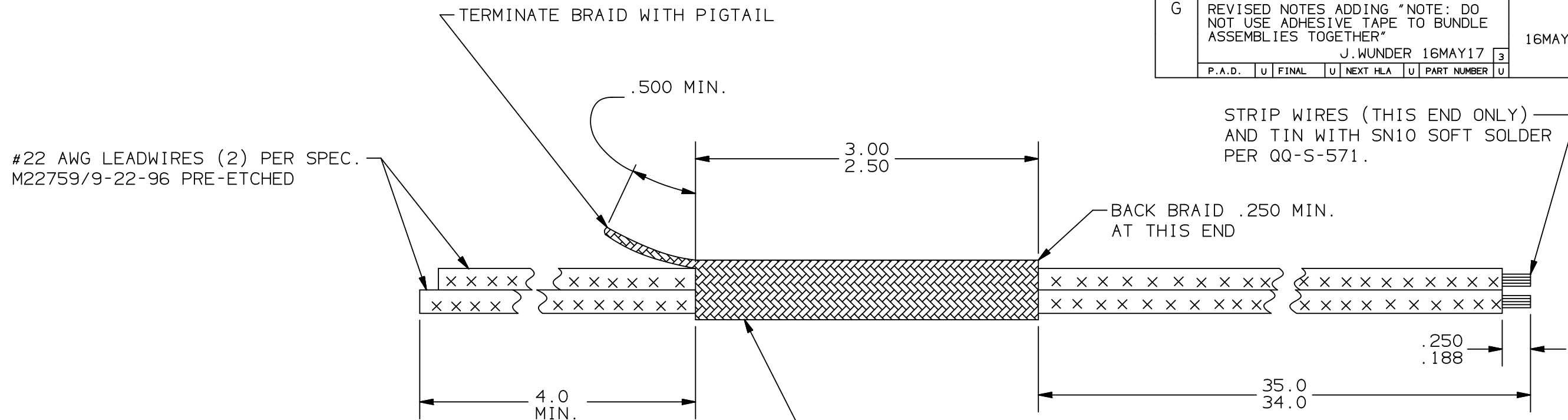

1. LEADWIRE TO BE SUPPLIED BY VENDOR.
2. BRAIDING DONE BY:
CO-OPERATIVE INDUSTRIES, INC (SPEC C1312)
100 OAKDALE ROAD
CHESTER, NEW JERSEY, 07930
OR
GLENAIR, INC.
1211 AIRWAY
GLENDALE CALIFORNIA, 91201-2497
OR
IEWV GLOBAL SOULTIONS
11B DANA HILL RD.
STERLING, MA 01564

NOTE: DO NOT USE ADHESIVE TAPE TO BUNDLE ASSEMBLIES TOGETHER.

CAGE CODE	MATERIAL SPECIFICATION	ITEM	PART NUMBER	DESCRIPTION	QTY
UNLESS OTHERWISE SPECIFIED	THIRD ANGLE PROJECTION	DRAWN	AVB 17 JAN. 2003	G. W. LISK CO. INC. CLIFTON SPRINGS, NEW YORK	
93 Ra FINISH ALL OVER		CHECK	JCV 17 JAN. 2003		
f - SMOOTH FINISH FOR APPEARANCE ONLY	MATERIAL	ENGINEER	JCV 17 JAN. 2003		
RUNOUT BETWEEN ALL DIAMETERS NOT TO EXCEED .005 FULL INDICATOR MOVEMENT	HEAT TREAT	NEXT ASSY	24397		
BREAK ALL SHARP EDGES - .010 MAXIMUM	FINISH	JOB NO.	L-6470	SIZE	B
† - RADIUS OR CHAMFER ACCEPTABLE				CAGE CODE	81983
				DWG NO	27737
				DO NOT SCALE	-
				WEIGHT	
				SHEET	
				REV	G