

GAFMIL™

Vehicle Wiring Harness Protection

The convoluted tubing GAFMIL™ is specifically designed to provide the protection benefits of a non slit-tube (full protection of the wire against dirt, abrasion, short bending radius and risk of wire exposure) with the ease of assembly of a slit tube.

- Reduction of assembly cycle time
- Weight reduction
- High mechanical protection of wires
- Tapeless solution
- Filling ratio up to 100%
- Easy to use
- Environmentally friendly solution



All our sites are ISO TS16949
and ISO 14001 certified

Applications & material

GAFMIL™ is a one piece slit closeable plastic convoluted tube made of two C shaped shells connected by a hinge, locking onto each other. The first convolute portion takes place on the wire harness, the second portion pivots thanks to the hinge and covers the first one. The overlap between the two convoluted portions avoids the risk of wire exposure, even in low radius curve zones. GAFMIL™ is available in various plastic grades of polypropylene which does not absorb moisture and provides excellent electrical insulation properties. It is also available in other plastic grades.

GAFMIL™ is compatible with Delfingen clips, fasteners and branching accessories.

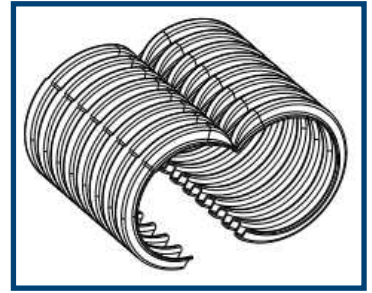

Characteristics

- **Colors:** black, orange, yellow and others upon request.

Physical characteristics	Specification	Unit	Flame retardant PP	High heat flame retardant PP	High heat PP
Mechanical					
Density	ISO 1183	g/cm ³	0.92	0.97	0.91
Tensile strength at break	ISO 527	MPa	34	32	34
Elongation a break	ISO 527	%	>500	>500	>500
Hardness	ISO 868	shore D	66	64	66
Thermal					
HDT (0.46/mm2)	ISO 75	°C	83	80	80
Vicat point A50 (10N)	ISO 306	°C	148	140	140
Flammability	FMVSS 302 D 45-1333	- -	Self Extinguishing type B	Self Extinguishing type B	< 100mm/min.
Temperature of use	continuous	°C	-40/100	-40/125	-40/125
Peak temperature	continuous	°C	125	150	150
Chemical resistance	Resist to automotive fluids such as fuels, oils, brake fluids, windshield washer fluid, acid ...				

Dimensions

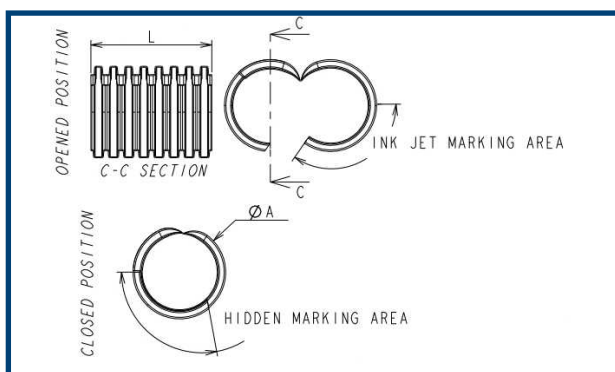

Designation	Ø Int (mm)	Ø Ext (mm)
GAFMIL™ Ø11*	12,3	16,6 ± 0,5
GAFMIL™ Ø13	14,0	18,5 ± 0,5
GAFMIL™ Ø16	16,5	21,0 ± 0,5
GAFMIL™ Ø19	19,0	24,4 ± 0,5
GAFMIL™ Ø23	22,5	28,5 ± 0,5
GAFMIL™ Ø26	25,5	31,9 ± 0,5
GAFMIL™ Ø29*	29,3	35,9 ± 0,5
GAFMIL™ Ø32*	32,0	39,4 ± 0,5

*upon request

Specification

GAFMIL™ is approved by PSA STE 96 458 709 99 ind C (PPME), Ford ES-XU5T-14A099-AA/E (PPAE/PPME) and Delphi M5912 (HHPP). It meets also the requirements of Renault 36-05-035 ind OR (PPME).

Packaging

GAFMIL™ is delivered in cut pieces or in bulk (in closed position). Cardboard boxes or gaylords, or returnable packaging.

Data & photos for information only, subject to modifications without notice

Headquarters:

Delfingen Industry S.A.
25340 Anteuil - FRANCE
Tel: +33 (0)3 81 90 73 00
Fax: +33 (0)3 81 90 73 19

Europe, Africa & South America:

Delfingen FR-Roissy
4 Place de Londres,
Bât. Saturne BP 13716
95726 Paris Roissy CDG - FRANCE
Tel: +33 (0)1 41 84 31 00

North & Central America:

Delfingen US, Inc.
840 West Long Lake Road
Suite 120
Troy, MI 48098 - USA
Tel: +1 248 519 0534

Asia - Pacific:

Delfingen Asia Pacific
23F Cifigroup tower
33 Huayuanshiqiao Road, Pudong District
200120 Shanghai - CHINA
Tel: +86 21 6101 0451