

AS85049/41 and MS3057A Strain Reliefs



Strain
Reliefs

MIL-DTL-5015
MS "V" Thread
(Mates to General
Duty 'A' Endbell)

M85049/41-3A
Basic Part No. _____ Dash No. _____

SUPERCEDED SPECIFICATION

MS3057-16A
Basic Part No. _____ Dash No. _____

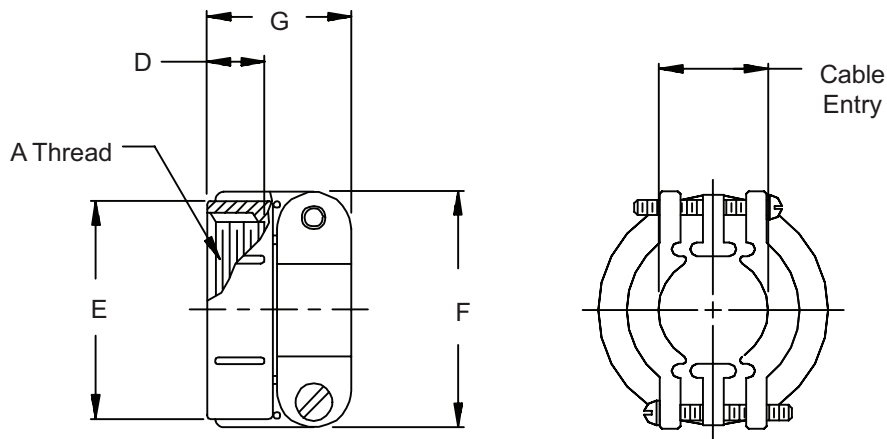

TABLE I

Dash No.	Conn. Shell Ref.(s)	A Thread Class 2B	Cable Entry Max	D Ref.	E Dia ±.031 (0.8)	F ±.031 (0.8)	G ±.031 (0.8)
3A	8S, 10S	1/2 - 28 UNEF	.250 (6.4)	.406 (10.3)	.688 (17.5)	.812 (20.6)	.812 (20.6)
4A	10SL, 12S, 12	5/8 - 24 UNEF	.312 (7.9)	.406 (10.3)	.812 (20.6)	.875 (22.2)	.812 (20.6)
6A	14S, 14	3/4 - 20 UNEF	.438 (11.1)	.406 (10.3)	.969 (24.6)	1.062 (27.0)	.875 (22.2)
8A	16S, 16	7/8 - 20 UNEF	.562 (14.3)	.406 (10.3)	1.094 (27.8)	1.156 (29.4)	.938 (23.8)
10A	18	1 - 20 UNEF	.625 (15.9)	.406 (10.3)	1.188 (30.2)	1.250 (31.8)	.938 (23.8)
12A	20, 22	1 3/16 - 18 UNEF	.750 (19.1)	.406 (10.3)	1.375 (34.9)	1.469 (37.3)	.938 (23.8)
16A	24, 28	1 7/16 - 18 UNEF	.938 (23.8)	.406 (10.3)	1.656 (42.1)	1.688 (42.9)	1.031 (26.2)
20A	32	1 3/4 - 18 UNS	1.250 (31.8)	.469 (11.9)	2.031 (51.6)	2.031 (51.6)	1.094 (27.8)
24A	36	2 - 18 UNS	1.375 (34.9)	.531 (13.5)	2.219 (56.4)	2.281 (57.9)	1.156 (29.4)
28A	40	2 1/4 - 16 UN	1.625 (41.3)	.531 (13.5)	2.500 (63.5)	2.688 (68.3)	1.688 (42.9)
32A	44	2 1/2 - 16 UN	1.875 (47.6)	.594 (15.1)	2.781 (70.6)	2.938 (74.6)	1.750 (44.5)
40A	48	3 - 16 UN	2.375 (60.3)	.656 (16.7)	3.281 (83.3)	3.500 (88.9)	1.750 (44.5)

1. For complete dimensions see applicable Military Specification.
2. Metric dimensions (mm) are indicated in parentheses.
3. Cable Entry is defined as the accomodation entry for the wire bundle or cable. Dimensions are not intended for inspection criteria.
4. Finish on M85049/41 is cadmium olive drab over electroless nickel (1,000 hour salt spray).