

## Analog Audio Embedder / De-embedder

- Simultaneous embedding and de-embedding
- SDI video formats up to 3Gbit (1080p60)
- 4 x Analog audio inputs and outputs
- Selectable full scale audio level or line level I/O
- Selectable audio groups
- Optional Fiber I/O
- Bidirectional audio transport over fiber
- Integrated test tone generator
- Auto black if no video present
- Selectable SDTV 24 bit mode
- Video present and audio status LEDs



The PDM 1383 is a versatile analog audio embedder and de-embedder designed for a wide range of SDI video formats up to 3Gbit. Analog audio I/O is available on a 25 pin SubD connector.

Select the audio group and analog full scale level (or line level) using the rotary switches. Additional channels of audio can be embedded and de-embedded by cascading modules together. Simultaneous embedding and de-embedding means the module can de-embed and output the audio from the selected audio group before overwriting with the new audio input.

Optional fiber I/O SFP modules adds fiber connectivity for embedding and de-embedding directly from the fiber I/O.

The selectable "auto black" mode uses a black video frame (in the last detected video standard) if no SDI input is present. This allows the module to embed audio even when no video source is available. This mode is useful if the application is only transporting audio between locations either electrically or over fiber. The module also includes a special mode of operation which allows the bidirectional transport of audio (only) using two modules.

The selectable 1 kHz test tone generator is integrated for audio testing purposes. The module includes an LED for video present indication as well as two multi color audio status LEDs.

### Fiber I/O Options

Inserts into the Fiber SFP cage on the side of the module. Please select option from below:

#### Tranceiver ( Receive and Transmit )

Wavelength	TX Power	RX Sensitivity	Max Distance	Option #
1310nm	-5dBm	-19dBm	10km (6.2miles)	<b>OH-TR-1</b>
1550nm	-1dBm	-19dBm	40km (24.8miles)	<b>OH-TR-3-1550</b>

#### Transmitter only

Wavelength	TX Power	Max Distance	Option #
1310nm	-5dBm	10km (6.2miles)	<b>OH-TX-1</b>

#### Receiver only

Wavelength	RX Sensitivity	Option #
1270-1630nm	-19dBm	<b>OH-RX-1</b>



## Technical Specifications

<b>SDI Input</b>	1 x SDI video on 75 Ohm BNC connector SMPT 424M, SMPT 292M, SMPT 259M Multi-standard operation from 270Mbit/s to 3Gbit/s SDTV (525/625) 720p and 1080p (23.98/24/25/29.97/30/50/59.94/60 Hz) 1080psf (23.98/24/25/29.97/30 Hz) 1080i (50/59.94/60 Hz) Return Loss: > 15dB to 1.5Gbit/s and > 10dB up to 3Gbit/s Automatic cable EQ (Belden 1694A cable) 250m @ 270Mbit/s, 140m @ 1.5Gbit/s, 80m @ 3Gbit/s
<b>Optical I/O (Option)</b>	1 x fiber optical input and/or output LC singlemode fiber connection (see table) SMPT 297M - 2006
<b>SDI Output</b>	1 x SDI video on 75 Ohm BNC connector SMPT 424M, SMPT 292M, SMPT 259M Multi-standard operation from 270Mbit/s to 3Gbit/s
<b>Audio Inputs</b>	4 x analog audio inputs on 25 pin SubD Connector (10K Ohm) Full scale analog audio level (or line level) selectable via rotary switch AES group selection provided via rotary switch
<b>Audio Outputs</b>	4 x analog audio outputs on 25 pin SubD Connector (150 Ohm) Full scale analog audio level (or line level) selectable via rotary switch AES group selection provided via rotary switch
<b>Power</b>	+12VDC power supply (included)
<b>Size</b>	105mm x 95mm x 22mm (4.13" x 3.74" x 0.86")
<b>Model #</b>	PDM 1383
<b>Includes</b>	Module, power supply, SubD screw terminal adapter PCB, plastic transport case

## Power Adapter Options

The module **INCLUDES** an AC power supply. the power adapters below are optional.



**P-TAP 1000**  
Use with a standard battery P-TAP power source.



**XLR 1000**  
Use with a standard 4 pin XLR camera battery power source.

Specifications subject to change

## PDM 1383 Applications

The basic SDI embedding and de-embedding applications for the PDM 1383 are somewhat obvious, but with the “auto-black” mode the modules can be used to transport audio signals only. This provides a very cost effective way to transport multi-channel audio over fiber (or coax) without the need for dedicated audio A/D converters and external optical multiplexing. This when combined with the new “Bidirectional Master” functionality really expands the flexibility of the modules into dedicated audio applications.

Below are two examples of how the modules can be utilised for “audio only” transport over fiber.

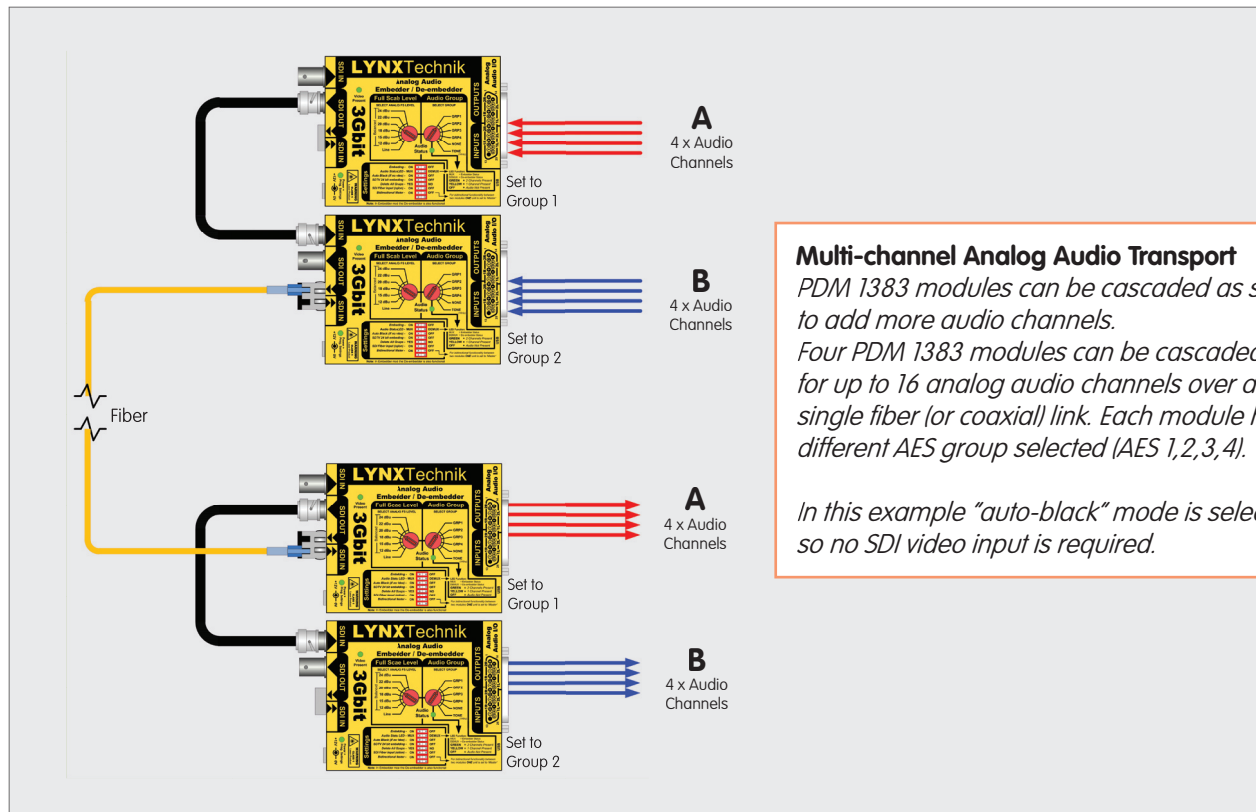

### Multi-channel Analog Audio Transport

*PDM 1383 modules can be cascaded as shown to add more audio channels.*

*Four PDM 1383 modules can be cascaded for up to 16 analog audio channels over a single fiber (or coaxial) link. Each module has a different AES group selected (AES 1,2,3,4).*

*In this example “auto-black” mode is selected, so no SDI video input is required.*

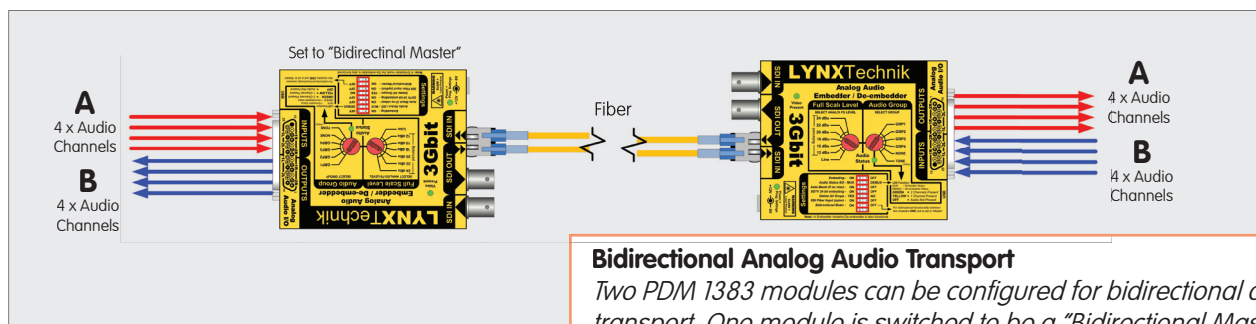

### Bidirectional Analog Audio Transport

*Two PDM 1383 modules can be configured for bidirectional audio transport. One module is switched to be a “Bidirectional Master”*

*This works for audio signals only, and “auto-black” mode is used.*

*(Note: Cascading modules is not possible in bidirectional mode)*