

INSTRUCTION SHEET
RIB SERIES
RISER BASE SYSTEM

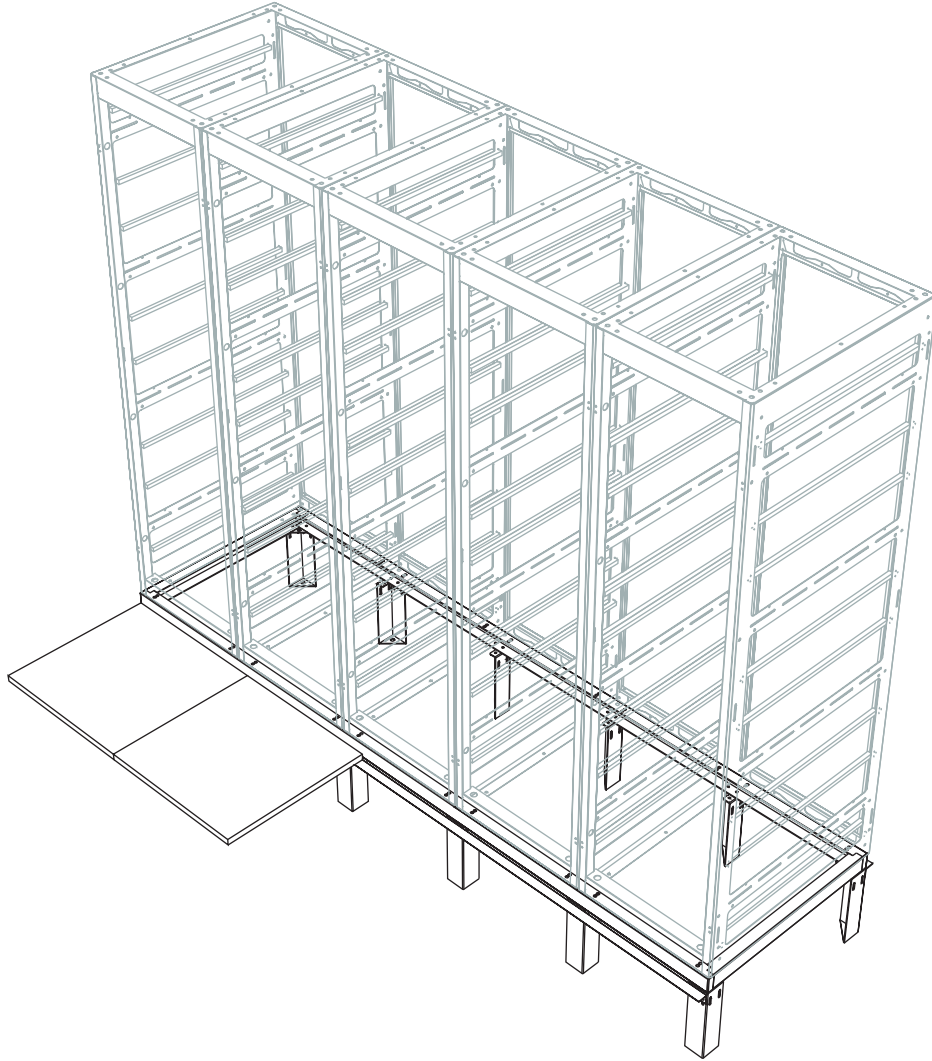

THANK YOU

Thank you for purchasing the RIB Series Riser Base System. Please read these instructions thoroughly before installing / assembling this product.

PRODUCT FEATURES

- Simplifies raised floor installation while providing access to the plenum below
- Allows pre-wiring and enclosure installation before installing the raised floor
- Riser base features knockouts for passing cables between joined riser bases

ASSEMBLY

NOTE: When using DRK Series enclosures, remove the leveling feet before RIB installation.

NOTE: Skip to step 4 on page 2 when mounting the RIB without the VFEET and ANGLE.

- 1) Bolt the VFEET to the RIB using the supplied hardware.
- 2) Mount the VFEET to the floor:
Using the appropriate customer supplied hardware anchor VFEET/
RIB assembly to the floor.
- 3) Mount the ANGLE to the VFEET:
Using the supplied hardware bolt the ANGLE
to the VFEET, ensure the angle is level and
at the required height to support the raised
floor tiles.

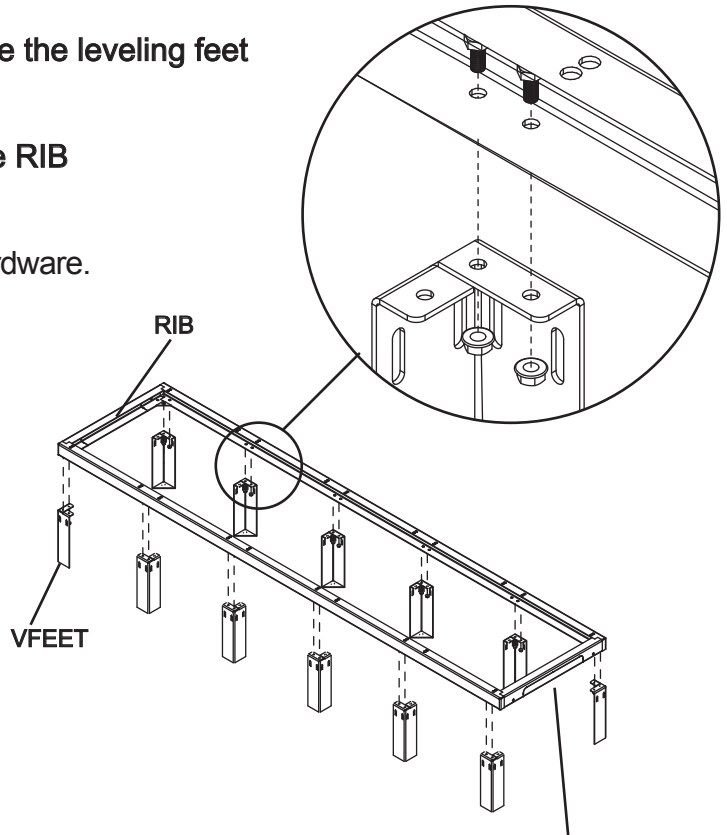

NOTE: To remove the knockout, forcefully hit it with a metal hammer. Clean the edge with a screwdriver to avoid wire chafing.

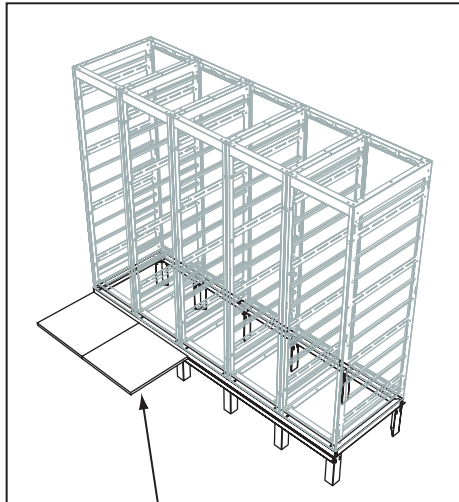

**ANGLE supports
raised floor tiles**

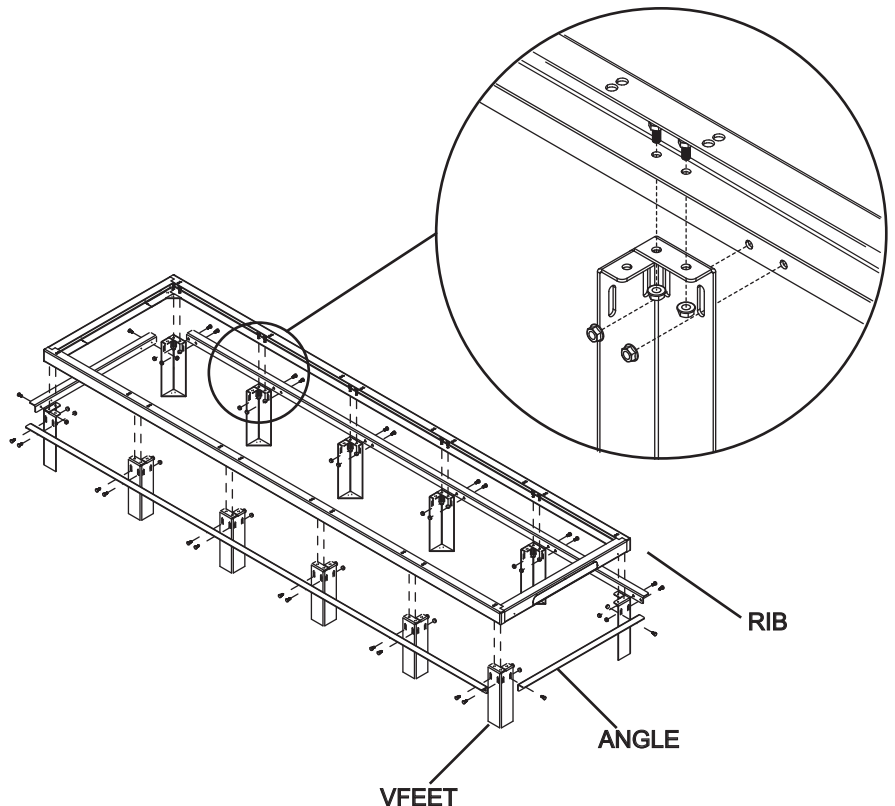

- 4) Mount the rack to the RIB:
Using the supplied hardware bolt the rack to the RIB.
Gang all of the racks mounted to the RIB using the following:

Appropriate Ganging Hardware for Racks:

GANG-10 (All Racks)

GANG-10T (BGR Racks Only)

BOND-G24 (Used for Electrical Bonding of racks)

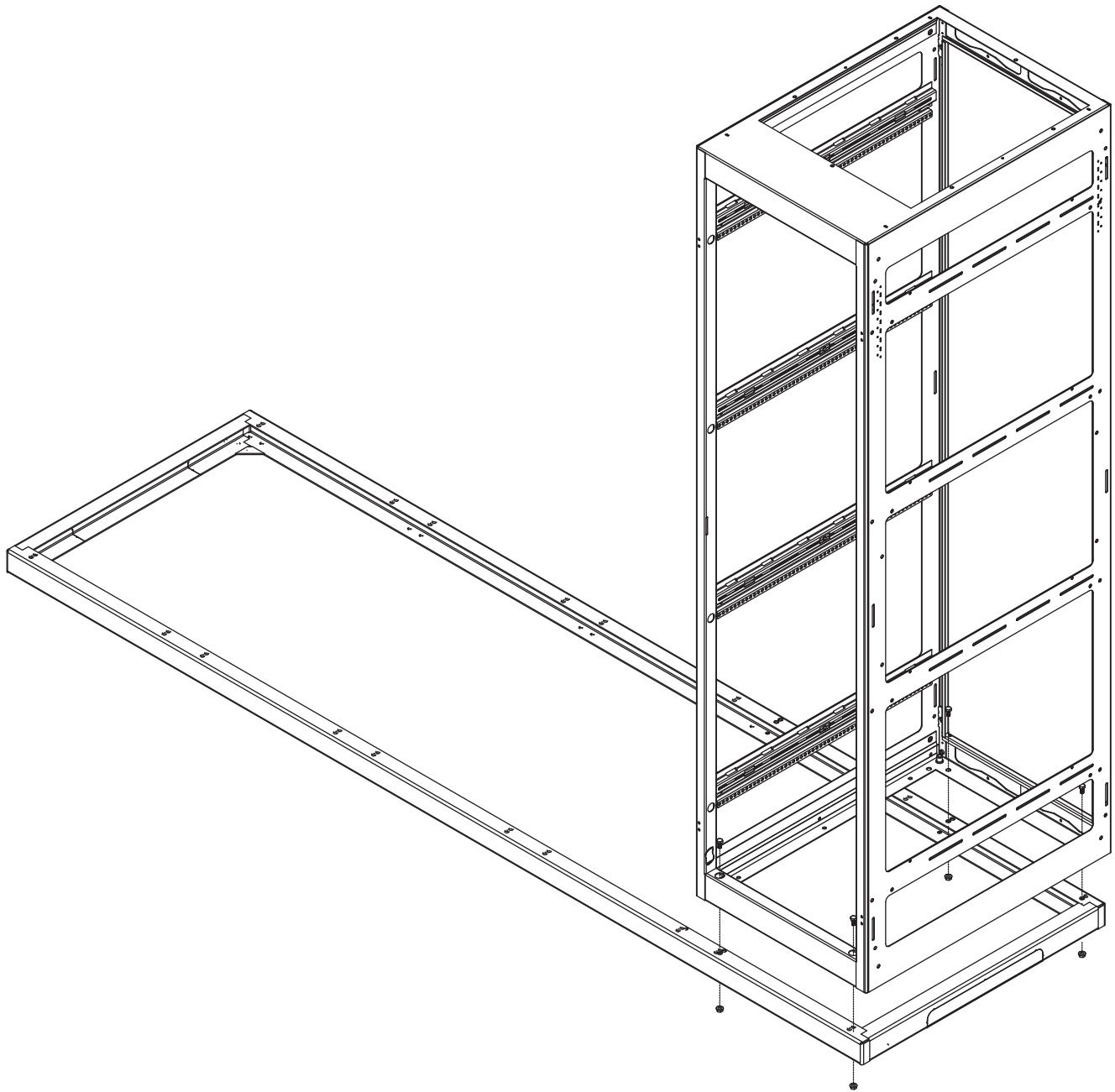

WARRANTY

Middle Atlantic Products, Inc. (the "Company") warrants the RIB Series Riser Base to be free defects in material or workmanship under normal use and conditions for a period of (3) three years from date of shipment by the Company.

The Company's entire liability to the purchaser, and the purchaser's (or any other party's) sole and exclusive remedy, under this warranty shall be limited, at the Company's option, to either (a) return of and refund of the price paid for, or (b) repair or replacement at the Company's factory of the products purchased, or any part or parts thereof, which the Company has determined to be defective after inspection thereof at the Company's factory.

This warranty does not cover damage due to acts of God, accident, misuse, abuse or negligence by parties other than the Company, or any modification or alteration of the products. In addition, this warranty does not cover damage due to improper handling, assembly, installation or maintenance.

THIS WARRANTY IS IN LIEU OF ALL OTHER WARRANTIES OF ANY KIND, EITHER EXPRESSED OR IMPLIED, INCLUDING, BUT NOT LIMITED TO, IMPLIED WARRANTIES OF MERCHANTABILITY AND FITNESS FOR A PARTICULAR PURPOSE.

TO THE MAXIMUM EXTENT PERMITTED BY APPLICABLE LAW, IN NO EVENT SHALL THE COMPANY BE LIABLE FOR ANY SPECIAL, INCIDENTAL, INDIRECT, OR CONSEQUENTIAL DAMAGES WHATSOEVER (INCLUDING, WITHOUT LIMITATION, DAMAGES FOR LOSS OF BUSINESS PROFITS, BUSINESS INTERRUPTION OR ANY OTHER PECUNIARY LOSS) ARISING OUT OF THE USE OF THE PRODUCTS PURCHASED, EVEN IF THE COMPANY HAS BEEN ADVISED OF THE POSSIBILITY OF SUCH DAMAGES. THE COMPANY'S LIABILITY TO THE PURCHASER (OR ANY OTHER PARTY) HEREUNDER, IF ANY, SHALL IN NO EVENT EXCEED THE PURCHASE PRICE OF THE PRODUCTS PAID TO THE COMPANY.

Corporate Headquarters

Corporate Voice 973-839-1011 - Fax 973-839-1976
International Voice +1 973-839-8821 - Fax +1 973-839-4982
middleatlantic.com - info@middleatlantic.com

Middle Atlantic Canada

Voice 613-836-2501 - Fax 613-836-2690
middleatlantic.ca - customerservicecanada@middleatlantic.ca

Factory Distribution

USA: NJ - CA - IL Canada: ON - BC

At Middle Atlantic Products we are always listening. Your comments are welcome.

Middle Atlantic Products is an ISO 9001 and ISO 14001 Registered Company.

