

Revision level		Revision Record	Changed	Date	Approved	Date
part	drawing					
—	02	See ECN 011621	A.A.C.	09/01/10	K.A.C.	09/01/10

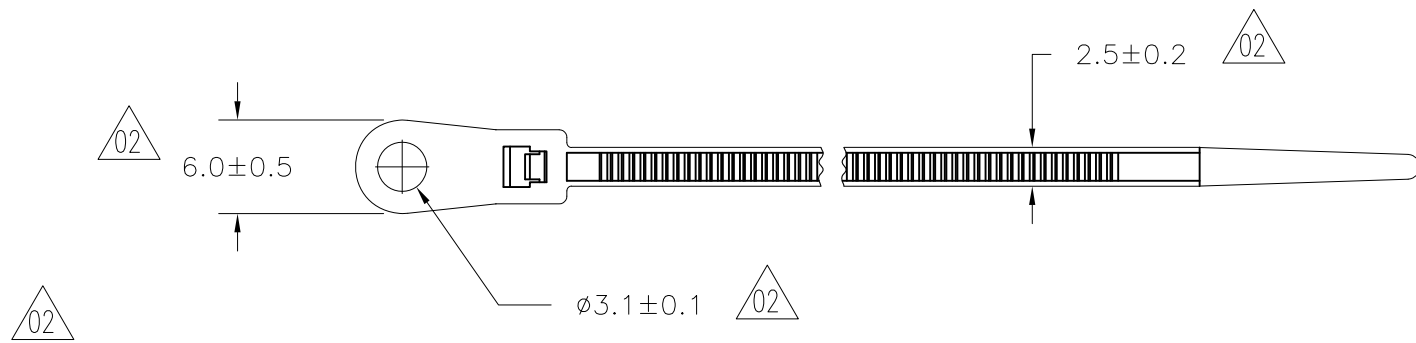
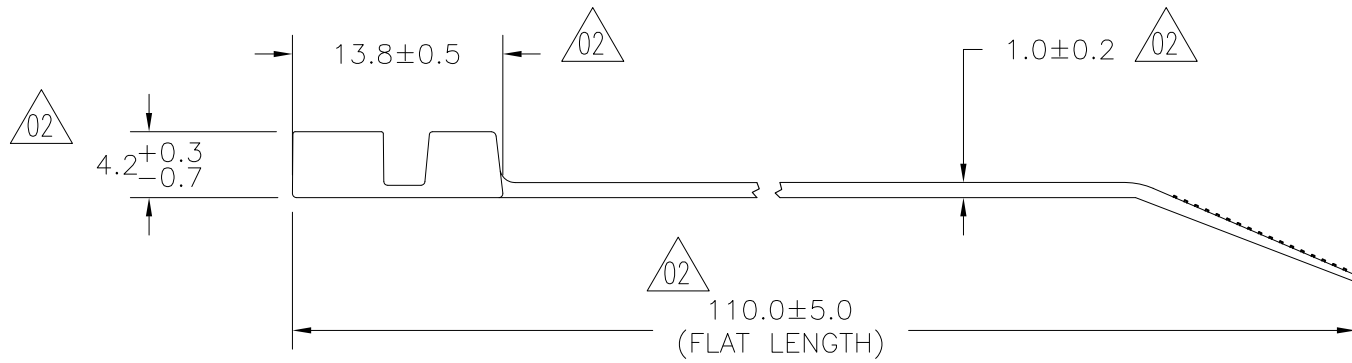

80
Min Loop Tensile Strength(N)
1.5 to 20
Bundle Range
PA66
Material
Dimension tolerances unless otherwise specified .XXX = $\pm .0130$ .XXX = $\pm .130$ .XX = $\pm .30$ .X = $\pm$ NOTED $\angle = \pm 0.5^\circ$
Dimension Units mm
PERFORMANCE SPECIFICATION

ACAD MECH 2009

ALL PROPRIETARY RIGHTS IN THE SUBJECT MATTER SHOWN ON THIS DRAWING ARE EXCLUSIVE PROPERTY OF HELLERMANN TYTON

Drawn G.G.G. 10/06/91  
Approved K.A.C. 09/01/10

**HellermannTyton**

7930 N. Faulkner Rd.  
Milwaukee, WI 53224  
Ph: (414) 355-1130  
Fx: (414) 362-8342

Scale 1:2  
Computer File Number CT\CST\2018005\_02

Title **T18MR SCREW MOUNT TIE**

Drawing-No **CT2018005CST**

Format AH  
Sheet 1 of 1