

3" FIBER CORE

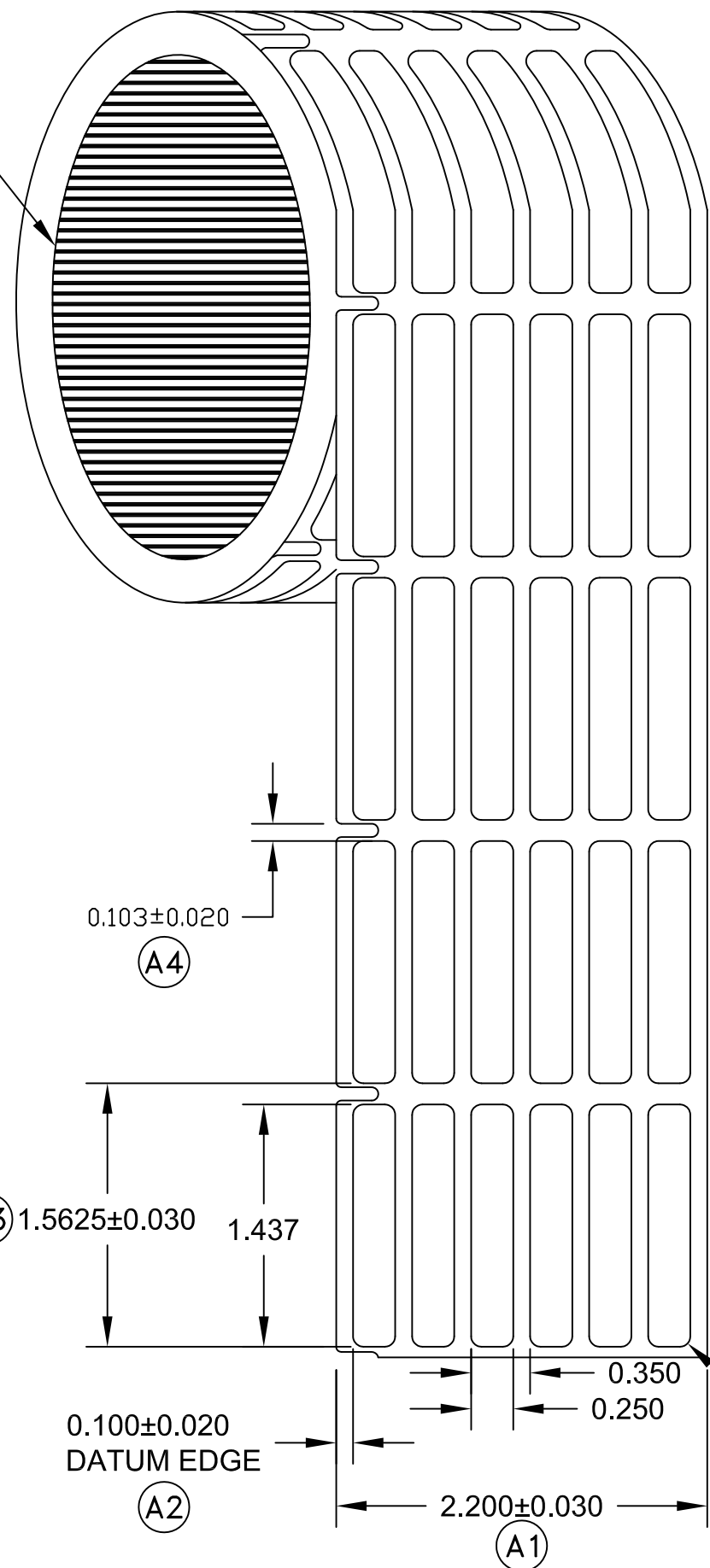
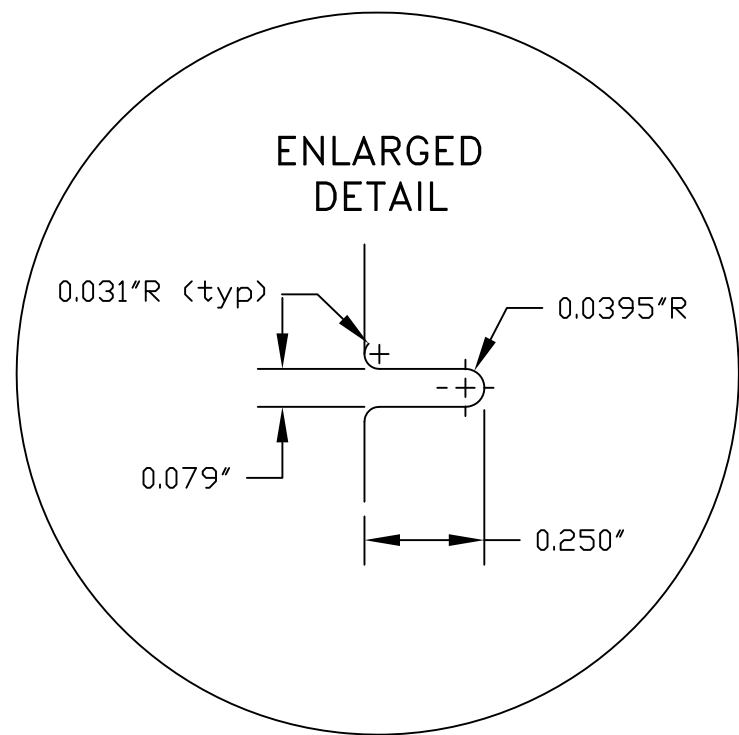

BRADY PART NUMBER	Y4130729	BRADY CORP.
MATERIAL	B-498	DATE
		03-02-15
BACKGROUND COLOR	WHITE	
PRINT COLOR	UNPRINTED	
PRINT COLOR	---	
PRINT COLOR	---	
SUB-SURFACE PRINT?	NO	
STANDARDS: Label Size Dim. ±0.010 Non-Label Size Dim. ±0.030		
ALL DIMENSIONS IN INCHES UNLESS SPECIFIED		
CUSTOMER NAME	IEWC CORP.	
CUSTOMER PART NUMBER	---	
CUSTOMER REV	---	
CUSTOMER DWG ON FILE?	NO	
DRAWING BY	OER	
ACAD FILE	15Y4130729R	
● BRADY CORP INTERNAL REVISIONS ●		
DATE	NAME	DESCRIPTION
08/20/15	BJK	ADDED NOTCH PER ECN

Material Approval and Parameter Sheet (MAP)

Mapping the way to customer satisfaction.

Y4130729

UOM: Piece

Created on 03/02/15

Created by: OER

Production Quality Checks

Quality Checks	Code	Operation		_____										
		Low	High	1	2	3	4	5	6	7	8	9	10	
Scoring/slitting width	A1	2.17	2.23	_____	_____	_____	_____	_____	_____	_____	_____	_____	_____	_____
Label edge to liner edge	A2	0.08	0.12	_____	_____	_____	_____	_____	_____	_____	_____	_____	_____	_____
Vertical repeat	A3	1.53	1.59	_____	_____	_____	_____	_____	_____	_____	_____	_____	_____	_____
Top of notch to top of label	A4	0.08	0.12	_____	_____	_____	_____	_____	_____	_____	_____	_____	_____	_____
				Initials	_____	_____	_____	_____	_____	_____	_____	_____	_____	_____
				Date	_____	_____	_____	_____	_____	_____	_____	_____	_____	_____

Packaging Requirements

Specified By	Pkg Qty	Pkg UOM	Other Specifics	Special Requirements
Brady - MAX 7.90" diam	13,200	pcs/roll	max 2 splices/roll	Apply SEL Label, Standard Tab, Scan Work Order
IEWC Corp.	5,000	pcs/roll	max 2 splices/roll	Apply SEL Label, Standard Tab, Scan Work Order

Product Requirements

Packaging Documentation

Core type: _____ Pcs/roll: _____
Core size: _____ Qty/pkg: _____
Revolutions: _____ Pkg/box: _____

Revisions

Date	Initials	Changes
08/20/15	BJK	NOTCH DIMENSION INSPECTION ADDED PER ECN